

**Shawna Papale**

---

**From:** Patrick Donnelly <pdonnelly@bdflegal.com>  
**Sent:** Wednesday, February 23, 2022 7:13 AM  
**To:** Shawna Papale; Info  
**Cc:** PGoldman@goldmanpllc.com; Michael Fogel  
**Subject:** Letters to OCIDA objecting to taking 411 Columbia Street by eminent domain  
**Attachments:** 2022-02-22 O'Brien letter to OCIDA.PDF; 2022-02-22 Final BDF letter to OCIDA w exhibits A-D.pdf

Dear Oneida County Industrial Development Agency:

Please see the attached letter from this firm and the attached letter from James P. O'Brien III objecting to taking by eminent domain the property at 411 Columbia Street, Utica, NY for the Central Utica Building, LLC ("CUB") project. Please include the attached in the record of the public hearing scheduled for February 23, 2022.

Thank you,

*Patrick D. Donnelly, Esq.*  
BROWN DUKE & FOGEL, P.C.  
120 Madison Street, AXA Tower 2, Suite 1620  
Syracuse, New York 13202  
Phone: (315) 399-4343, x206  
Fax: (315) 472-6215  
[pdonnelly@bdflegal.com](mailto:pdonnelly@bdflegal.com)  
<http://bdflegal.com/>

\*\*\*\*\*  
**Confidentiality Notice:** This e-mail transmission (including any attachments) is intended only for the use of the individual or entity to which it is addressed, and may contain information that is privileged, confidential, and exempt from disclosure under applicable law. If you are not the intended recipient, you are hereby notified that any disclosure, copying, distribution, or the taking of any action in reliance on the contents of this e-mail or any attachment is strictly prohibited. If you have received this transmission in error, please immediately notify the sender by return e-mail and delete all copies of this e-mail and any attachments.  
\*\*\*\*\*

CAUTION: This email originated from outside of the organization. Do not click links or open attachments unless you recognize the sender and know the content is safe.

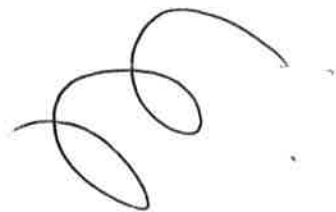

# BROWN DUKE & FOGEL, P.C.

ATTORNEYS AND COUNSELORS AT LAW

WWW.BDFLEGAL.COM

Michael A. Fogel, Esq.  
Brown Duke & Fogel, P.C.  
120 Madison Street, Suite 1620  
Syracuse, New York 13202  
[mfogel@bdflegal.com](mailto:mfogel@bdflegal.com)  
Tel: 315-399-4343

March 2, 2022

Executive Director Shawna Papale  
Oneida County Industrial Development Agency  
Attn: Chairman  
584 Phoenix Drive  
Rome, New York 13441  
[info@mvedge.org](mailto:info@mvedge.org)  
[spapale@mvedge.org](mailto:spapale@mvedge.org)

**Re: OCIDA Eminent Domain Procedure Law (“EDPL”) Article 2 Public Hearing  
Taking for Central Utica Building, LLC (“CUB”)  
February 23, 2022 at 9:00 a.m.; written comments on or before March 2, 2022**

Dear Executive Director Papale and Oneida County Industrial Development Agency:

This office represents Bowers Development, LLC and Utica Med Building, LLC (collectively “Bowers”). Please accept this letter as Bowers’ further objections and comments as to the February 23, 2022 Eminent Domain Procedure Law (“EDPL”), Article 2, Public Hearing (“Public Hearing”) by the Oneida County Industrial Development Agency (“OCIDA”) regarding its proposed taking by eminent domain of the property referred to as 411 Columbia Street, Utica, New York (SBL No.: 318.41-2-38) (the “Property”) for the proposed Central Utica Building, LLC (“CUB”) Project (the “CUB Project”). As stated in OCIDA’s public hearing notice, written comments will be accepted through the close of business on March 2, 2022.

As discussed in our prior letter dated February 22, 2022, it would be outrageous, unlawful, unconstitutional and an abuse of discretion for OCIDA to take the Property by eminent domain as requested by CUB. This letter supplements and is in addition to our prior letter and our comments offered at the February 23<sup>rd</sup> Public Hearing.

First and foremost, as discussed below, due to OCIDA’s delay in responding to our Freedom of Information Law (“FOIL”) requests and unexplained refusal to allow us to review the documents referred to in the public notice for the eminent domain proceeding, OCIDA should extend the public comment period until those documents are provided for us to review and comment on.

OCIDA has still not responded to FOIL requests by us on behalf of Bowers for information relevant to the CUB Project. Enclosed as Exhibit A is our FOIL request dated December 13, 2021 and the response to same dated January 13, 2022. While OCIDA did respond to our FOIL request on January 13, 2022, it was incomplete which necessitated, in part, our submission of a subsequent FOIL request on January 21, 2022. Enclosed as Exhibit B is our FOIL request dated January 21, 2022. Enclosed as

states among other things that there should be a better strategy to give notice of such public hearings with clarity and overall openness.

Furthermore, it appears that OCIDA is taking the Property by eminent domain for and delegated eminent domain powers to a nonprofit entity or an entity such as Mohawk Valley Health System ("MVHS") for the purposes proposed by CUB and MVHS. OCIDA is not allowed to do this under the EDPL and Article 18-A of the General Municipal Law (GML). This exceeds the powers granted to OCIDA, including under GML § 858. See also GML § 854(13).

There also appear to be a number of errors, misrepresentations or falsehoods in the application and submissions by CUB and MVHS to OCIDA which form the purported basis for this eminent domain proceeding (*see, e.g.*, Exhibit A). For example, the application to OCIDA by CUB, on page 7, in response to the questions "How will the Applicant's plans be affected or scaled back if Agency approval is not granted?", states: "It is likely that the MOB would not be built in a location in downtown Utica adjacent to the Wynn Hospital, a location preferred by the Wynn Hospital, the MOB's proposed tenants and the patient populations of both." This statement does not seem credible given the statements made at the Public Hearing and to OCIDA, including by CUB and MVHS representatives. It seems more than likely that CUB and MVHS want the MOB by the Wynn Hospital, that it would be built there and that it would not be built anywhere else, regardless of assistance from OCIDA. It also appears that all or parts of the CUB Project have been referred to as a "retail facility", which is clearly incorrect, and in any case, the CUB Project does not meet the criteria for assistance as a retail facility or project, and CUB has not shown that it meets these criteria (*see, e.g.*, the policy documents and other documents in Exhibit A, including the requirements as to blight; *see also* the provisions of GML § 862). The foregoing also raises issues of violations of the anti-pirating provisions of GML § 862 and whether the actions of OCIDA will result in the abandonment of one or more facilities of the project occupant within the state. Regardless, the CUB Project is not a retail or commercial project. It is a hospital or health-related project for which OCIDA does not have jurisdiction or authority, as discussed in our previous comments.

Overall, CUB (and MVHS) has not submitted sufficient data, reports, analysis and documents to support its claims in the application and at the Public Hearing that purportedly form the basis for taking by eminent domain for a public purpose. A decision to take property by eminent domain should not be based on lip service or flimsy information with insufficiently supported claims of public purpose.

OCIDA has also failed to comply with the requirements of GML § 859, GML § 859-a and OCIDA's uniform tax exemption policy and lacks authority to act. The letters, comments and exhibits submitted show a failure to comply with OCIDA's uniform tax exemption policy and thereby GML § 859-a.

For all the foregoing reasons and those we have already submitted, it would be outrageous and unlawful for OCIDA to take the Property by eminent domain.

Thank you for your attention to this matter. Please include this letter and the enclosures in the Public Hearing record. If you have any questions or concerns, please do not hesitate to contact me.

# **EXHIBIT A**

# BROWN DUKE & FOGEL, P.C.

ATTORNEYS AND COUNSELORS AT LAW

WWW.BDFLEGAL.COM

Patrick D. Donnelly, Esq.  
Brown Duke & Fogel, P.C.  
120 Madison Street, Suite 1620  
Syracuse, New York 13202  
[pdonnelly@bdflegal.com](mailto:pdonnelly@bdflegal.com)  
Tel: 315-399-4343

December 13, 2021

## Via Email

Shawna Papale, Secretary/Executive Director  
Oneida County Industrial Development Agency  
584 Phoenix Drive  
Rome, New York 13441-4105  
[info@mvedge.org](mailto:info@mvedge.org)  
[spapale@mvedge.org](mailto:spapale@mvedge.org)

**Re: FOIL request regarding Central Utica Building, LLC  
Application for Financial Assistance**

Dear Executive Director Papale:

This is a request pursuant to the Freedom of Information Law ("FOIL") for copies of the following public records:

1. Central Utica Building, LLC Application for Financial Assistance (the "Application"), which Application was submitted on or about November 12, 2021 to the Oneida County Industrial Development Agency ("OCIDA").
2. All records relating to the above referenced Application.

The request for all records relating to the above referenced Application includes but is not limited to all submissions of any documents, forms, letters, emails or other records by Central Utica Building, LLC to OCIDA, letters and emails by OCIDA to Central Utica Building, LLC, letters and emails by any person or entity referencing or commenting on the Application, notices, agendas, minutes or any other record related to the Application or involving any aspect of the Application or meetings or hearings related to the Application.

If you deny any of this request, please cite each exemption you feel justifies the denial and notify me of the appeal procedures. Thank you.

Sincerely,  
BROWN DUKE & FOGEL, P.C.

By:   
Patrick D. Donnelly, Esq.

Anthony J. Picente Jr.  
County Executive

Shawna M. Papale  
Secretary/  
Executive Director

Jennifer Waters  
Assistant Secretary

ONEIDA COUNTY INDUSTRIAL  
DEVELOPMENT AGENCY

**OCIDA**



584 Phoenix Drive  
Rome, New York 13441-4105  
(315) 338-0393, fax (315) 338-5694

David C. Grow  
Chairman

Michael Fitzgerald  
Vice Chairman

Mary Faith Messenger  
Treasurer

Ferris Betrus Jr.  
Eugene Quadraro  
Stephen Zogby  
Kirk Hinman

January 13, 2022

**VIA ELECTRONIC MAIL: [pdonnelly@bdflegal.com](mailto:pdonnelly@bdflegal.com)**

Patrick D. Donnelly, Esq.  
Brown Duke & Fogel, P.C.  
120 Madison Street, Suite 1620  
Syracuse NY 13202

**Re: FOIL Request Regarding Central Utica Building, LLC  
Application for Financial Assistance**

Dear Mr. Donnelly:

Oneida County Industrial Development Agency has reviewed its records relating to the above-referenced subject. Attached please find all documents that we believe to be responsive to your request. We are not delivering confidential communication between the IDA and our attorneys that is protected under CPLR § 4503(A)(1), as the IDA claims and has not waived that privilege.

Thank you.

Very truly yours,

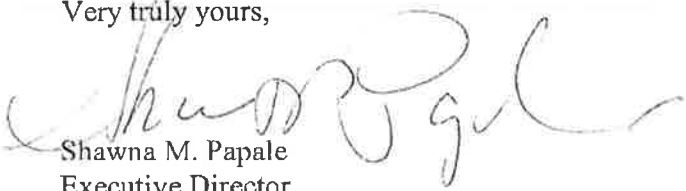
  
Shawna M. Papale  
Executive Director

SMP/lsr

Attachment

c: Linda E. Romano, Esq.  
Mark D. Levitt, Esq.



September 13, 2021

Mr. David Grow, Chairman  
Oneida County Industrial Development Agency  
584 Phoenix Drive  
Rome, New York 13441

RE: OCIDA and Oneida County's Proposed Use of Eminent Domain  
411 Columbia Street, City of Utica, New York

Dear Mr. Grow:

This letter is being submitted to you to openly question the Oneida County Industrial Development Agency (OCIDA) and Oneida County's (OC) plan to utilize eminent domain to take possession of a property that Bowers Development, LLC (BD) has under contract and plans to develop into a medical office building.

In late August 2021, OCIDA publicly announced in the Observer Dispatch that they intend to explore the use of eminent domain to take the commercial property, located at 411 Columbia Street, in the City of Utica. Since there is an upcoming OCIDA board meeting on the agenda for this week to discuss and potentially vote on this matter, I want to make sure that OCIDA / OC have a full understanding of our plans. Questions that I would raise at this time include the following:

1. **Why hasn't anyone from OCIDA / OC taken the time to speak or meet with BD to discuss their plans for the site? Is it a foregone conclusion that OCIDA / OC are just going to take this property for MHVS / CNY Cardiology without any type of responsible due diligence?** In fairness to OCIDA / OC, if MHVS did not provide you with all of the pertinent details we would not be surprised. MHVS has repeatedly and incorrectly stated that our purchase of the site is somehow an attempt to sabotage "their project." Nothing could be further from the truth. In fact, we believe our development would only enhance the MHVS campus. Last week, we heard that one of the MHVS board members didn't know of our plans for the site and was utterly shocked to see our rendering / development plans. The levels to which certain members of the MHVS team will act to suppress the BD plans in order to benefit CNY Cardiology (the real beneficiary) is appalling.
2. **Do all of the OCIDA / OC members know that the taking of this property is to ultimately benefit CNY Cardiology and not MHVS?** This is an important distinguishing factor for everyone to contemplate, as the proposed OCIDA / OC eminent domain action will potentially involve the taking of property to benefit one private group (CNY Cardiology) over another private group (BD). It is not MHVS as they would like everyone to believe.
3. **Do all of the OCIDA / OC members know that the CNY Cardiology project involves an 80,000 SF office building with one medical practice in the ownership structure (CNY Cardiology), while the BD project involves a 150,000 SF building with multiple medical practices in the ownership structure?** This is also very important for everyone to understand, as eminent domain case law revolves around the highest-and-best use for the property. Our larger medical office building project will provide more medical services to the local community rather than simply focusing on the revenues of CNY Cardiology alone, which seems to be the intent of MHVS.



4. **Why have several individuals called us to inform us that members of OCIDA / OC been telling people throughout the community that they are moving forward with taking the property, when this matter is supposed to be tabled / discussed (and possibly voted on) during the next OCIDA board meeting on Friday, September 17<sup>th</sup>?** While we do not want to believe these rumors, the frequency and extent to which we have heard such comments are very disturbing, as it suggests that the outcome of the upcoming Friday board meeting has already been determined without any discussion or dialogue with BD.
  
5. **Has anyone from OCIDA / OC researched the legal implications of taking this property, when BD clearly has a larger and better medical office building development project planned for the site?** A recent New York Supreme Court case (*Matter of 730 Equity Corp. vs. New York State Development Corp.*), which was upheld after an appeal, changed the perception of eminent domain and how it is now interpreted. We strongly believe that we have the "highest-and-best use" of the property in our development plans. An uninformed march toward eminent domain would only lead to protracted litigation and legal proceedings (which is not in anyone's best interest). Though we are confident that we would prevail, the outcome would be detrimental to the community, which we would prefer to avoid.

We remain optimistic that OCIDA / OC will investigate this matter further and realize in short order that they have not been provided all of the facts / details by MHVS, rather only provided what certain members have wanted to pass along and put in front of your respective organizations.

If you have any questions related to our proposed development plans and would like to hear more about them, please let us know and we would be happy to meet with OCIDA / OC to discuss them at your earliest convenience.

Sincerely,  
Bowers Development, LLC

A handwritten signature in black ink, appearing to read "Bryan Bowers", written over a white background.

Bryan Bowers  
Managing Member

Cc: Michael Fitzgerald, Vice Chair (OCIDA)  
Mary Faith Messenger, Treasurer (OCIDA)  
Shawna Papale, Secretary / Executive Director (OCIDA)  
Jennifer Waters, Assistant Secretary (OCIDA)  
Ferris Betrus, Jr. (OCIDA)  
Kirk Hinman (OCIDA)  
Eugene F. Quadraro (OCIDA)  
Stephen R. Zogby (OCIDA)  
Anthony J. Picente, Jr., County Executive (OC)



**From:** Bruce A. Smith  
**To:** Dave Quirello; Shawna Papale  
**Subject:** Re: Eminent Domain  
**Date:** Monday, September 20, 2021 1:02:53 PM  
**Attachments:** image003.png  
image003.png

---

We need to speak with OCIDA counsel.

Get [Outlook for iOS](#)

---

**From:** Dave Quirello <dquirello@cnycardiology.com>  
**Sent:** Monday, September 20, 2021 11:28:56 AM  
**To:** 'Shawna Papale' <spapale@mvedge.org>  
**Cc:** 'Bruce A. Smith' <bsmith@ccblaw.com>  
**Subject:** Eminent Domain

Shawna,

Any word from legal counsel as to how to manage this process. Do we need to make an offer or is the fact that this parcel was part of the original hospital plan? I know that Tony has indicated to Dr. Kelberman that we may not need to. Bruce, do you have any questions for Shawna?

Take care.

David Quirello, CMPE  
Chief Financial Officer



Central New York Cardiology

2211 Genesee Street

Utica NY 13501

Phone: (315) 733-7598 ext. 2236

Fax: (315) 733-7694

dquirello@cnycardiology.com

**CAUTION:** This email originated from outside of the organization. Do not click links or open attachments unless you recognize the sender and know the content is safe.

**From:** [Dave Quirella](#)  
**To:** [Steven J. Dimeo](#)  
**Cc:** [Shawna Papale](#); [Charles Cronin](#); [Romano, Linda](#); [Bruce A. Smith](#)  
**Subject:** RE: MVHS - private medical office building - potential NMTC  
**Date:** Sunday, October 24, 2021 5:08:33 PM  
**Attachments:** [image005.png](#)  
[image002.png](#)

Thanks Steve. Another aspect that is key to this is the physician recruiting. We have recruited four physicians to come to Utica including three in August 2021. These newly recruited physicians possess scope and skills offering new procedures not currently available prior to their arrival. Enhancing healthcare and expansion of service further benefits the community. Please find links below that will explain the new procedures, albeit hospital based not in the ASC.

<https://mivradia.com/>

<https://www.structuredheart.com/us/index.php?id=117&id=9>

Please let me know if you have any questions

Dave Quirella, CMPE  
Chief Financial Officer



Central New York Cardiology  
2211 Genesee Street  
Utica NY 13501  
Phone: (315) 733-7598 ext 2236  
Fax: (315) 733-7694  
dquirella@cnycardiology.com

**From:** Steven J. Dimeo [mailto:[sjdimeo@mvedge.org](mailto:sjdimeo@mvedge.org)]  
**Sent:** Friday, October 22, 2021 6:17 PM  
**To:** Dave Quirella <[dquirella@cnycardiology.com](mailto:dquirella@cnycardiology.com)>  
**Cc:** Shawna Papale <[spapale@mvedge.org](mailto:spapale@mvedge.org)>; Charles Cronin <[ccmc@axiom-capital.com](mailto:ccmc@axiom-capital.com)>; Romano, Linda <[romanol@bsk.com](mailto:romanol@bsk.com)>; Bruce A. Smith <[bsmith@ccblaw.com](mailto:bsmith@ccblaw.com)>  
**Subject:** RE: MVHS - private medical office building - potential NMTC.

Dave

Thank you for follow up info. I know Dave Trevisani very well as he and I used to work together at City Hall. I had emailed him earlier after I spoke to the ESD NMTC team on this and other potential projects. Dave knows the NMTC program as well as anyone locally. I used Dave when we did the Assured Information Security Building at Griffiss in 2010. I will probably circle back with Dave next week. The MOB may be a good fit with NMTC if we can secure some allocation of tax credits. The project budget is about the right size for a decent tax credit allocation to support a piece of the project.

Regards,

Steven J. Dimeo  
President  
Mohawk Valley EDGE  
584 Phoenix Dr.  
Rome, NY 13441  
Office: (315) 338-0393  
Mobile: (315) 796-1995  
[sjdimeo@mvedge.org](mailto:sjdimeo@mvedge.org)

**From:** Dave Quirella <[dquirella@cnycardiology.com](mailto:dquirella@cnycardiology.com)>  
**Sent:** Friday, October 22, 2021 5:02 PM  
**To:** Steven J. Dimeo <[sjdimeo@mvedge.org](mailto:sjdimeo@mvedge.org)>  
**Cc:** Shawna Papale <[spapale@mvedge.org](mailto:spapale@mvedge.org)>; Charles Cronin <[ccmc@axiom-capital.com](mailto:ccmc@axiom-capital.com)>; Romano, Linda <[romanol@bsk.com](mailto:romanol@bsk.com)>; Bruce A. Smith <[bsmith@ccblaw.com](mailto:bsmith@ccblaw.com)>  
**Subject:** RE: MVHS - private medical office building - potential NMTC.

Steve,

Nice to meet you. The numbers below may vary slightly. First we are trying to right size the building base on potential parking availability. If that makes sense. Plus we are in the middle of space programming and all are still trying to figure things out. So the building may fluctuate more toward 20,000. The ASC and MVHS space has not yet been modified but CHYC may drop to 20,000. The rest is tentative as follows:

3 to 4 private practice surgical specialties totaling 10,000  
MRI Suite and Office 2500-3000 ?  
Café/Coffee Shop/ATM/etc 1,000

Please find attached some information on the PET CT. I will say that it is possible for full disclosure that Slocum may have a Multi-PET that comes occasionally but we plan to put a fixed one in. I have asked our vendor to put something better for you and will forward on Monday. This will at least give you some idea for now.

I have included our finance broker Chuck Cronin from Axiom Capital and I am sure he is familiar with the new market tax credits. Actually, I believe he may have mentioned the name Dave (relevant to me in previous conversations)

As well Linda Romano and Bruce Smith are copied as well

Please let me know if you have additional questions.

Dave Quirello, CMPT  
Chief Financial Officer



Central New York Cardiology  
2211 Genesee Street  
Utica NY 13501  
Phone: (315) 733-7598 ext. 2236  
Fax: (315) 733-7694  
[dquirello@nycardiology.com](mailto:dquirello@nycardiology.com)

**From:** Shawna Papale (<mailto:spapale@nyedge.org>)  
**Sent:** Friday, October 22, 2021 12:47 PM  
**To:** Dave Quirello <[dquirello@nycardiology.com](mailto:dquirello@nycardiology.com)>  
**Cc:** Steven J. Dimico <[sjdimico@nyedge.org](mailto:sjdimico@nyedge.org)>  
**Subject:** FW: MVHS - private medical office building - potential NMTC

Dave -- here is what Steve is asking can you help filling the gaps. I am copying Steve who is making contact on the New Market Tax Credits. Look forward to working with you, Shawna

**Location:** 601 State St., directly across from the new Mohawk Valley Health Systems (The Wynn Family Hospital) that is under construction in downtown Utica.

**Project:** Construction of an 80,000 SF Medical Office Building that will be via a ground lease to an LLC created by the developer group for the project.

**Cost:** \$20.0 M for core building and shell, with an additional \$17.2 M for building fit-out for the respective tenant space and purchase of FFBE.

**Tenants:**

- CNY Cardiology: 22,000 SF (practice has outgrown current space – new space is co-located next to hospital and provides expanded space to accommodate larger patient caseload.
- Ambulatory Surgical Center (ASC): 20,000 SF
- MVHS: 17,000 SF ( Medical Imaging, Patient Draw Lab, Neur, Adv. Endoscopy & Cardio Thoracic Surgery Clinics)
- Other physician Space: 21,000 SF (this adds up to 80,000 SF – need to have this to know what balance of occupancy is)

**Job Creation:** 37 tenant FTEs including 3 physicians for cardio group + 30 ASC position.

**Project Includes new PET CT – which is a new service line in Utica. (What is the PET CT???)**

Central Utica Building, LLC will be located at 601 State St in Downtown Utica. The project will be across the st from the newly built MV Health Systems Wynn Hosp. The project consists of property acq, design, eng & construct. of 3-4 flr 80K SF state of the art Medical Office Building. The team will invest roughly \$20MM into this new facility. Tenants will invest an added \$17.2MM building out their respective spaces & purchasing equipment. CNY Cardiology will occupy 22K, a 20K Ambulatory Surgical Center (ASC) w/6 ORs & MVHS 17K SF including Medical Imaging, Patient Draw Lab, Neuro, Adv Endoscopy & Cardio Thoracic Surgery Clinics. The project creates 37 tenant FTEs including 3 physicians for Cardio group & 30 ASC positions. CNY Cardio has grown to almost 30 providers, outgrowing their current space. With the 3 new physicians each provider is reduced to a single exam room b/c of physical capacity. Providers prefer to work w/2 rooms so patients can be prepped & data captured. We see less patients due to lack of space. The relocation inc a PET CT, a new service line in the Utica Office. It is essential to the wellbeing of their business & community to expand to a larger location

<https://www.new-markets-tax-credits.com/>

## Tax Credit Financing



The New Markets Tax Credit (NMTC) program provides up to 15% - 20% cash grant funding for real estate projects, businesses and non-profits that make investments in distressed areas. This page outlines how these tax credits work, the application process and how you can obtain them for your project.

#### **About The Author - Adam Tkaczuk**

Adam Tkaczuk has secured over \$500,000,000 of tax credit financing for real estate projects, businesses and non-profits. He is the Principal of [Sterling Point Capital](#) and tax partner at the private equity firm [Ventens Industrial Holdings](#). You can contact Adam by email at [Adam@SterlingPointCapital.com](mailto:Adam@SterlingPointCapital.com).

#### **How The NMTC Program Works**

Each year the US Treasury, through the Community Development Financial Institutions Fund (CDFI) issues New Markets Tax Credits to Community Development Entities (CDEs) who in turn seek to invest these tax credits into the most impactful projects. There are over 200 CDEs in the country and they submit applications annually to the CDFI for these tax credits. It's a highly competitive selection process such that only one out of every three CDEs win an allocation of NMTCs in any given year. Therefore, CDEs have become very specific in the types of projects they support - all in an effort to stand out from the other CDEs. For example, some CDEs focus on rural communities in one or two states while others will only invest in healthcare projects, while others only invest in projects that remediate contaminated sites (i.e., brownfields).

The CDEs that receive NMTCs will then allocate those tax credits to projects that they believe will have the largest social impacts and that align with their investment goals. The recipients can then sell the tax credits to investors which generates the cash subsidy.

#### **How Much Can You Get?**

The largest allocation of NMTCs that you can receive is equal to your total project budget. So, a \$15MM project can obtain a maximum of \$15MM in NMTCs. However, one dollar (\$1.00) of NMTCs is really a thirty-nine cent (\$0.39) federal tax credit. This tax credit can be sold at closing for cash which generates the subsidy.

In the example below, we'll assume that a \$15MM project obtains a \$10MM allocation of NMTCs. This \$10MM of NMTCs represents a \$3.9MM federal tax credit that a bank (or some other tax credit investor) will purchase. We'll assume a 30% discount such that the tax credit investor will pay \$2.7MM for \$3.9MM of tax credits. This takes the form of an interest only loan (typically at 1% interest rate) that is forgiven after 7 years. After fees, the net benefit is usually in the 15% to 20% of the total allocation of NMTCs.

#### **New Markets Tax Credits Structure:**

The NMTC structure can get complicated, but the diagram below provides a simple overview.

Referencing the chart above, you first have a bank or lender that provides a market rate loan to the project (upper left in the diagram). This can even be your own equity backed, self-sourced loan if you'd prefer. Either way, this loan is passed through the NMTC structure and remains unchanged all the way to the bottom where it is received by the project sponsor (i.e. the subsidy's recipient)

The tax credit investor on the upper right also provides cash (called an "equity investment") and receives the tax credit in return. This funding is also passed through the structure and becomes an interest only forgivable loan to the project sponsor. By law, all of this cash must pass through a CDE (Community Development Entity) in order to generate the NMTC. The CDE will take their fees out of the second loan proceeds and all other closing costs are taken from this second loan as well.

The project sponsor or subsidy's beneficiary will receive a market rate bank loan and a low rate (often 1%) interest only loan that is forgiven after seven years. After seven years, the entire structure collapses and the sponsor is left with just their market rate loan. Why seven years? That's because the New Markets Tax Credits don't fully vest until year seven and the structure must remain in place for the tax credit investor to get the full benefit of the tax credit.

#### **How to Obtain New Markets Tax Credits for Your Project:**

As a potential recipient of NMTCs, your goal is to make your project align as much as possible with the annual CDFI application and to identify which CDE's fit your project's profile. It's even better if you can get your project included in a CDE's annual application to the CDFI and to market your project to the CDE community throughout the year.

To be considered for NMTC financing, your project must:

- Be located in a qualified distressed census tract;
- Have a budget of at least five million (\$5,000,000), but ten million (\$10,000,000) or more is better;
- The project must provide a benefit to the low-income community. This could be generated by an anchor tenant that provides jobs or social services or through apartment housing or direct job creation – if those jobs are accessible to the low-income community. Private businesses, real estate developers, healthcare centers and non-profits are common recipients of these tax credits.
- Have identified all other sources of financing (NMTCs are the last money-in) and all sources of financing must abide by the NMTC program's requirements (see below)
- Priority is given to projects that are in underserved areas such as rural communities or in underserved states.
- Additional priority is given to projects that align with the current political climate. For example, when the opioid crisis was in the news, many healthcare centers that served impacted individuals were funded. Further, when Opportunity Zones were new, many projects that were located in these areas were funded.
- Finally, CDEs are under tremendous pressure to fund projects within a certain timeframe. If your project has all other financing lined up, all approvals are in place, and you can close quickly - you stand a good chance of getting an allocation before another project that is delayed.

#### **Important Financing & Collateral Requirements:**

One issue with the NMTC program is that your lender must take second position against any collateral for a period of seven years. The reason for this is that the tax credit investor is paying you upfront for the tax credits but the tax credits don't fully vest until the seventh year. If there's a default in the project, then they lose their tax credits and their investment. To cover this risk, the tax credit investors require a first position on any collateral involved in the project. This is a common requirement that many of the national banks who fund these projects understand and are willing to work with.

#### **What I do and How I can Help:**

I've secured nearly \$50,000,000 of New Markets Tax Credits for projects and raise over \$500,000,000 of tax credit financing for businesses, real estate projects and nonprofits. If you'd like to learn more about the NMTC program or if you'd like help obtaining these tax credits for your project, please feel free to [contact me](mailto:adam@stereingpoint.com).

*"ACME worked with Adam to successfully secure economic development funding.. not only did his efforts yield \$4.5M in direct support for our company's growth, his network of contacts and ability to get to just the right person (for our unique situation) made it happen in record time. He is always the consummate professional, extremely diligent and detail oriented in his efforts, and has a knack for "seeing" the best path forward quickly. If that's not enough, he's a delight to be around and fun to work with. If you ever have occasion to take advantage of his deep financial skillset, you will not be disappointed."*

Mike Roughton  
President & CEO  
ACME Cosmetic Components

Adam Tkaczuk  
[Stereing Point Capital](mailto:Adam@StereingPointCapital.com)  
Phone: 347-920-7483  
[Email: Adam@StereingPointCapital.com](mailto:Adam@StereingPointCapital.com)

**DO YOU QUALIFY? + FREE CASH FLOW MODEL**

The NMTC program requires that projects be located in qualifying census tracts among other criteria. To determine if your project could qualify, complete the form below and I'll provide immediate guidance. I can also generate a free NMTC cash flow model for your project that shows all fees and not benefits.

CAUTION: This email originated from outside of the organization. Do not click links or open attachments unless you recognize the sender and know the content is safe.

CAUTION: This email originated from outside of the organization. Do not click links or open attachments unless you recognize the sender and know the content is safe.

CAUTION: This email originated from outside of the organization. Do not click links or open attachments unless you recognize the sender and know the content is safe.



**From:** Bruce A. Smith  
**To:** Shawna Papale; "pgoldman@goldmanpllc.com"  
**Subject:** RE: OCIDA letter of intent  
**Date:** Thursday, October 28, 2021 11:29:06 AM

---

Just checking in. Let me know when we can send the letter to OCIDA. thanks

Bruce A. Smith, Esq.  
Cohen Compagni Beckman Appler & Knoll, PLLC  
507 Plum Street, Suite 310  
Syracuse, New York 13204  
Direct Phone: (315) 477-6291  
Direct Fax: (315) 425-3691  
E-mail: [bsmith@ceblaw.com](mailto:bsmith@ceblaw.com)  
Website: [www.ceblaw.com](http://www.ceblaw.com)

**This electronic transmission contains information from the law firm of Cohen Compagni Beckman Appler & Knoll, PLLC, which is confidential, covered by the attorney-client privilege, and solely for the person or entity named above. If you are not the intended recipient, be aware that any disclosure, copying, distribution or use of this information is prohibited. If you have received this electronic mail transmission in error, please notify us by telephone, mail or electronic mail and destroy this communication.**

**From:** Bruce A. Smith  
**Sent:** Tuesday, October 26, 2021 4:34 PM  
**To:** 'Shawna Papale' <[spapale@mvedge.org](mailto:spapale@mvedge.org)>; 'pgoldman@goldmanpllc.com' <[pgoldman@goldmanpllc.com](mailto:pgoldman@goldmanpllc.com)>  
**Subject:** OCIDA letter of intent

Shawna and Paul

Here is a draft of the letter of intent that Shawna asked us to submit. OK with Kevin Bernstein and Linda Romano. Let me know what you think.

Bruce

**CAUTION:** This email originated from outside of the organization. Do not click links or open attachments unless you recognize the sender and know the content is safe.



**From:** [Dave Quirello](#)  
**To:** [Shawna Papale](#)  
**Subject:** Letter of Intent  
**Date:** Friday, October 29, 2021. 1:44:47 PM  
**Attachments:** [image003.png](#)  
[IDA Letter of Intent - Executed.pdf](#)

---

Hi Shawna,

Please find the executed letter of intent from Central Utica Building. We are about 90% complete on the application and will then it will get circulated to the attorneys.

David Quirello, CMPE  
Chief Financial Officer



Central New York Cardiology

2211 Genesee Street

Utica NY 13501

Phone: (315) 733-7598 ext. 2236

Fax: (315) 733-7694

dquirello@cnycardiology.com

**CAUTION:** This email originated from outside of the organization. Do not click links or open attachments unless you recognize the sender and know the content is safe.

CENTRAL UTICA BUILDING, LLC

October 26, 2021

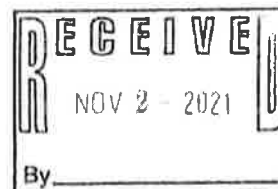

BY E-MAIL AND REGULAR MAIL

Oneida County Industrial Development Agency  
584 Phoenix Drive  
Rome, New York 13441  
Attn: Shawna M. Papale, Executive Director

Ladies and Gentlemen:

This letter is to notify OCIDA of our intention to promptly submit an Application for Financial Assistance in connection with our proposal to develop a 70,000-80,000 square foot medical office building (the "MOB") adjacent to, and within the footprint of the new Wynn Hospital of the Mohawk Valley Health System (the "Wynn Hospital"). The principal tenants of the MOB will be (i) Central New York Cardiology, P.C.—a 30 provider cardiology medical group, (ii) a for-profit joint venture comprised of Mohawk Valley Health System ("MVHS") and local physicians which will own and operate a six OR Medicare-certified multi-specialty ambulatory surgery center and (iii) MVHS-owned specialty medical clinics and ancillary services such as lab and diagnostic radiology.

The MOB will significantly enhance and/or expand the delivery of health care services to the community. The location of the MOB adjacent to the Wynn Hospital will enable the development of a seamless and integrated health care delivery system among the Wynn Hospital and providers located in the MOB thereby improving the quality and accessibility of health care services in the community.

To accommodate the MOB's parking requirements the property located at 411 Columbia Street, tax map number 318.041-2-38 (the "O'Brien Property") must be included in the MOB's property assemblage. Otherwise, the MOB project cannot go forward. The owner of the O'Brien Property is either unable or unwilling to sell the property. We will coordinate with OCIDA to ensure to ensure all proper steps are taken to acquire this property prior to resorting to eminent domain.

Our Application will request the following:

- A. Sales tax and mortgage recording tax exemptions; and
- B. Acquisition of the O'Brien Property by eminent domain

Thank you.

Very truly yours,

A handwritten signature in black ink, appearing to read "Ashok Patel".

Ashok Patel, M.D.

**From:** [Dave Quirello](#)  
**To:** [Shawna Papale](#)  
**Subject:** Draft Application  
**Date:** Wednesday, November 10, 2021 2:01:49 PM  
**Attachments:** [image003.png](#)  
[Attachment \(Nov 10\).pdf](#)  
[QCIDA Application \(Nov 10\).pdf](#)

---

Shawna,

Please see the attached draft application. Let me know if you have any questions and assistance in the cost benefit analysis.

Take care.

David Quirello, CMPE  
Chief Financial Officer



**Central New York Cardiology**

2211 Genesee Street

Utica NY 13501

Phone: (315) 733-7598 ext. 2236

Fax: (315) 733-7694

dquirello@cnycardiology.com

**CAUTION:** This email originated from outside of the organization. Do not click links or open attachments unless you recognize the sender and know the content is safe.

ONEIDA COUNTY INDUSTRIAL  
DEVELOPMENT AGENCY



## APPLICATION FOR FINANCIAL ASSISTANCE

### **Oneida County Industrial Development Agency**

584 Phoenix Drive

Rome, New York 13441-1405

(315) 338-0393 telephone

(315) 338-5694 fax

Shawna M. Papale, Executive Director

spapale@mvedge.org

Please submit the signed and notarized completed application (Pages 1-25 ONLY), which must include any applicable addendum or supplemental information requested in the application, along with payment of a non-refundable \$500 Application Fee and a \$1,000 Commitment Fee (will be applied to final closing costs) to the Oneida County Industrial Development Agency, 584 Phoenix Drive, Rome NY 13441-1405, within 14 days prior to the OCIDA Board of Directors meeting at which you want the Application to be included on the Agenda. Wire transfer and ACH payments are acceptable but all related fees incurred by the Agency are payable by the Applicant. An electronic version of the application must accompany the original application via physical media or e-mail.

CENTRAL UTICA BUILDING

Project Name

Date of Submission

11/12/2021

### **Important Notes to Applicant:**

Upon the submission of this application to the OCIDA, the application becomes a public document. Be advised that any action brought before the Agency is public information. All agendas for the OCIDA are issued publicly prior to the full agency meeting. **IF THERE IS INFORMATION SUBMITTED THAT THE APPLICANT BELIEVES IS PROPRIETARY, PLEASE IDENTIFY IT AS SUCH AND THAT INFORMATION WILL BE TREATED CONFIDENTIALLY TO THE EXTENT PERMITTED BY LAW.**

The information requested by this application is necessary to determine the eligibility of your project for OCIDA benefits. Please answer all questions and respond "Not Applicable", "NA", or "none" where appropriate. If you're response is an estimate, please indicate so. Attach additional sheets if more space is needed for a response. **All applications must include a completed and signed NYS SEQR form and Cost Benefit Analysis form (please consult with OCIDA) before the application is considered complete.**

By signing and submitting this Application, the Applicant acknowledges that it received a copy of the Uniform Tax Exemption Policy and the Oneida County IDA Penalty for Failure to Meet Employment Levels as adopted by the Agency and Agency Memorandums pertaining to the benefits of projects financed through the Agency.

A project financed through the Agency involves the preparation and execution of significant legal documents. Please consult with an attorney before signing any documents in connection with the proposed project. You will receive an engagement letter from the OCIDA legal counsel. You will be asked to sign the engagement letter acknowledging you will be responsible for all legal fees of OCIDA legal counsel and that you understand the process. Should you not close and legal services have been rendered by the OCIDA legal counsel, Applicant will be responsible for those costs.

If your project requires a public hearing, a representative of the applicant is required to be present. A date will be coordinated by the OCIDA legal counsel.

If you have any questions how to calculate the OCIDA's application fee please refer to the enclosed Memorandum to Companies -Sale Leaseback Transactions or contact the OCIDA.

Please submit the signed and notarized completed application along with payment of a non-refundable **\$500 Application Fee** and a **\$1,000 Commitment Fee** (will be applied to final closing costs) to the **Oneida County Industrial Development Agency**, 584 Phoenix Drive, Rome NY 13441-1405, **within 14 days prior to the OCIDA Board of Directors meeting at which you want the Application to be included on the Agenda.** Wire transfer and ACH payments are acceptable but all related fees incurred by the Agency are payable by the Applicant. An electronic version of the application must accompany the original application via physical media or e-mail.

**Part I: Applicant Information**

**Note:** In responding to the following questions, please keep in mind that the Applicant will be party to all of the documents and is the individual or if entity will be formed which will receive the actual financial assistance from the Agency.

**Applicant**

1(a) Applicant's Legal Name: Central Utica Building, LLC

1(b) Principal Address: 2211 Genesee Street

Utica NY 13501

1(c) Telephone/Facsimile Numbers: (315) 733-7598

1(d) Email Address: dquirello@cnycardiology.com

1(e) Federal Identification Number: 86-3656655

1(f) Contact Person: David Quirello

1(g) Is the Applicant a  Corporation:  
If Yes, Public  Private   
If public, on which exchange is it listed?

- Subchapter S
- Sole Proprietorship
- General Partnership
- Limited Partnership
- Limited Liability Corporation/Partnership
- Single-Member LLC (name and EIN below):

Name: \_\_\_\_\_  
EIN #: \_\_\_\_\_

- DISC
- Other(specify) \_\_\_\_\_

1(h) State of Organization (if applicable) New York

**Applicant's Stockholders, Members, Directors and Officers, Partners**

2(a) Provide the following information with respect to parties with 15% or more in equity holdings:

<u>Name</u>	<u>Address</u>	<u>Percentage of Ownership</u>
Central Utica Building LLC (CUB) is owned as follows:  CNYC Realty, LLC - 30% 5DOCS, LLC -70%		

2(b) Is the Applicant, or any of the individuals listed in 2(a) above, related directly or indirectly to any other entity by more than 50% common ownership? If Yes, indicate name of such entity and the relationship.  Yes  No

The members of CNYC Realty, LLC and 5DOCS, LLC are shareholders of Central New York Cardiology, P.C.

2(c) Is the Applicant affiliated with any other entity, directly or indirectly, other than as listed in the response to 2(a) above? If Yes, please indicate name and relationship of such other entity and the address thereof:  Yes  No

**Applicant's Counsel and Accountant**

**3(a) Applicant's Attorney**

Name/Title: Bruce Smith  
Firm: Cohen Compagni Beckman Appler & Knoll, PLLC  
Address: 507 Plum Street, Suite 310  
Syracuse NY 13204  
Telephone/Fax: (315) 477-6291  
Email: bsmith@ccblaw.com

**3(b) Applicant's Accountant**

Name/Title: Allison Greco  
Firm: D'Arcangelo & Co., LLP  
Address: 120 Lomond Court  
Utica NY 13502  
Telephone/Fax: (315) 735-5216  
Email: agreco@darcangelo-cny.com

**Business Description**

**4(a)** Describe the nature of your business and principal products and/or services. Attach additional sheets if necessary.

Central Utica Building, LLC proposes to construct an approximately 70-80,000 square foot state-of-the-art medical office building (the "MOB") adjacent to the new Wynn Hospital of the Mohawk Valley Health System. As discussed in 5(a) below, the MOB will be occupied primarily by Central New York Cardiology, P.C. (~20-22,000 sf), Mohawk Valley ASC, LLC, a for-profit physician-hospital joint venture owned by MVHS and local physicians that will construct and operate an Article 28 multi-specialty ambulatory surgery center (~18,000 sf) and Mohawk Valley Health System ("MVHS") (~14-17,000 sf) for various specialty medical clinics and other services.



**Part II: Project Information**

**5(a)** Explain your project in detail. This description should include explanation of all activities which will occur due to this project. Attach additional sheets if necessary.

See Attachment

**Reasons for Project**

**6(a)** Please explain in detail why you want to undertake this project.

See Attachment

**6(b)** Why are you requesting the involvement of the Agency in your project?

The sales tax and mortgage recording tax benefits provided by the Agency are an important part of the financing plan for the MOB and for CNYC's tenant improvement build out and its acquisition of FF&E, including medical equipment.

Acquiring the parcel of property located at 411 Columbia St./Site Tax Map 318.041-2-38 (the "O'Brien Parcel") to provide patient parking for the MOB is critical. Without this property it will be impractical if not impossible to construct the MOB as proposed. If CUB is unable to acquire the O'Brien Parcel from the property owner CUB will request that the Agency acquire the property through eminent domain.

6(c) Please confirm by checking the box below, if there is the likelihood that the Project would not be undertaken **BUT FOR** the Financial Assistance provided by the Agency.

Yes     No

If the Project could be undertaken without Financial Assistance provided by the Agency, ("**No**" is checked above) then provide a statement in the space provided below indicating why the Agency should approve the requested assistance:

In addition to the need for the requested financial assistance, this project should be undertaken by the Agency because (i) the services provided by the MOB's tenants are needed in the community; (ii) the location of the MOB--and the health care services provided by its tenants--will allow for the development of an integrated health care delivery system among the Wynn Hospital and physician providers improving the quality and accessibility of health care services in the community.

How will the Applicant's plans be affected or scaled back if Agency approval is not granted?

It is likely that the MOB would not be built in a location in downtown Utica adjacent to the Wynn Hospital, a location preferred by the Wynn Hospital, the MOB's proposed tenants and the patient populations of both.

6(d) Is the proposed project reasonably necessary to discourage the Applicant from removing such other plant or facility to a location outside the State of New York?

Yes     No    If Yes, please explain briefly.

6(e) Will financing by the Agency result in the removal or abandonment of a plant or other facility of the applicant or any related entity presently located in another area of New York State?

Yes     No

If Yes, is the proposed project reasonably necessary to preserve the competitive position of the Applicant in its respective industry?     Yes     No

If Yes, please provide a statement and evidence supporting the same. Include the name of all taxing jurisdictions in which the abandoned facility or plant lies, and whether Applicant has had any discussions with said taxing jurisdictions regarding the abandonment. Please provide as much detail as possible.

6(f) Has the Applicant or any related entity previously secured financial assistance in Oneida County (whether through the Agency, the Empire State Development Corporation, or any other entity)?  Yes  No

If Yes, please explain (indicate date of benefit, location of facility and outstanding balance).

6(g) Has the Applicant or any related entity secured financial assistance anywhere within the United States within the last 90 days or does the Applicant or any related entity anticipate receiving financial assistance within the next 90 days?  Yes  No

If Yes, please explain.

6(h) Check all categories best describing the type of project for all end users at project site (you may check more than one; if checking more than one indicate percentage of square footage the use represents):

Please provide percentage of sq. footage for each use (if more than one category):

- |                                     |                                |                      |   |
|-------------------------------------|--------------------------------|----------------------|---|
| <input type="checkbox"/>            | Manufacturing                  | <input type="text"/> | % |
| <input type="checkbox"/>            | Industrial Assembly or Service | <input type="text"/> | % |
| <input type="checkbox"/>            | Back office operations         | <input type="text"/> | % |
| <input type="checkbox"/>            | Research and Development       | <input type="text"/> | % |
| <input type="checkbox"/>            | Technology/Cybersecurity       | <input type="text"/> | % |
| <input type="checkbox"/>            | Warehousing                    | <input type="text"/> | % |
| <input checked="" type="checkbox"/> | Commercial or Recreational     | 40                   | % |
| <input checked="" type="checkbox"/> | Retail                         | 60                   | % |

Addendum Required

- |                          |   |                      |   |
|--------------------------|---|----------------------|---|
| <input type="checkbox"/> | Residential housing (specify) _____                                 | <input type="text"/> | % |
| <input type="checkbox"/> | Pollution Control (specify) _____                                   | <input type="text"/> | % |
| <input type="checkbox"/> | Environmental (e.g., Brownfield) (specify) _____                    | <input type="text"/> | % |
| Addendum Required        | <input type="checkbox"/> Other (specify ie; renewable energy) _____ | <input type="text"/> | % |

6(i) Check all categories best describing the **scope of the project**:

- Acquisition of land
- Acquisition of existing building
- Renovations to existing building
- Construction of addition to existing building
- Demolition of existing building or part of building
- Construction of a new building
- Acquisition of machinery and/or equipment
- Installation of machinery and/or equipment
- Other (specify) \_\_\_\_\_

6(j) Please indicate the financial assistance you are requesting of the Agency, and provide the estimated value of said assistance. Attach a sheet labeled Annual PILOT that shows the annual utilization of the Real Property Tax Abatement by year and by taxing jurisdiction (PLEASE CONSULT WITH IDA STAFF ON PILOT CALCULATIONS).

<u>Assistance Requested</u>	<u>Estimated Values</u>
<input type="checkbox"/> Real Property Tax Abatement (value of PILOT savings)	\$ _____
<input checked="" type="checkbox"/> Mortgage Tax Exemption (.75%)	<u>128,138</u>
\$ Amount of mortgage:	<u>\$ 17,085,000</u>
<input checked="" type="checkbox"/> Sales and Use Tax Exemption ** (8.75%)	<u>\$ 1,820,000</u> (Not available for solar)
Value of goods/services to be exempted from sales tax:	<u>\$ 20,800,000</u>
<input type="checkbox"/> Issuance by the Agency of Tax Exempt Bonds(bond dollar value)\$	_____

**TOTAL EXEMPTION ASSISTANCE REQUESTED: \$ 1,948,138**

Is the financial assistance requested by the Applicant consistent with the IDA's Uniform Tax Exemption Policy?  Yes  No

**If No**, please provide a written statement describing the financial assistance being requested and detailing the reasons the IDA should consider deviating from its Policy.

\*\* Note that the estimate provided above will be provided to the New York State Department of Taxation and Finance. The Applicant acknowledges that the transaction documents will include a covenant by the Applicant that the estimate, above, represents the maximum amount of sales and use tax benefit currently authorized by the Agency with respect to this Application. The Agency may utilize the estimate, above, as well as the proposed total Project Costs as contained within this Application, to determine the Financial Assistance that will be offered. It is the responsibility of the applicant to inform the IDA within 10 days if the project amount changes.

**Part III: Facility Information**

**Attach copies of the most recent real property tax bills. Include copies for all taxing jurisdictions for the site/ facility that IDA assistance is being sought.**

**Facility (Physical Information) If multiple locations please provide information on all.**

7(a) Street Address of Facility:

601 State Street (Corner of State & Columbia)

7(b) City, Town and/or Village (list ALL incorporated municipalities):

Utica, NY

7(c) School District:

Utica City School District

7(d) For what purpose was the facility site most recently used (i.e., light manufacturing, heavy manufacturing, assembly, etc.)?

Wholesale, Service Sector

7(e) Zoning Classification of location of the project:

7(f) Please describe in detail the facility to be acquired, constructed or renovated (including number of buildings, square footage, number of floors, type of construction,) and attach plot plans, photos or renderings, if available. If there are infrastructure improvements (water, sewer, gas, electrical, etc.) please provide details along with who will carry out those improvements and who will fund them. ***Please be as specific as possible.***

See answer to 5(a) on the Attachment.

All new building utilities will be connected to the existing infrastructure ( MVWA, National Grid, Spectrum, Verizon City Storm, City/County sanitary sewers) that reside on both Columbia & State Streets and will be included in the project.

7(g) Has construction or renovation commenced?  Yes  No

**If Yes**, please describe the work in detail that has been undertaken to date, including the date of commencement.

**If No**, indicate the estimated dates of commencement and completion:

Construction Commencement: 3/2022

Construction completion: 7/2023

7(h) Will the construction or operation of the facility or any activity which will occur at the site require any local ordinance or variance to be obtained or require a permit or prior approval of any state or federal agency or body (other than normal occupancy and/or construction permits)?

Yes  No

**If Yes**, please describe.

The physician-hospital ambulatory surgery center joint venture will require certificate of need approval from the New York State Department of Health.

Has the Project received site plan approval from the Planning Department?

Yes  No  N/A

**If Yes**, please provide the Agency with a copy of the planning department approval along with the related State Environmental Quality Review (SEQR) determination. If no, please provide the status of approval:

This was included in the MVHS/Wynn Hospital site plan approval.

7(i) Will the project have a significant effect on the environment?  Yes  No

**Important: please attach and sign Part 1 of either the the long or short Environmental Assessment Form to this Application.**

7(j) What is the useful life of the facility? 100 years

7(k) Is the site in a former Empire Zone?  Yes  No

**If Yes**, which Empire Zone: \_\_\_\_\_

Is project located in a Federal HUB Zone or distressed area:  Yes  No

Provide detail.

Census Tract 264

ALL APPLICANTS MUST ANSWER PART IV-8(a)

**Part IV: Retail Project Questionnaire**

To ensure compliance with Section 862 of the New York General Municipal Law, the Agency requires additional information if the proposed Project is one where customers personally visit the Project site to undertake either a retail sale transaction or to purchase services.

**8(a).** Will any portion of the project (including that portion of the cost to be financed from equity or other sources) consist of facilities or property that are or will be primarily used in making sales of goods or services to customers who personally visit the project site?

Required  Yes or  No If the answer is YES, please continue below.  
If the answer is NO, proceed to Section Part V - Facility (Legal Info)

For purposes of Question A, the term "retail sales" means (i) sales by a registered vendor under Article 28 of the Tax Law of the State of New York (the "Tax Law") primarily engaged in the retail sale of tangible personal property (as defined in Section 1101(b)(4)(i) of the Tax Law), or (ii) sales of a service to customers who personally visit the Project.

**8(b).** What percentage of the cost of the Project will be expended on such facilities or property primarily used in making sales of goods or services to customers who personally visit the project? 60.00 %. **If the answer is less than 33% do not complete the remainder of this retail determination page and proceed to next section, Part V Facility (Pg 13)**

\* **If the answer to A above is Yes AND the answer to B above is greater than 33.33%, indicate which of the following questions below apply to the project:**

1. Will the project be operated by a not-for-profit corporation  Yes  No
2. Is the Project location or facility likely to attract a significant number of visitors from outside Oneida County?  
 Yes  No

**If yes,** please provide a third party market analysis or other documentation supporting your response.

3. Is the predominant purpose of the project to make available goods or services which would not, but for the project, be reasonably accessible to the residents of the municipality within which the proposed project would be located because of a lack of reasonably accessible retail trade facilities offering such goods or services?

Yes  No

**If yes,** please provide a third party market analysis that demonstrates that a majority of the project's customers are expected to come from outside of Oneida County and the project will not directly compete with existing businesses located in Oneida County.

**Part V: Facility (Legal Information)**

**9(a)** With respect to the **present owner** of the land or facility, please give the following information and provide a brief statement regarding the status of the acquisition.

*(Note: the present owner is not necessarily the user of the facility, but that party which holds legal title to the facility.)*

Legal Name: Mohawk Valley Health System

Address: \_\_\_\_\_

Telephone: \_\_\_\_\_

Balance of Mortgage: N/A

Holder of Mortgage: N/A

If the Applicant is not the present owner of the facility, please attach any written agreements and contracts concerning the acquisition of the real property and/or equipment.

See Attachment

**9(b)** Is there a legal relationship, directly or indirectly, by virtue of common control or through related persons, between the Applicant and the present owner of the facility?  
 Yes  No. **If Yes**, please explain.

**9(c)** Will a related real estate holding company, partnership or other entity, be involved in the ownership structure of the transaction?  
 Yes  No. **If Yes**, please explain.

CUB will acquire the property by ground lease or purchase, construct the MOB and lease space within the MOB.

**9(d)** Will the title owner of the facility/property also be the user of the facility?  
 Yes  No **If Yes**, please explain.



9(e) Is the Applicant currently a tenant in the facility?  Yes  No

9(f) Are you planning to use the entire proposed facility?  
 Yes  No

If **No**, please give the following information with respect to tenant(s) which will remain in the facility after the completion of the project, including the square footage the Applicant will occupy:

Name of Tenant	Floors Occupied	Sq. Ft. Occupied	Nature of Business
See Attachment			

9(g) Are any of the tenants related to the owner of the facility?  
 Yes  No **If Yes**, please explain.

Central New York Cardiology, P.C. is an affiliate of CUB.

9(h) Will there be any other users utilizing the facility?

Yes  No

If **Yes**, please explain. Provide detail of the contractual arrangement including any financial exchange for the use of the site or property.

All tenants of the building will be signing 10-30 year leases.

#### Part VI: Equipment

10(a) List the principal items or categories of equipment to be acquired as part of the project. If you are requesting sales tax exemption it is important to be as detailed as possible. (If a complete list is not available at time of application, as soon as one is available but prior to final authorizing resolution, please submit a detailed inventory of said equipment to be covered.) Attach a sheet if needed.

Medical equipment, computer equipment, furniture, etc.

10(b) Please provide a brief description of any equipment which has already been purchased or ordered, attach all invoices and purchase orders, list amounts paid and dates of expected delivery. Attach a sheet if needed.

No equipment has been purchased or ordered.

10(c) What is the useful life of the equipment? \_\_\_\_\_ years

**Part VII: Employment Information**

"FTE" shall mean a full time employee that has a minimum of thirty-five (35) scheduled hours per week, or any combination of two or more part-time employees that work a minimum of fifteen (15) scheduled hours per week, when combined together, constitute the equivalent of a minimum of thirty-five (35) scheduled hours per week, and whose workplace location is the project facility. For this purpose an employee shall include a leased employee regularly retained by the company.

**11(a)** Estimate how many construction jobs will be created or retained as a result of this project.

100

**11(b)** Will the project preserve permanent, private sector jobs or increase the overall number of permanent, private sector jobs in the State of New York?

Yes  No **If Yes**, explain below.

See Attachment

**11(c)** Have you experienced any employment changes (+ or -) in the last three (3) years?

Yes  No **If Yes**, explain below.

**11(d)** Job Information related to project \*\*\*

Estimate below how many jobs will be created and retained as a result of this project, if OCIDA assistance is granted. **PLEASE MAKE SURE TOTAL PART-TIME EMPLOYEES ARE TURNED INTO FULL-TIME EQUIVALENTS (FTE) for Line B. - See Pg. 17.**

Number of Jobs BEFORE Project	Location 1	Location 2	Location 3	Location 4	Location 5	
Address in NYS	2211 Genesee St Utica NY	1656 Champlin Ave, Utica, NY				<b>Total</b>
Full-Time Company	116	23				139
Full-Time Independent Contractors						
Full-Time Leased						
<b>A. Total Full-Time BEFORE</b>	<b>116</b>	<b>23</b>				<b>139</b>
Part-Time Company	15					15
Part-Time Independent Contractors	5					5
Part-Time Leased						
<b>B. Total FTE Part-Timers BEFORE</b>	<b>7.5</b>					<b>7.5</b>
<b>C. Total FTE BEFORE*</b>	<b>123.5</b>	<b>23</b>				<b>146.5</b>

\*For **Total FTE BEFORE** add full-time employees (line A) plus part-time employees that have been converted to FTE (line B).

Number of Jobs AFTER Project (within 3 years of project completion)	Location 1	Location 2	Location 3	Location 4	Location 5	Total
Full-time Company	121	32				153
Full-Time Independent Contractors						
Full-Time Leased						
<b>A. Total Full-Time AFTER</b>	<b>121</b>	<b>32</b>				<b>153</b>
Part-Time Company	16					16
Part-Time Independent Contractors	5					5
Part-Time Leased						
<b>B. Total FTE Part-Timers AFTER</b>	<b>7.9</b>					<b>7.9</b>
<b>C. Total FTE AFTER *</b>	<b>128.9</b>	<b>32</b>				<b>160.9</b>

*For Total FTE AFTER add full-time employees (line A) plus part-time employees that have been converted to FTE (line B).*

Estimate the number of residents from the Labor Market Area** in which the Project is located that will fill the jobs created within three years of project completion	Location 1	Location 2	Location 3	Location 4	Location 5	Total
<b>A. Full-Time</b>	4	8				12
<b>B. FTE Part-Timers</b>						0
<b>C. Total AFTER</b>	<b>4</b>	<b>8</b>				<b>12</b>

\*\* Labor Market Area includes Oneida, Lewis, Herkimer, and Madison Counties

Provide Any Notes To Job Information Below

As indicated above CNYC Cardiology has recruited 3 physicians to the region in August of 2021 as part of the strategic growth. Due to that fact the practice anticipates hiring 3 LPN's and an Echocardiograph Technician to keep up with the demand. Just the same we have begun to look for another cardiac physician with a subspeciality of Electrophysiology. Currently the practice employees two of these sub specialist who are in very high demand and patients sometimes have to wait weeks or longer for a consultation.

The ASC will create 9-10 new positions including 2-3 management positions

Recruitment outside of the Labor Market Area will include physician and possibly C level positions.

SALARY AND BENEFITS	Retained Jobs		Created Jobs	
	Average Annual Salary per employee	Average Fringe Benefits (as a percentage of wages)	Average Annual Salary per employee	Average Fringe Benefits (as a percentage of wages)
Management	\$ 117,000	26 %	\$ 96,000	28 %
Administrative	\$ 39,111	31 %	\$ 55,120	31 %
MVHS/ASC Management	\$	%	\$ 155,772	25 %
MVHS/ASC Administrative	\$ 99,672	25 %	\$ 57,227	25 %
Physicians / Advanced Providers	\$ 496,000	15 %	\$ 425,000	15 %
Overall Weighted Average	\$ 130,795	24 %	\$ 96,975	25 %

\*\*\* By statute, Agency staff must project the number of Full-Time Jobs that would be retained and created if the request for Financial Assistance is granted. "FTE" shall mean a full time employee that has a minimum of thirty-five (35) scheduled hours per week, or any combination of two or more part-time employees that work a minimum of fifteen (15) scheduled hours per week, when combined together, constitute the equivalent of a minimum of thirty-five (35) scheduled hours per week, and whose workplace location is the project facility. For this purpose an employee shall include a leased employee regularly retained by the company.

11(e) Please list NAICS codes for the jobs affiliated with this project:

621111  
621493  
621512  
621511

**Part VIII: Estimated Project Cost and Financing**

**12(a)** List the costs necessary for preparing the facility.

LAND Acquisition	\$	750,000
Existing Building(s) ACQUISITION	\$	
Existing Building(s) RENOVATION	\$	
NEW Building(s) CONSTRUCTION	\$	30,868,891
Site preparation/parking lot construction	\$	1,611,800
Machinery & Equipment that is TAXABLE	\$	6,300,000
Machinery & Equipment that is TAX-EXEMPT	\$	
Furniture & Fixtures	\$	
Installation costs	\$	
Architectural & Engineering	\$	735,184
Legal Fees (applicant, IDA, bank, other counsel)	\$	100,000
Financial (all costs related to project financing)*	\$	642,954
Permits (describe below)	\$	140,000
Other (describe below) ie: solar decommissioning expense)	\$	1,080,000

Other:	Cost:	Subtotal \$
1. Owner's Representative	\$ 400,000	42,228,829
2. Mortgage Broker Fee	\$ 170,000	
3. Owner's Builders Risk & Insurance	\$ 56,000	
4. Building Taxes During Construction	\$ 36,000	
5. Soft Cost Contingency/Leasing Corr	\$ 290,000	
6. Miscellaneous Fees -	\$ 128,000	
		Agency Fee <sup>1</sup> \$ 130,572
		<b>Total Project Cost \$ 42,359,401</b>

\* **Bank fees, title insurance, appraisals, environmental reviews, etc.**

<sup>1</sup> See Attached Fee Schedule (Page 24) for Agency Fee amount to be placed on this line.

**Permit/Other Information**

Building Permit fees \$7/per 1,000 based on 20MM for the core & shell

**12(b)** Has the Applicant contacted any bank, financial institution or private investor with respect to financing the proposed project?  Yes  No **If Yes**, please provide details below.

Broker Agreement with Axiom Capital who is responsible for obtaining project financing for core and shell.  
Principal: Chuck Cronin 1.518.366.4000  
cmc@axiom-capital.com

**12(c)** Has the Applicant received a commitment letter for said financing? **If Yes**, please provide a copy along with this application.  Yes  No

**12(d) Sources of Funds for Project Costs**

Bank Financing: ----- \$ 29,350,000  
 Equity (excluding equity that is attributed to grants/tax credits) -- \$ 13,015,000  
 Tax Exempt Bond Issuance (if applicable) ----- \$ \_\_\_\_\_  
 Taxable Bond Issuance (if applicable) ----- \$ \_\_\_\_\_  
 Public Sources (Include sum total of all state and federal tax credits and grants) Break out individually below.----- \$ \_\_\_\_\_

Identify each Public state and federal grant/credit:

Comments:

Source  \$   
 Source  \$   
 Source  \$   
 Source  \$

CUB has made CFA application to NY Regional Economic Development Councils dated September 30, 2021. We were notified that we appear eligible to participate in the Commercial New Construction Program and persuing. Additionally will seek out new market credits.

**Total Sources of Funds for Project Costs:** \$

**Part IX: Real Estate Taxes**

**13(a)** For each tax parcel which comprises the facility, and for which assistance is being sought, please provide the following information using figures from the most recent tax year. If an increase in the assessment is anticipated due to the proposed project, please indicate the new estimated assessment amount in the **POST- PROJECT** column. Attach copies of the most recent tax bills for all jurisdictions.

Tax Map Parcel #	Current Land Assessment	Current Building Assessment	Current Total Assessment	Current Total Taxes Amount (\$)	Estimated Post-Project Assessment
318.041-2-37					
318.041-2-38					
318.041-2-39					
318.041-2-40					

**13(b)** Will the entirety of each tax parcel be subject to the PILOT?  YES  NO

**13(c)** If the entirety of each parcel will not be subject to the PILOT, will the municipality require a subdivision?  YES  NO

**\*If a subdivision is required, it is the responsibility of the Applicant to complete subdivision approval prior to commencement of the PILOT Agreement, and to provide the Agency with the tax parcel number(s) assigned.**

**13(d)** Address of Receiver of Town and/or Village Taxes (include all jurisdictions):

1 Kennedy Plaza

Utica, NY 13502

**13(e)** Address of Receiver of School Taxes:

Utica City School District

**13(f)** Has the current property owner or user been granted an Ag-District exemption on the tax map parcel anytime during the past 4 years?

Yes  No

If Yes explain below.

**13(g)** Please consult with Agency staff to complete a Cost/Benefit Analysis form to attach to this Application.

Use space below for additional information

## NYS SEQRA Environmental Review

- The applicant must complete, sign and return to the IDA **either** the Short Form Environmental Assessment Form (SEAF) **or** the Full Environmental Assessment Form (FEAF). See the NYS DEC website for the most current versions of these documents.

<https://www.dec.ny.gov/permits/6191.html>

- To determine which EAF form is appropriate for the project, the applicant should consult with its engineer or legal counsel.
- It is the IDA's strong preference that the municipality that governs the jurisdiction where the project is located (e.g., a Planning Board, Zoning Board or other supervisory board) serve as lead agency for the SEQR review.
- In limited cases, the IDA will act as lead agency, but it may lead to additional cost to the applicant if a review is required to make a determination of environmental impact.
- If another public body is serving as lead agency for the SEQR review the applicant should provide the IDA with a signed Part 2 (and Part 3 if using the Long Form) and any minutes of meetings that detail the lead agency's determination.
- The IDA cannot grant any financial assistance until the SEQR review process is complete.



## **Agency Fee Schedule**

Commitment Fee: \$1,000 – due following the initial inducement but prior to scheduling of the public hearing; this amount is non-refundable if the applicant fails to close on the project before the IDA. Upon closing with the IDA this amount is applied to the closing fees.

Bond Fees:                    ½ of 1% of total bond amount

IDA Agency Fee: PILOT, Mortgage Recording Exemption, Sales Tax Exemption:

- o Up to a \$1.0 Million project - \$5,000
- o Above \$1.0 Million project up to \$10.0 Million project – ½ of 1% of total project cost.
- o Above \$10.0 Million project – ½ of 1% of total project cost up to \$10.0 Million plus incremental increase of ¼ of 1% of total project above \$10.0 Million.
- o Any previously induced solar or renewable energy projects that have not yet proceeded to a final authorizing resolution, and are asking for an increase in benefits, will be subject to an Agency fee of one and one-half times the Agency's normal fee.

Transaction Counsel/Agency Counsel fee:

Set by Bond/Transaction Counsel based upon the nature and complexity of the transaction. This applies to bond and non-bond transactions (leasebacks, sale-leasebacks, etc).

Transaction Counsel/Agency Counsel fees for bond transactions typically will not exceed 2% of the bond amount or project costs. Transaction Counsel/Agency Counsel fees for a sale-leaseback/lease-leaseback transaction are typically \$8,500 to \$10,000 if no commercial financing is involved or \$10,000 to \$12,000 if commercial financing is involved. You will receive an engagement letter with a quote based upon the scope of your project.

Annual Fee:

For the term in which the property remains in the IDA's name, an annual lease payment is due in the amount of \$750. The first payment is due at closing and subsequent payments are due each January 1. For annual fees not paid and delinquent, a late charge of \$50 per month will be levied until such time the fee plus late charges are paid.

Other fees:

If Applicant requests the IDA enter into subsequent transactions following closing (i.e., a facility refinance), the IDA will charge a closing fee equal to 1/8 of one percent of the total reissuance, redemption, new or revised mortgage, refinancing, spreading agreement or other transaction with a minimum payment due of \$500. Applicant will also be responsible to pay any legal fees and any bank or financial institution fees the IDA incurs in connection with said transaction, throughout the term of the Agency's involvement with the facility.

## REPRESENTATIONS AND CERTIFICATION BY APPLICANT

The undersigned requests that this Application be submitted for review to the Oneida County Industrial Development Agency (the "Agency") and its Board of Directors.

Approval of the Application can be granted solely by this Agency's Board of Directors. The undersigned acknowledges that Applicant shall be responsible for all costs incurred by the Agency and its counsel in connection with the attendant negotiations whether or not the transaction is carried to a successful conclusion.

The Applicant further understands and agrees with the Agency as follows:

1. **Annual Sales Tax Filings.** In accordance with Section 858-b(2) of the New York General Municipal Law, the Applicant understands and agrees that, if the Project receives any sales tax exemptions as part of the Financial Assistance from the Agency, in accordance with Section 874(8) of the General Municipal Law, the Applicant agrees to file, or cause to be filed, with the New York State Department of Taxation and Finance, the annual form prescribed by the Department of Taxation and Finance, describing the value of all sales tax exemptions claimed by the Applicant and all consultants or subcontractors retained by the Applicant.
2. **Annual Employment, Tax Exemption & Bond Status Reports.** The Applicant understands and agrees that, if the Project receives any Financial Assistance from the Agency, the Applicant agrees to file, or cause to be filed, with the Agency, on an annual basis, reports regarding the number of people employed at the project site as well as tax exemption benefits received with the action of the Agency. For Applicants not responding to the Agency's request for reports by the stated due date, a \$500 late fee will be charged to the Applicant for each 30-day period the report is late beyond the due date, up until the time the report is submitted. Failure to provide such reports as provided in the transaction documents will be an Event of Default under the Lease (or Leaseback) Agreement between the Agency and Applicant. In addition, a Notice of Failure to provide the Agency with an Annual Employment, Tax Exemption & Bond Status Report may be reported to Agency board members, said report being an agenda item subject to the Open Meetings Law.
3. **Absence of Conflict of Interest.** The Applicant has consulted the Agency website of the list of the Agency members, officers and employees of the Agency. No member, officer, or employee of the Agency has an interest, whether direct or indirect, in any transaction contemplated by this Application, except as herein after described (if none, state "none"):
4. **Hold Harmless.** Applicant hereby releases the Agency and its members, officers, servants, agents and employees from, agrees that the Agency shall not be liable for and agrees to indemnify, defend and hold the Agency harmless from and against any and all liability arising from or expense incurred by (A) the Agency's examination and processing of, and action pursuant to or upon, the attached Application, regardless of whether or not the Application or the Project described therein or the tax exemptions and other assistance requested therein are favorably acted upon by the Agency, (B) the Agency's acquisition, construction and/or installation of the Project described therein and (C) any further action taken by the Agency with respect to the Project; including without limiting the generality of the foregoing, all causes of action and attorneys' fees and any other expenses incurred in defending any suits or actions which may arise as a result of any of the foregoing. If, for any reason, the Applicant fails to conclude or consummate necessary negotiations, or fails, within a reasonable or specified period of time, to take reasonable, proper or requested action, or withdraws, abandons, cancels or neglects the Application, or if the Agency or the Applicant are unable to reach final

agreement with respect to the Project, then, and in the event, upon presentation of an invoice itemizing the same, the Applicant shall pay to the Agency, its agents or assigns, all costs incurred by the Agency in the processing of the Application, including attorneys' fees, if any.

5. The Applicant acknowledges that the Agency has disclosed that the actions and activities of the Agency are subject to the Public Authorities Accountability Act signed into law January 13, 2006 as Chapter 766 of the 2005 Laws of the State of New York.
6. The Applicant acknowledges that the Agency is subject to New York State's Freedom of Information Law (FOIL). Applicant understands that all Project information and records related to this application are potentially subject to disclosure under FOIL, subject to limited statutory exclusions.
7. The Applicant acknowledges that it has been provided with a copy of the Agency's recapture policy (the "Recapture Policy"). The Applicant covenants and agrees that it fully understands that the Recapture Policy is applicable to the Project that is the subject of this Application, and that the Agency will implement the Recapture Policy if and when it is so required to do so. The Applicant further covenants and agrees that its Project is potentially subject to termination of Agency financial assistance and/or recapture of Agency financial assistance so provided and/or previously granted.
8. The Applicant understands and agrees that the provisions of Section 862(1) of the New York General Municipal Law, as provided below, will not be violated if Financial Assistance is provided for the proposed Project:

§ 862. Restrictions on funds of the agency. (1) No funds of the agency shall be used in respect of any project if the completion thereof would result in the removal of an industrial or manufacturing plant of the project occupant from one area of the state to another area of the state or in the abandonment of one or more plants or facilities of the project occupant located within the state, provided, however, that neither restriction shall apply if the agency shall determine on the basis of the application before it that the project is reasonably necessary to discourage the project occupant from removing such other plant or facility to a location outside the state or is reasonably necessary to preserve the competitive position of the project occupant in its respective industry.

9. The Applicant confirms and acknowledges that the owner, occupant, or operator receiving Financial Assistance for the proposed Project is in substantial compliance with applicable local, state and federal tax, worker protection and environmental laws, rules and regulations.
10. The Applicant confirms and acknowledges that the submission of any knowingly false or knowingly misleading information may lead to the immediate termination of any Financial Assistance and the reimbursement of an amount equal to all or part of any tax exemption claimed by reason of the Agency's involvement the Project.
11. The Applicant confirms and hereby acknowledges that as of the date of this Application, the Applicant is in substantial compliance with all provisions of Article 18-A of the New York General Municipal Law, including, but not limited to, the provision of Section 859-a and Section 862(1) of the New York General Municipal Law.
12. The Applicant and the individual executing this Application on behalf of the Applicant acknowledge that the Agency will rely on the representations made herein when acting on this Application and hereby represent that the statements made herein do not contain any untrue statement of a material

fact and do not omit to state a material fact necessary to make the statements contained herein not misleading.

STATE OF NEW YORK )  
COUNTY OF ONEIDA ) ss.:

**David Quirello** \_\_\_\_\_, being first duly sworn, deposes and says:

1. That I am the CFO (Corporate Office) of Central Ulica Building, LLC/CNY Cardiology, PC (Applicant) and that I am duly authorized on behalf of the Applicant to bind the Applicant.
2. That I have read the attached Application, I know the contents thereof, and that to the best of my knowledge and belief, this Application and the contents of this Application are true, accurate and complete.

\_\_\_\_\_  
(Signature of Officer)

Subscribed and affirmed to me under penalties of perjury  
this \_\_\_ day of \_\_\_\_\_, 20\_\_ .

\_\_\_\_\_  
(Notary Public)

If the application has been completed by or in part by other than the person signing this application for the applicant please indicate who and in what capacity:

By: \_\_\_\_\_

Name: Bruce Smith

Title: Esquire

Date: 11/1/2021

**Please submit the signed and notarized completed application along with payment of a non-refundable \$500 Application Fee and a \$1,000 Commitment Fee (will be applied to final closing costs) to the Oneida County Industrial Development Agency, 584 Phoenix Drive, Rome NY 13441-1405, within 14 days prior to the OCIDA Board of Directors meeting at which you want the Application to be included on the Agenda. Wire transfer and ACH payments are acceptable but all related fees incurred by the Agency are payable by the Applicant. It is advised that an electronic version of the application accompany the original application via hard copy or e-mail. An electronic version of the application must accompany the original application via physical media or e-mail.**

Anthony J. Piccitti Jr.  
County Executive

Shawna M. Papale Executive  
Director/Secretary

Jennifer Waters  
Assistant Secretary

ONEIDA COUNTY INDUSTRIAL  
DEVELOPMENT AGENCY

**OCIDA**



584 Phoenix Rome, New York 13841-8105  
Ph: (315) 338-0393, fax: (315) 348-5694  
info@ocida.org www.oneidacountyida.org

David B. Grow  
Chair

L. Michael Fitzgerald  
Vice-Chair

Mary Faith Messenger  
Treasurer

Ferris Betrus

Kirk Hinman

Eugene Quadraro

Steven Zogby

## MEMORANDUM TO COMPANIES SALE-LEASEBACK TRANSACTIONS

1. When a Company decides that a sale-leaseback transaction may suit its particular needs, the first order of business is for the Company to complete an Application for Financial Assistance, together with an Environmental Impact Questionnaire, Cost/Benefit Analysis and Statement of the Project Applicant (referred to collectively as the "Application"). The Application is submitted to Agency Counsel for a formal decision as to whether or not the project qualifies as a "project," as defined by law.
2. No action can be taken until the Application is completed and submitted to the Agency and approved by Agency Counsel.
3. Upon completion of the Application and approval by Agency Counsel, the Agency will meet for the purpose of adopting an Inducement Resolution and reviewing the Environmental Impact Questionnaire, Cost/Benefit Analysis and Statement of the Project Applicant. At this time a Resolution may be adopted by the Agency concerning the environmental impact. **Please note that the Agency is subject to the Open Meetings Law, and all meetings will be open to the public, including news media.**
4. The Company is expected and encouraged to have its own counsel. The Company is also required to reimburse the Agency for all legal expenses incurred in furtherance of a proposed transaction, whether or not that transaction is completed. This includes all fees and disbursements of Agency Counsel.
5. The Company will be asked to sign an Inducement Agreement, which sets forth the terms of the proposed transaction and the obligations of the parties in furtherance of the same. The Company will also be asked to provide Agency Counsel with certain

information concerning the formation of the corporation or partnership, a survey of the property, title insurance, insurance certificates, etc. before the transaction can close. All matters in connection with the transfer of the real estate will be handled primarily by Company Counsel with the assistance of Agency Counsel.

6. A Public Hearing may be required in accordance with the New York State General Municipal Law, after which the Oneida County Executive must approve or disapprove the issue. Notice of the Public Hearing must be published at least thirty (30) days prior to the Hearing in the newspaper where the project is located. The highest elected official of each affected taxing jurisdiction must also receive thirty day written notice of the Hearing.

No financial benefits may be granted by the Agency to the Company until after the Public Hearing is required.

7. Agency Counsel has certain requirements as to those documents which must be included in the transaction and the content thereof, including but not limited to requiring environmental impact surveys, environmental indemnifications and general indemnifications.
8. The fee schedule is attached, covering the Agency fee, the Agency's work with respect to the project and the work of Agency Counsel.

The estimated fees for Agency Counsel may vary depending on the nature of the project. The initial fee quote assumes that the transaction closes within ninety (90) days from the date of the inducement, that there will be no unusual questions of law or prolonged negotiations regarding the documents, and that the involvement or assistance from other agencies will not require substantial modifications to the typical structure and documentation of similar transactions. The fee quote also assumes that Agency Counsel will not be called upon to coordinate with any lender, as the Agency is not issuing bonds. The fee quote assumes that closing will take place by mail and will not necessitate attending meetings with the Company or any lender.

9. Once the terms and conditions of the transaction are fairly well established, Agency Counsel prepares preliminary drafts of the financing documents and distributes them to all parties for review and comment. Comments accepted by all counsel will result in redrafting of documents. The parties establish a mutually agreeable closing date, and final documents for execution are prepared.

10. The Agency then conducts a meeting whereby it adopts an Authorizing Resolution, under which the Agency approves of the form of the documents and authorizes the Chairman to execute the same.
11. The closing takes place.
12. Some of the benefits available to a company under a sale-leaseback transaction are as follows:
  - ⇒ Exemption from New York State mortgage recording tax
  - ⇒ Exemption from New York State sales tax for materials used in construction
  - ⇒ Real property tax abatement on the value added to the project (for more information, please see the Uniform Tax Exemption Policy enclosed herewith)

c:\1997\actlab\trb\memo3.doc\br\_pc

**MEMORANDUM TO APPLICANTS FINANCING AN IDA PROJECT  
THROUGH A COMMERCIAL LENDER**

We have found it helpful to outline at the onset of a transaction the basic structure of financing when an industrial development agency ("IDA") has a fee or leasehold interest in a property and is party to a mortgage or other financing instrument. **Please give a copy of this memorandum to your lender as early in the financing process as possible.**

An IDA is party to a financing instrument purely as a conduit for financial assistance (in the case of granting exemptions from mortgage recording tax) and to grant its interest in the facility to the lender. To preserve the passive nature of its role, the IDA cannot assume any obligations or make any representations that a traditional Borrower would make to a lender. It has been our experience that the easiest way to accomplish this is to define the Borrower as the "Borrower," define the IDA as the "Agency," and only include the Agency in the granting clause and with respect to the assignment of rents, inasmuch as those are the only reasons that the Agency is party to this document.

Furthermore, because PILOT Payments are contractual obligations and are not given the same high priority as tax payments, we crafted some language that will restore the taxing jurisdictions to the same position they would have been but not for the IDA involvement in the project. While it is not disputed that is an equitable arrangement, certain lenders have expressed concern that, because the requirement to pay PILOT Payments is contained in a private contract, there is no prescribed process to avoid significant delinquencies as there is under a tax foreclosure. It has been our experience the easiest way to accomplish this is for a lender to escrow PILOT Payments so it has the assurance that payments are made in a timely manner. If a lender does not wish to escrow PILOT Payments, an alternative is for the IDA to record a PILOT Mortgage that would be given first priority over the lender's mortgage, similar to the priority taxes have.

Below are certain provisions we require be incorporated into each financing document to which the IDA is a party (please modify capitalized terms accordingly):

**1. AGENCY PROVISIONS.**

a. Agency makes no covenants other than to mortgage all of its interest in the Premises excepting its Unassigned Rights (as said term is defined in the Leaseback Agreement).

b. **NO RECOURSE AGAINST AGENCY:** Lender agrees that Lender will not look to the Agency or any principal, member, director, officer or employee of the Agency with respect to the Indebtedness or any covenant, stipulation, promise, agreement or obligation contained in this Mortgage. In enforcing its rights and remedies under this Mortgage, Lender will look solely to the Premises for the payment of the Indebtedness and for the performance of the provisions hereof. Lender will not seek a deficiency or other money judgment against the Agency or any principal, member, director, officer or employee of the Agency and will not institute any separate action against the Agency by reason of any default which may occur in the performance of any of the terms and conditions of any documents evidencing the Indebtedness.

c. **HOLD HARMLESS:** Borrower and Lender agree that the Agency, its directors, members, officers, agents (except the Borrower) and employees shall not be liable for and Borrower agrees to defend, indemnify, release and hold the Agency, its directors, members, officers, agents (except the Borrower) and employees harmless from and against any and all (i) liability for loss or damage to Property or injury to or death of any and all Persons that may be occasioned by, directly or indirectly, any



cause whatsoever pertaining to the Facility or arising by reason of or in connection with the occupation or the use thereof or the presence of any Person or Property on, in or about the Facility or the Land or (ii) liability arising from or expense incurred by the Agency's financing, acquiring, constructing, renovating, equipping, owning and leasing of the Facility, including without limiting the generality of the foregoing, all claims arising from the breach by the Borrower of any of their respective covenants contained herein and all causes of action and attorneys' fees and any other expenses incurred in defending any claims, suits or actions which may arise as a result of any of the foregoing, provided that any such losses, damages, liabilities or expenses of the Agency are not incurred or do not result from the gross negligence or intentional or willful wrongdoing of the Agency, or any of its directors, members, agents (except the Borrower) or employees. The foregoing indemnities shall apply notwithstanding the fault or negligence in part of the Agency or any of its members, directors, officers, agents or employees and irrespective of the breach of a statutory obligation or the application of any rule of comparative or apportioned liability.

d. **SPECIAL OBLIGATION.** The obligations of the Agency under the Mortgage and Financing Documents constitute a special obligation of the Agency, and all charges payable pursuant to or expenses or liabilities incurred thereunder shall be payable solely out of the revenues and other moneys of the Agency derived and to be derived from the leasing of the Facility, any sale or other disposition of the Equipment and as otherwise provided in the Authorizing Resolution, the Leaseback Agreement and the PILOT Agreement. Neither the members, officers, agents (except the Borrower) or employees of the Agency, nor any person executing the Mortgage and Financing Documents on behalf of the Agency, shall be liable personally or be subject to any personal liability or accountability by reason of the leasing, construction, renovation, equipping or operation of the Facility. The obligations of the Agency under the Financing Documents are not and shall not be an obligation of the State or any municipality of the State and neither the State nor any such municipality (including, without limitation, the County of Oneida), shall be liable thereon.

e. **SUBORDINATION TO PILOT AGREEMENT:** This Mortgage shall be subject and subordinate to any PILOT Agreement between the Borrower and the Agency with respect to the payments in lieu of taxes assessed or imposed upon the Premises, and by accepting this Mortgage, Lender acknowledges and agrees that such PILOT payments shall have the same force, priority and effect as a real property tax lien under New York State law against the Premises.

If a lender chooses to escrow PILOT Payments, we will incorporate the following provisions into the Leaseback (or Lease) Agreement:

Section 9.13 Subordination to Mortgage. This Leaseback Agreement and the rights of the Company and the Agency hereunder (other than with respect to the Unassigned Rights) are subject and subordinate to the Lien of the Mortgage, and all extensions, renewals or amendments thereof. The subordination of this Leaseback Agreement to the Mortgage shall be automatic, without execution of any further subordination agreement by the Company or the Agency. Nonetheless, if the Bank requires a further written subordination agreement, the Company and the Agency hereby agree to execute, acknowledge and deliver the same.

Section 9.14 Rights of Bank.

(a) Bank is hereby given the right by the Agency, in addition to any other rights herein granted, without any requirement to obtain the Agency's consent, to mortgage the mortgagors' respective interests in the Facility and, in the case of the Company, to assign and grant a security interest in the Company's rights under the Company Documents as collateral security for its obligations to the Bank, upon the condition that all rights acquired by Bank shall be subject to all rights and interests of the

Agency herein and in the other Company Documents, none of which covenants, conditions or restrictions is or shall be waived by the Agency by reason of this right to mortgage or grant a security interest in the Facility and the Company Documents, including Unassigned Rights.

(b) There shall be no renewal, cancellation, surrender, acceptance of surrender, material amendment or material modification of this Leaseback Agreement or any other Company Document by joint action of the Agency and the Company alone, without, in each case, the prior consent in writing of Bank, nor shall any merger result from the acquisition by, or devolution upon, any one entity of any fee and/or leasehold estates or other lesser estates in the Facility. Failure of the Bank to consent to a modification of this Leaseback Agreement by the Agency shall constitute an Event of Default.

(c) If the Agency serves a notice of default upon the Company, it shall also serve a copy of such notice upon Bank at the address set forth in Section 9.1.

(d) In the event of any default by the Company under this Leaseback Agreement or any other Company Document, the Bank shall have fifteen (15) days for a monetary default and thirty (30) days in the case of any other default, after notice to the Company and the Bank of such default to cure or to cause to be cured the default complained of and the Agency shall accept such performance by or at the instigation of Bank as if same had been done by the Company. The Agency in its sole discretion will determine whether such action by the Bank amounts to a cure.

(e) Except where Bank or its designee or nominee has succeeded to the interest of the Company in the Facility, no liability for any payments to be made pursuant to this Agreement or the performance of any of the Company's covenants and agreements under this Agreement shall attach to or be imposed upon the Bank, and if the Bank or its nominee or designee succeeds to the interest of the Company in the Project, all of the obligations and liabilities of the Bank or its nominee or designee shall be limited to such entity's interest in the Facility and shall cease and terminate upon assignment of this Leaseback Agreement by the Bank; provided however, that the Bank or its nominee or designee shall pay all delinquent PILOT Payments, if any, prior to said assignment.

(g) Notwithstanding any provision of this Leaseback Agreement or any other Company Document to the contrary, foreclosure of a mortgage or any sale of the Company's interest in this Leaseback Agreement and/or the Facility in connection with a foreclosure, whether by judicial proceedings, or any conveyance of the Company's interest in this Agreement and/or the Facility to Bank by virtue of or in lieu of foreclosure or other appropriate proceedings, or any conveyance of the Company's interest in this Leaseback Agreement and/or the Facility by Bank shall not require the consent or approval of the Agency and failure to obtain the Agency's consent shall not be a default or Event of Default hereunder.

**Oneida County Industrial Development Agency Recapture Policy  
(Effective April 25, 2017)**

**DEFINITIONS:**

"Company"	is the entity that applied for and received a benefit from the Agency.
"Agency"	is the Oneida County Industrial Development Agency.
"AER"	is the Company's annual report of employment required to be provided to the Agency.
"Employment Obligation Term"	shall mean the period during which the Company is receiving a benefit in the form of lower payment in lieu of taxes than their real estate taxes would be.
"Employment Obligation"	shall mean the number of FTEs employed by the Company in Oneida County and selected by the Agency as the Company's obligation.
"FTE"	shall mean a full time employee that has a minimum of thirty-five (35) scheduled hours per week, or any combination of two or more part-time employees that work a minimum of fifteen (15) scheduled hours per week, when combined together, constitute the equivalent of a minimum of thirty-five (35) scheduled hours per week, and whose workplace location is the project facility. For this purpose an employee shall include a leased employee regularly retained by the Company.
"Benefit"	shall mean the amount the Company saved by making payments in lieu of real property taxes in a particular year. For example, if a Company's PILOT payment is equal to 75% of normal real property taxes, then the Company's Benefit for that year would be an amount equal to 25% of normal real property taxes.
"Per Employee Amount"	shall mean an amount equal to the Benefit for the year after the year of the Shortfall divided by the "Employment Obligation".
"Shortfall"	shall mean the difference between the Employment Obligation and the actual number of FTEs per the AER for the applicable year.
"Major Shortfall"	shall mean having FTEs that are less than 50% of the Employment Obligation.
"Minimum Standard"	shall mean a Company whose AER shows that they are short of meeting its Employment Obligation by 20%.
"Initial Benefit"	shall be the amount of savings the Company received through the Agency, in the form of Mortgage Recording Tax and New York State Sales Tax.
"Cure Period"	shall mean the period ending June 30 <sup>th</sup> of the year following the Major Shortfall.

1. **Job Creation and Retention Obligations.**

After the expiration of the Employment Obligation Term, the Company shall have no further obligation with respect to the Employment Obligation and shall not be liable for any of the payments described below.

The failure of the Company to satisfy the Employment Obligation can subject the Company to payments to the Agency. The Company shall be required to make payments if it fails to attain the Minimum Standard.

If the Company falls below the Minimum Standard, the Agency will notify the Company in writing of the Agency's intention to recapture Financial Assistance. The Company will have thirty (30) days to respond to the letter and may include a request to appear before the Agency. The Agency will determine, in its sole discretion, if a valid exemption exists and potentially reduce the remedies described below.

2. **Projects with less than Ten Years Employment Obligation Term.**

(a) **Shortfall Payments.**

- (1) If, during the first three (3) years of the Employment Obligation Term a Company fails to achieve the Minimum Standard, then the Company shall pay to the Agency an amount equal to (a) the Per Employee Amount multiplied by (b) the Shortfall and then multiplied by (c) 1.5.
- (2) If, after the first (3) years, of the Employment Obligation Term a Company fails to achieve the Minimum Standard, then the Company shall pay to the Agency an amount equal to (a) the Per Employee Amount multiplied by (b) the Shortfall.

(b) **Major Shortfall Payment.**

- (1) If a Company shall incur a Major Shortfall; then, the Company shall pay to the Agency as an additional one-time payment an amount as set forth in the schedule below (such payment shall be referred to as the "Major Shortfall Payment").

<b><u>Major Shortfall Occurs:</u></b>	<b><u>Percentage of Initial Benefit</u></b>
Year 1	100%
Year 2	80%
Year 3	60%
Year 4	40%
Any Subsequent Year	20%

- (2) Notwithstanding any of the foregoing, the Company shall not be liable for a Major Shortfall Payment unless the number of FTEs remains at less than 65% of the Employment Obligation at the expiration of a Cure Period. The Company shall have the opportunity at any time before the expiration of a Cure Period to provide additional information to the Agency regarding the Major Shortfall, and to request a waiver or amendment of this provision.

- (3) Notwithstanding any of the foregoing, a Major Shortfall shall not apply where the Shortfall is a result of a major casualty to or condemnation of the facility. In the event of such major casualty or condemnation, the Company shall have no obligation to pay the Major Shortfall Payment.
- (4) Qualification for a waiver of either (2) or (3) above shall be at the sole discretion of the Agency.

3. **Projects with Ten Years or Longer Employment Obligation Term.**

(a) **Shortfall Payments.**

- (1) If, during the first five (5) years of the Employment Obligation Term a Company fails to achieve the Minimum Standard, then the Company shall pay to the Agency an amount equal to (a) the Per Employee Amount multiplied by (b) the Shortfall and then multiplied by (c) 1.5.
- (2) If, after the first five (5) years of the Employment Obligation Term a Company fails to achieve the Minimum Standard, then the Company shall pay to the Agency an amount equal to (a) the Per Employee Amount multiplied by (b) the Shortfall.

(b) **Major Shortfall Payment.**

- (1) If a Company shall incur a Major Shortfall, then the Company shall pay to the Agency as an additional one-time payment an amount as set forth in the schedule below.

<b><u>Major Shortfall Occurs:</u></b>	<b><u>Percentage of Initial Benefit</u></b>
Year 1	100%
Year 2	90%
Year 3	80%
Year 4	70%
Year 5	60%
Year 6	50%
Year 7	45%
Year 8	40%
Year 9	35%
Year 10	30%

- (2) Notwithstanding any of the foregoing, the Company shall not be liable for a Major Shortfall Payment unless the number of FTEs remains at less than 65% of the Employment Obligation at the expiration of a Cure Period. The Company shall have the opportunity at any time before the expiration of a Cure Period to provide additional information to the Agency regarding the Major Shortfall, and to request a waiver or amendment of this provision.
- (3) Notwithstanding any of the foregoing, a Major Shortfall shall not apply where the Shortfall is as a result of a major casualty to or condemnation of the facility. In the event of such major casualty or condemnation, the Company shall have no obligation to pay the Major Shortfall Payment.

(4) Qualification for a waiver of either (2) or (3) above shall be at the sole discretion of the Agency.

4. **Shift of Employment.** If the Shortfall or Major Shortfall is as a result of the Company shifting employment away from Oneida County, then the Agency will require the value of the Benefit and the Initial Benefit utilized to date to be repaid, with interest (determined as the New York State legal interest rate).

5. **Mandatory Recapture.** The Agency is mandated to recapture New York State sales tax benefits where:

- a. The Project is not entitled to receive those benefits.
- b. The exemptions exceed the amount authorized, or are claimed for unauthorized property or services.
- c. The Company fails to use property or services in the manner required by the Leaseback Agreement.

6. **Return of Recaptured Funds.** If the Agency recaptures Initial Benefits or Benefits from a Company, the Agency shall return the recaptured funds promptly to the affected taxing jurisdiction, unless otherwise agreed to by the taxing jurisdiction, in accordance with the General Municipal Law.

**The Agency shall have the right to reduce any payment required under this Policy, in extraordinary circumstances, in its sole discretion.**

## Oneida County Industrial Development Agency

### Insurance Requirements Under Leaseback Agreement

#### Section 3.4 Insurance Required.

At all times throughout the Lease Term, including, when indicated herein, during the Construction Period, the Company shall, at its sole cost and expense, maintain or cause to be maintained (and cause the Sublessees to maintain, where appropriate) insurance of the following types of coverage and limits of liability with an insurance carrier qualified and admitted to do business in New York State. The Insurance carrier must have at least an A- (excellent) rating by A. M. Best. Company shall pay, as the same become due and payable, all premiums with respect thereto, including, but not necessarily limited to:

(a) **Property Insurance:** Insurance against loss or damage by fire, lightning and other casualties customarily insured against in an all risk policy with special form perils, such insurance to be in an amount not less than the full replacement value of the completed Improvements, exclusive of footings and foundations, as determined by a recognized appraiser or insurer selected by the Company. During the Construction Period, such policy shall be written in the so-called "Builder's Risk Completed Value Non-Reporting Form" and shall contain a provision granting the insured permission to complete and/or occupy.

(b) **Workers' Compensation & Employers Liability Insurance** and **Disability Benefits Insurance** and each other form of insurance that the Company or any permitted sublessee is required by law to provide, covering loss resulting from injury, sickness, disability or death of employees of the Company or any permitted sublessee who are located at or assigned to the Facility. Statutory New York limits shall apply to these policies. This coverage shall be in effect from and after the Completion Date or on such earlier date as any employees of the Company, any permitted sublessee, any contractor or subcontractor first occupy the Facility.

(c) **General Liability Insurance** protecting the Agency and the Company against loss or losses from liability imposed by law or assumed in any written contract (including the contractual liability assumed by the Company under Section 5.2 hereof) and arising from personal injury, including bodily injury or death, or damage to the property of others, caused by an accident or occurrence with a limit of liability of not less than \$1,000,000 per occurrence and \$2,000,000 annual aggregate. **Comprehensive Automobile Liability Insurance** including all owned, non-owned and hired autos with a limit of liability of not less than \$1,000,000 (combined single limit or equivalent for personal injury, including bodily injury or death, and property damage) protecting the Agency and the Company against any loss or liability or damage for personal injury, including bodily injury or death, or property damage, and **Umbrella Liability Insurance** of not less than \$5,000,000 per occurrence. This coverage shall also be in effect during the Construction Period.

(d) During the Construction Period (and for at least two years thereafter in the case of Products and Completed Operations as set forth below), the Company shall cause the general contractor to carry liability insurance of the type and providing the minimum limits set forth below:

(i) Workers' compensation & employer's liability and disability benefits insurance both with statutory limits in accordance with applicable law.

- (ii) Comprehensive general liability providing coverage for:
- Premises and Operations
  - Products and Completed Operations
  - Contractual Liability
  - Personal Injury Liability
  - Broad Form Property Damage  
(including completed operations)
  - Explosion Hazard
  - Collapse Hazard
  - Underground Property Damage Hazard

Such insurance shall have a limit of liability of not less than \$1,000,000 per occurrence and \$2,000,000 annual aggregate. The annual aggregate shall apply per project. The contractor's general liability policy shall include coverage for the contractor and any of the additional insureds for any operations performed on residential projects including single or multi-family housing, residential condominiums, residential apartments and assisted living facilities.

(iii) Comprehensive auto liability, including all owned, non-owned and hired autos, with a limit of liability of not less than \$1,000,000 (combined single limit for personal injury, including bodily injury or death, and property damage).

(iv) Umbrella Liability with limits of \$5,000,000 per occurrence and \$5,000,000 annual aggregate.

(e) A policy or policies of flood insurance in the maximum amount of flood insurance available with respect to the Facility under the Flood Disaster Protection Act of 1973, as amended, whichever is less. This requirement will be waived upon presentation of evidence satisfactory to the Agency that no portion of the Land is located within an area identified by the U.S. Department of Housing and Urban Development as having special flood hazards.

#### Section 3.5 Additional Provisions Respecting Insurance.

(a) All insurance required by Section 3.4 hereof shall be procured and maintained in financially sound and generally recognized responsible insurance companies selected by the entity required to procure the same and authorized to write such insurance in the State. Such insurance may be written with deductible amounts comparable to those on similar policies carried by other companies engaged in businesses similar in size, character and other respects to those in which the procuring entity is engaged. All policies evidencing the insurance required by Section 3.4 hereof shall provide for at least thirty (30) day's prior written notice of the restriction, cancellation or modification thereof to the Agency. The policies evidencing the insurance required by Section 3.4(c) hereof shall name the Agency as additional insured on a primary & non-contributory basis. All policies evidencing the insurance required by Sections 3.4(d)(ii) (iii) and (iv) shall name the Agency and Company as additional insured on a primary and non-contributory basis for the ongoing construction phase and for two years following completion during the completed operations phase. The policies under Section 3.4 (a) shall contain appropriate waivers of subrogation. The policies under Section 3.4 (b),(c),(d) shall contain waivers of subrogation in favor of the Agency and Company.



(b) All policies or certificates (or binders) of insurance required by Sections 3.4 hereof shall be submitted to the Agency on or before the Closing Date. Attached to the certificate of insurance shall be a copy of the additional insured endorsement from the Company's General Liability policy. The Company shall deliver to the Agency before the renewal date of each policy a certificate dated not earlier than the immediately preceding month reciting that there is in full force and effect, with a term covering at least the next succeeding calendar year, insurance of the types and in the amounts required by Section 3.4 hereof and complying with the additional requirements of Section 3.5(a) hereof. Prior to the expiration of each such policy, the Company shall furnish the Agency with evidence that such policy has been renewed or replaced or is no longer required by this Leaseback Agreement. The Company shall provide such further information with respect to the insurance coverage required by this Leaseback Agreement as the Agency may from time to time reasonably require.

Agency shall be named as additional insured as follows:

Oneida County Industrial Development Agency, ISAOA  
584 Phoenix Drive  
Rome, New York 13441

Anthony J. Picente Jr.  
County Executive

Shawna M. Papale  
Secretary/  
Executive Director

Jennifer Waters  
Assistant Secretary

ONEIDA COUNTY INDUSTRIAL  
DEVELOPMENT AGENCY

**OCIDA**



584 Phoenix Drive, Rome, New York 13441-4105  
(315) 338-0393, fax (315) 338-5694  
info@mvedge.org www.oneidacountyida.org

David C. Grow  
Chairman

L. Michael Fitzgerald  
Vice Chair

Mary Faith Messenger  
Treasurer

Ferris Betrus Jr.  
Kirk Hinman  
Eugene Quadraro  
Stephen Zogby

---

## ONEIDA COUNTY INDUSTRIAL DEVELOPMENT AGENCY UNIFORM TAX EXEMPTION POLICY

---

**Adopted by the Oneida County Industrial Development Agency on  
January 28, 1994, amended on December 21, 1998 and April 30, 2009**

The Oneida County Industrial Development Agency (the "Agency") has adopted the following uniform tax exemption policies. These policies will be used for all projects for which the Agency may provide financial assistance, including bond (taxable and/or tax exempt) issuances and straight lease transactions. Final determinations regarding the extent to which financial assistance, if any, will be granted are solely within the discretion of the Agency.

**I. Project Eligibility Criteria**

**(a) General Requirements**

The Agency considers the following general factors in determining whether a project is eligible for financial assistance:

- The nature of the proposed project (e.g., manufacturing, commercial, civic).
- The nature of the property before the project begins (e.g., vacant land, vacant buildings).
- The economic condition of the area at the time of the application.
- The extent to which a project will create or retain permanent, private sector jobs.
- The estimated value of tax exemptions to be provided.
- The impact of the project and the proposed tax exemptions on affected tax jurisdictions.
- The impact of the proposed project on existing and proposed businesses and economic development projects in the County.
- The amount of private sector investment generated or likely to be generated by the proposed project.
- The likelihood of accomplishing the proposed project in a timely fashion.
- The effect of the proposed project upon the environment.

- 
- The extent to which the proposed project will provide additional sources of revenue for municipalities and school districts in which the project is located.
  - The extent to which the proposed project will provide a benefit (economic or otherwise) not otherwise available within the County of Oneida.

**(b) Industrial and Manufacturing Projects**

(1) Industrial and manufacturing projects generally qualify for financial assistance, subject to the eligibility criteria set forth in Part I (a) of this Policy.

(2) Due to the nature of the work, companies performing back-office operations that are regional or national in nature and a majority of which operations support activities outside of Oneida County will qualify as industrial and manufacturing. Research and development facilities and distribution centers that locate in Oneida County may also qualify as industrial and manufacturing.

**(c) Retail Projects**

The Agency will provide financial assistance to retail facilities only in accordance with the restrictions contained in New York State General Municipal Law Section 862(2), and subject to the eligibility criteria set forth in Part I (a) of this Policy. The Agency will also consider the competitive impact of the project.

Retail projects are generally not eligible for Agency assistance, with the following exceptions:

(i) Retail businesses that primarily serve customers located in Oneida County are generally not eligible for financial assistance unless located in a "highly distressed area" as defined in General Municipal Law §854(18), which includes projects located in an economic development zone or Empire Zone (as defined in New York State statute or regulation), or the project meets one of the other requirements of this paragraph (c);

(ii) Retail projects operated by not-for-profit corporations may be eligible for financial assistance;

(iii) Retail projects may be eligible for financial assistance provided an appropriate market analysis demonstrates that a majority of the project's customers are expected to come from outside of Oneida County and the project will not directly compete with existing businesses located in Oneida County; and

(iv) Retail businesses that primarily provide a product or a service that is otherwise not reasonably available in Oneida County may be eligible for financial assistance.

**(d) Other Non-Industrial/Commercial Projects**

Non-industrial/commercial projects may qualify for financial assistance at the discretion of the Agency, based upon its evaluation of the eligibility requirements set forth in Part I (a) of this Policy. The Agency confirms the following specific policies:

(i) Mixed or Multiple-Use Projects qualify for financial assistance, only with respect to that portion of the project that is used for purposes that qualify for financial assistance under this Policy.

(ii) Housing projects are generally not eligible for benefits, unless they

(a) service the elderly, low-income, assisted living or other groups with special needs; *or*

(b) promote employment opportunities and prevent economic deterioration, as confirmed by an appropriate market analysis, and such a determination is made by the Agency based upon all of the relevant facts.

## II. Real Property Tax Abatements

If the Agency determines that a project will receive real property tax abatements, a Payment-In-Lieu-Of-Tax Agreement (the "PILOT") will be negotiated with each project owner (the "Company") and will substantially follow the following guidelines with final determinations to be made by the Agency.

(i) Real Property Acquired by Company as part of Project. If the Company is acquiring real property as part of the Agency project, then the Agency's real property tax exemption will be available with respect to all real property acquired by the Company as part of the project and improvements thereto.

(ii) Substantial Improvements to Existing Real Property Owned by Company. If the Company is making "Substantial Improvements" (as defined below) to existing real property owned by the Company, then the Agency's real property tax exemption will apply to both the existing real property and the improvements.

(iii) Non-Substantial Improvements to Existing Real Property. If the improvements to existing real property owned by the Company are not Substantial Improvements, then the Agency's tax exemption shall apply only to the increase in assessment resulting from improvements constructed or installed as part of the project and the Company shall pay PILOT payments equal to the full amount of taxes on the existing real property.

The term "Substantial Improvements" means the value of the improvements constructed or installed as part of the project equals at least 50% of the value of the real property prior to construction or installation of the improvements, as determined by an independent valuation acceptable to the Agency.

### (a) Industrial and Manufacturing Projects

The Company shall pay a percentage of the taxes that would otherwise be payable if the project was not tax exempt, to each taxing jurisdiction in which the project is located, as follows:

1. 33 1/3% of such taxes through the fifth (5th) year of the exemption;

2. 66 2/3% of such taxes from the sixth (6th) through tenth (10th) year of the exemption;
3. 100% of such taxes after the tenth (10th) year of the exemption.

**(b) Retail Projects**

The Company shall pay a percentage of the taxes that would otherwise be payable if the project was not tax exempt, to each taxing jurisdiction in which the project is located, as follows:

1. 50% of such taxes through the second (2nd) year of the exemption;
2. 75% of such taxes from the third (3rd) through the fifth (5th) year of the exemption;
3. 100% of such taxes after the fifth (5th) year of the exemption.

**(c) Other Non-Industrial/Commercial Projects**

The Company shall pay a percentage of the taxes that would otherwise be payable if the project was not tax exempt, to each taxing jurisdiction in which the project is located, as follows:

1. 50% of such taxes through the second (2nd) year of the exemption.
2. 75% of such taxes from the third (3rd) through fifth (5th) year of the exemption.
3. 100% of such taxes after the fifth (5th) year of the exemption.

The Agency reserves the right to deviate from the real property tax abatement policy on a case by case basis at its sole discretion.

**III. Sales Tax Exemptions**

If, based on the eligibility criteria described in Part I of this Policy, the Agency determines a project is eligible for financial assistance, the Agency's financial assistance will include exemption from sales and use tax for costs of constructing, renovating and equipping the project.

Sales and use tax exemption, when available, will be authorized for the duration of the acquisition, construction and equipping of the project as described in the application for financial assistance. The Agency shall deliver a sales tax exemption letter which will expire one (1) year from the date of the project inducement. If construction, renovation or equipping is not complete at the expiration of the original sales tax exemption letter, upon request by the Company, the sales tax exemption letter may be extended at the discretion of the Agency.

All Companies receiving sales and use tax exemption benefits will be required to supply the Agency with a list of all contractors and sub-contractors that have been authorized to use the sales tax exemption letter. This list will be appended to the sales tax exemption letter by the Agency.

---

The Company must keep a record of the usage of the sales tax exemption letter, and must supply the Agency with the total amount of sales and use tax exemptions claimed by the project for each calendar year. The Company must submit this report to the Agency by February 1st of each year, until the exempt period comes to a conclusion. The company shall also file all reports as may be required by applicable law, including Form ST-340 which shall be filed with the New York State Department of Taxation and Finance.

The Agency reserves the right to deviate from the sales tax exemption policy on a case by case basis at its sole discretion.

#### **IV. Mortgage Recording Tax Exemption**

If, based on the project eligibility criteria described in Part I of this Policy, the Agency determines a project is eligible for financial assistance, the Agency will provide an exemption from New York State mortgage recording tax for the financing of project costs.

The Agency reserves the right to deviate from the mortgage recording tax exemption policy on a case by case basis at its sole discretion.

#### **V. Recapture**

Agency financial assistance is granted based upon the Company's representation that the project will create and/or maintain the employment levels described in its application for financial assistance (the "Employment Obligation"). If a Company fails to achieve and/or maintain its Employment Obligation, it could result in recapture of all or a portion of tax benefits granted by the Agency.

#### **VI. Deviations**

Deviations from this Policy shall be infrequent. The Agency reserves the right, at its sole discretion, to deviate from this Policy on a case by case basis. The Agency will provide written notice to the chief executive officer of each affected tax jurisdiction of any deviation from this Policy and will comply with the deviation requirements of the General Municipal Law.

April 2, 2018

Oneida County Industrial Development Agency (OCIDA)  
Uniform Tax Exemption Policy  
Business Relocation Assistance  
(Mohawk Valley Health Systems Project)

Purpose:

- The preference for all businesses displaced by the Mohawk Valley Health System ("MVHS") Project is to have them remain inside the City of Utica. The OCIDA recognizes that this may not be possible for all those business and this policy is to provide financial assistance to help mitigate costs of relocation for "Eligible Businesses" that will be impacted by the MVHS project.
- In keeping with the broader purpose of OCIDA to promote, develop, encourage or assist in the acquiring, constructing, reconstructing, improving, maintaining, equipping and furnishing of facilities in Oneida County and thereby advance the job opportunities, health, general prosperity and economic welfare of the people of Oneida County, if an Eligible Business commits to invest in a Replacement Property (above relocation costs) and/or create additional jobs, OCIDA may be able to offer additional financial assistance to an Eligible Business under its Uniform Tax Exemption Policy.

Eligible Businesses:

- Must have operated a business in the "Project Zone" and had employees whose place of employment was in the Project Zone during each month of 2017. "Project Zone" refers to any real estate located within the perimeter shown on the attached map that the Eligible Business owned or leased (under a written lease agreement) for all of 2017.
- To be eligible for financial assistance, an Applicant must have received an offer letter from MVHS and entered into an agreement with MVHS for the sale of its property in furtherance of the MVHS project.
- Industrial, commercial, back-office businesses and certain qualifying retail businesses (retail businesses that are relocating to a "highly distressed area" qualify for financial assistance under Section 874 of the New York State General Municipal Law) are eligible.
- Final determination of eligibility under Article 18-A of the New York State General Municipal Law shall be made by the IDA.
- An Eligible Business must not have filed a challenge to the taking of its real estate by eminent domain as "Not in the Public Good."
- The Eligible Business must be in negotiation for, under contract to, or be within 90 days of having acquired a replacement facility (the "Replacement Property"). The Replacement Property must be located in Oneida County.

Application:





- Financial assistance is conditioned upon Applicant maintaining, at a minimum, for ten years in the Replacement Property, the number of FTE employees that the Applicant employed in the "Project Zone" in 2017.
- Applicants will be subject to the recapture policy established by the IDA.
- Reduced benefits will apply if applicant no longer exclusively occupies the Replacement Property.

Deviations:

- The IDA reserves the right, at its sole discretion, to deviate from this Policy on a case-by-case basis, and will grant financial assistance to match a commitment by an Eligible Business to make an investment into and/or create employment at the Replacement Property.
- The IDA will provide written notice to each affected tax jurisdiction of any deviation from this Policy and will comply with the deviation requirement of the General Municipal Law.
- In addition to the other deviation criteria described in the IDA's Uniform Tax Exemption Policy, the IDA will consider the following to determine when it is appropriate to deviate from this policy:
  - ❖ If the Applicant commits to not only retain, but also to create, a significant number of additional permanent, private employees (FTEs) as a result of acquiring the Replacement Property.
  - ❖ If the Applicant commits to make an investment into improving the Replacement Property that exceeds expenses of relocating to the Replacement Property.
  - ❖ Consideration will be given to limiting the Base Tax to an equivalent tax based on an assessment equalization of the arms-length purchase price of the Replacement Property.

Duration of Policy:

- Three years from the date of implementation.



**Legend**  
Site Location

Date: January 11, 2016  
Scale: As Shown

**Proposed Hospital Site Location**

1 inch = 120 feet  
0 60 120  
240 Feet



**ATTACHMENT  
TO OCIDA APPLICATION FOR FINANCIAL ASSISTANCE**

**Part I: Applicant Information**

**Business Description**

**5(a) Explain your project in detail.**

Location.

Central Utica Building, LLC ("CUB") proposes to construct an approximately 70,000-80,000 square foot medical office building (the "MOB") at 601 State Street (corner of State and Columbia Streets) on approximately 2.9 acres of land adjacent to, and within the footprint of the new Wynn Hospital of the Mohawk Valley Health System (the "Wynn Hospital"). CUB seeks to locate the MOB and appurtenant facilities including parking areas on the following four parcels located in Utica and adjacent to the Wynn Hospital 318.041-2-37, 318.041-2-38, 318.041-2-39 and 318.041-2-40. The MOB will be located on parcel 318.041-2-37 and parking necessary to support the MOB will be located on the remaining three parcels.

Parcels 318.041-2-37, 318.041-2-39 and 318.041-2-40 are owned by Mohawk Valley Health System ("MVHS") and will be ground-leased to CUB pursuant to a ground lease with a term of 99 years. To accommodate the MOB's parking requirements the property located at 411 Columbia Street, tax map number 318.041-2-38 (the "O'Brien Parcel") must be included in the MOB's property assemblage. Otherwise, the MOB project cannot go forward.

A copy of the concept plan showing the location of the MOB and parking areas is attached.

Principal Tenants. The principal tenants of the MOB and their proposed activities are as follows:

Central New York Cardiology, P.C.

Central New York Cardiology, P.C. ("CNYC") is the largest cardiology group in the region and provides general cardiology, interventional cardiology and electrophysiology services to the community drawing patients from within and outside Oneida County. CNYC cardiologists will perform interventional cardiology services at the Wynn Hospital and will take cardiology call and provide cardiology services to patients admitted to the Wynn Hospital. CNYC will occupy and build-out an approximately 20,000 square foot state-of-the-art medical office to include office space for 17 cardiologists and 11 advance practice providers. The build-out and equipping of the CNYC office is part of this Application. The office will also house sophisticated diagnostic testing capabilities including two nuclear cameras, five echocardiology labs and three vascular labs. CNYC further intends to acquire a cardiac PET scanner, which will be one of the few in the area.

CNYC has recently hired three cardiologists and support staff in anticipation of moving to a larger facility and is recruiting another cardiologist with a subspecialty of electrophysiology. The practice currently employs two electrophysiologists. There is a substantial need in the community for this subspecialty and recruiting a third electrophysiologist will significantly reduce patient wait times. CNYC's recent and planned hires are all based on the assumption that the practice will soon occupy a larger, more modern office with state-of-the-art diagnostic technologies.

CNYC currently occupies an approximately 18,000 square foot office, located on four fragmented floors in a building adjacent to St. Elizabeth's Hospital under a lease that will expire in May 2023. The

space is too small, outdated and will no longer be located next to the hospital at which CNYC provides cardiology services and takes cardiology call.

#### Mohawk Valley ASC, LLC

Mohawk Valley ASC, LLC, a for-profit joint venture comprised of MVHS and local physicians, will build-out and operate an approximately 18,000 square foot, six operating room, Article 28 licensed, Medicare certified multi-specialty ambulatory surgery center. Currently, many types of surgeries and procedures previously performed in a hospital in-patient setting are migrating from hospitals to ambulatory surgery centers which provide significant cost savings to patients and payers and provide enhanced patient satisfaction.

#### Mohawk Valley Health System

MVHS will locate its Cardiac and Thoracic Surgery Group, Advanced Endoscopy clinic, Neuro-Interventional Surgery and Comprehensive Stroke Group and Imaging Center in the MOB.

Other Users: The balance of the MOB will be leased to other medical practices whose physicians practice in, and need access to the hospital and complementary non-medical uses.

#### **Reasons for Project**

##### **6(a) Please explain in detail why you want to undertake this project.**

The principal tenants of the MOB—CNYC, a 30 provider cardiology medical group servicing Oneida and surrounding counties, a six OR Medicare-certified ambulatory surgery center owned by a local physician-hospital joint venture and new MVHS specialty medical clinics and ancillary services such as lab and diagnostic radiology—will significantly enhance and expand the delivery of health care services to the community. The location of the MOB adjacent to the Wynn Hospital is critical. By being located within the Wynn Hospital footprint the MOB will enable the development of a seamless and integrated health care delivery system among the hospital and providers located in the MOB thereby improving the quality and accessibility of health care services in the community.

In addition, there is not available ambulatory surgery center capacity in the area to accommodate the volumes and types of inpatient surgical procedures that should appropriately migrate to an ambulatory surgery center setting. Ambulatory surgical centers deliver high quality surgical services at a cost significantly lower (up to 60% less) than that charged by hospitals, providing savings to patients, insurers and taxpayers. Ambulatory surgery centers also provide efficiencies and are more patient-friendly and convenient for patients. Medicare and commercial payers are driving the migration of cases from the hospital to ambulatory surgery centers. In addition, and importantly, the ambulatory surgery center will provide services to the underserved populations of Oneida and surrounding counties.

#### **Part V: Facility (Legal Information)**

**9(a)** Applicant is negotiating a 99 year ground lease for Parcels 318.041-2-37, 318.041-2-39 and 318.041-2-40 which are owned by Mohawk Valley Health System. To accommodate the MOB's parking requirements the property located at 411 Columbia Street, tax map number 318.041-2-38 (the "O'Brien Parcel") must be included in the MOB's property assemblage. The Applicant has engaged an appraiser and will make an offer to purchase the O'Brien Parcel.

**Part V: Facility**

**9(f) Tenancies**

**Proposed MOB Tenants**

<i>Tenant</i>	<i>Approx. SF to be Occupied*</i>	<i>Business</i>
Central New York Cardiology, P.C.	20,200	Cardiology medical practice
Mohawk Valley ASC, LLC	17,595	Six OR multi-specialty Article 28 ambulatory surgery center
MVHS Cardiac and Thoracic Surgery Group	1,500	Cardiothoracic surgeons
MVHS Advanced Endoscopy Clinic	1,000	Endoscopic surgeons
MVHS Neuro-Interventional Surgery and Comprehensive Stroke Group	1,000	Brain surgery/stroke care
MVHS Imaging Center	9,870	Diagnostic radiology including CT, MRI and X-Ray
MVHS Outpatient Lab/Patient Service Center	600	Laboratory services
Dr. Qandah	2,500	Medical office
Dr. Welcons	2,500	Medical office
Medical practices (TBD)	5,000	Medical office
Coffee shop/ATM, etc	1,000	

\* This represents the actual size of the space—actual square footage. Rentable square footage will be approximately 30% greater. The sum of all rentable square footage will equal the size of the MOB.

**Part VII: Employment Information**

**11(b) Will the project preserve permanent, private sector jobs or increase the overall number of permanent private sector jobs in the State of New York?**

The project will do both. Modern health care is now acknowledged as a major economic driver for both small and large communities. Health systems are a prime source of both high technology and high paying professionals and remains a major growth industry.

CNYC has recently hired three cardiologists and support staff in anticipation of moving to a larger facility and is recruiting another cardiologist with a subspecialty of electrophysiology. The practice currently employs two electrophysiologists. There is a substantial need in the community for this subspecialty and recruiting a third electrophysiologist will significantly reduce patient wait times. CNYC's recent and planned hires are all based on the assumption that the practice will soon occupy a larger, more modern office with state-of-the-art diagnostic technologic.

Mohawk Valley ASC, LLC plans to create 9-10 FTE opportunities and will shift up to 23 FTEs from inpatient hospital ORs to the new ambulatory surgery facility. In the absence of the this surgery

center, cases traditionally performed on an in-patient basis may migrate to other lower cost settings in Oneida County or elsewhere putting these MVHS OR staff members' jobs at risk.

**From:** [Dave Quirello](#)  
**To:** [Shawna Papale](#)  
**Cc:** [Mark Kaucher](#)  
**Subject:** Re: Executed Application  
**Date:** Monday, November 15, 2021 8:55:55 AM

---

Shawna

Does 11 or 12 work for you?

Dave  
sent from my iPhone

On Nov 13, 2021, at 11:43 PM, Shawna Papale <[spapale@mvedge.org](mailto:spapale@mvedge.org)> wrote:

Save let us plan to chat Monday.

Shawna Papale  
Sent from my iPhone

On Nov 13, 2021, at 10:31 AM, Dave Quirello  
<[dquirello@cnycardiology.com](mailto:dquirello@cnycardiology.com)> wrote:

Shawna,

I would like to have a quick conversation on the average indirect and construction jobs as well as the calculation of benefits just so I have a better idea where these numbers derived from. Otherwise, yes I approve.

Thank you. Take care.

David Quirello, CMPE  
Chief Financial Officer  
[<image001.png>](#)

2211 Genesee Street  
Utica NY 13501  
Phone: (315) 733-7598 ext. 2236  
Fax: (315) 733-7694  
[dquirello@cnycardiology.com](mailto:dquirello@cnycardiology.com)

**From:** Shawna Papale [<mailto:spapale@mvedge.org>]  
**Sent:** Friday, November 12, 2021 1:47 PM

**Sent:** Friday, November 12, 2021 12:42 PM  
**To:** Shawna Papale <[spapale@myedge.org](mailto:spapale@myedge.org)>  
**Cc:** 'Bruce A. Smith' <[bsmith@ccblaw.com](mailto:bsmith@ccblaw.com)>  
**Subject:** Executed Application

Shawna,

Please find the executed application attached. The site and building concepts are embedded in the attachment. I will get it notarized on Monday and forward the original along with the \$1500 check.

Take care.

David Quirello, CMPE  
Chief Financial Officer  
<[image003.png](#)>

2211 Genesee Street  
Utica NY 13501  
Phone: (315) 733-7598 ext. 2236  
Fax: (315) 733-7694  
[dquirello@cnycardiology.com](mailto:dquirello@cnycardiology.com)

CAUTION: This email originated from outside of the organization. Do not click links or open attachments unless you recognize the sender and know the content is safe.

CAUTION: This email originated from outside of the organization. Do not click links or open attachments unless you recognize the sender and know the content is safe.

CAUTION: This email originated from outside of the organization. Do not click links or open attachments unless you recognize the sender and know the content is safe.



ONEIDA COUNTY INDUSTRIAL  
DEVELOPMENT AGENCY

**OCIDA**



---

## APPLICATION FOR FINANCIAL ASSISTANCE

**Oneida County Industrial Development Agency**

584 Phoenix Drive

Rome, New York 13441-1405

(315) 338-0393 telephone

(315) 338-5694 fax

Shawna M. Papale, Executive Director

spapale@mvedge.org

Please submit the signed and notarized completed application (Pages 1-25 ONLY), which must include any applicable addendum or supplemental information requested in the application, along with payment of a non-refundable \$500 Application Fee and a \$1,000 Commitment Fee (will be applied to final closing costs) to the Oneida County Industrial Development Agency, 584 Phoenix Drive, Rome NY 13441-1405, within 14 days prior to the OCIDA Board of Directors meeting at which you want the Application to be included on the Agenda. Wire transfer and ACH payments are acceptable but all related fees incurred by the Agency are payable by the Applicant. An electronic version of the application must accompany the original application via physical media or e-mail.

CENTRAL UTICA BUILDING

Project Name

Date of Submission

11/12/2021

**Important Notes to Applicant:**

Upon the submission of this application to the OCIDA, the application becomes a public document. Be advised that any action brought before the Agency is public information. All agendas for the OCIDA are issued publicly prior to the full agency meeting. **IF THERE IS INFORMATION SUBMITTED THAT THE APPLICANT BELIEVES IS PROPRIETARY, PLEASE IDENTIFY IT AS SUCH AND THAT INFORMATION WILL BE TREATED CONFIDENTIALLY TO THE EXTENT PERMITTED BY LAW.**

The information requested by this application is necessary to determine the eligibility of your project for OCIDA benefits. Please answer all questions and respond "Not Applicable", "NA", or "none" where appropriate. If you're response is an estimate, please indicate so. Attach additional sheets if more space is needed for a response. **All applications must include a completed and signed NYS SEQR form and Cost Benefit Analysis form (please consult with OCIDA) before the application is considered complete.**

By signing and submitting this Application, the Applicant acknowledges that it received a copy of the Uniform Tax Exemption Policy and the Oneida County IDA Penalty for Failure to Meet Employment Levels as adopted by the Agency and Agency Memorandums pertaining to the benefits of projects financed through the Agency.

A project financed through the Agency involves the preparation and execution of significant legal documents. Please consult with an attorney before signing any documents in connection with the proposed project. You will receive an engagement letter from the OCIDA legal counsel. You will be asked to sign the engagement letter acknowledging you will be responsible for all legal fees of OCIDA legal counsel and that you understand the process. Should you not close and legal services have been rendered by the OCIDA legal counsel, Applicant will be responsible for those costs.

If your project requires a public hearing, a representative of the applicant is required to be present. A date will be coordinated by the OCIDA legal counsel.

If you have any questions how to calculate the OCIDA's application fee please refer to the enclosed Memorandum to Companies -Sale Leaseback Transactions or contact the OCIDA.

Please submit the signed and notarized completed application along with payment of a non-refundable **\$500 Application Fee** and a **\$1,000 Commitment Fee** (will be applied to final closing costs) to the **Oneida County Industrial Development Agency, 584 Phoenix Drive, Rome NY 13441-1405, within 14 days prior to the OCIDA Board of Directors meeting at which you want the Application to be included on the Agenda.** Wire transfer and ACH payments are acceptable but all related fees incurred by the Agency are payable by the Applicant. An electronic version of the application must accompany the original application via physical media or e-mail.

**Part I: Applicant Information**

**Note:** In responding to the following questions, please keep in mind that the Applicant will be party to all of the documents and is the individual or if entity will be formed which will receive the actual financial assistance from the Agency.

**Applicant**

1(a) Applicant's Legal Name: Central Utica Building, LLC

1(b) Principal Address: 2211 Genesee Street  
Utica NY 13501

1(c) Telephone/Facsimile Numbers: (315) 733-7598

1(d) Email Address: dquirello@cnycardiology.com

1(e) Federal Identification Number: 86-3656655

1(f) Contact Person: David Quirello

1(g) Is the Applicant a

- Corporation: If Yes, Public  Private   
If public, on which exchange is it listed?
- Subchapter S
- Sole Proprietorship
- General Partnership
- Limited Partnership
- Limited Liability Corporation/Partnership
- Single-Member LLC (name and EIN below):

Name: \_\_\_\_\_  
EIN #: \_\_\_\_\_

- DISC
- Other(specify) \_\_\_\_\_

1(h) State of Organization (if applicable) New York

**Applicant's Stockholders, Members, Directors and Officers, Partners**

2(a) Provide the following information with respect to parties with 15% or more in equity holdings:

<u>Name</u>	<u>Address</u>	<u>Percentage of Ownership</u>
<p>Central Ulcer Bowling LLC (CUB) is owned as follows</p> <p>CNYC Realty, LLC - 30%</p> <p>5DOCS, LLC - 70%</p> <p>The owners of CNYC Realty, LLC and 5DOCS, LLC are the shareholders of Central New York Cardiology, P.C. as follows</p> <p>Arnon R. Patel, M.D.</p> <p>Michael W. Kolbman, M.D.</p> <p>Poojith K. Varma, M.D.</p> <p>Peter S. Holvett, M.D.</p> <p>Hugh C. MacLennan, M.D.</p> <p>Derry A. Lavin, M.D.</p> <p>Darius J. Mohamadi, M.D.</p> <p>Daniel E. Barr, M.D.</p> <p>Traci T. Markwood, M.D.</p> <p>Michael A. Sussow, M.D.</p>		

2(b) Is the Applicant, or any of the individuals listed in 2(a) above, related directly or indirectly to any other entity by more than 50% common ownership? **If Yes**, indicate name of such entity and the relationship.  Yes  No

The members of CNYC Realty, LLC and 5DOCS, LLC are shareholders of Central New York Cardiology, P.C.

The shareholders of Central New York Cardiology, P.C. are listed in 2(a) above.

2(c) Is the Applicant affiliated with any other entity, directly or indirectly, other than as listed in the response to 2(a) above? **If Yes**, please indicate name and relationship of such other entity and the address thereof:  Yes  No

**Applicant's Counsel and Accountant**

**3(a) Applicant's Attorney**

Name/Title: Bruce Smith  
Firm: Cohen Compagni Beckman Appler & Knoll, PLLC  
Address: 507 Plum Street, Suite 310  
Syracuse NY 13204  
Telephone/Fax: (315) 477-6291  
Email: bsmith@ccblaw.com

**3(b) Applicant's Accountant**

Name/Title: Allison Greco  
Firm: D'Arcangelo & Co., LLP  
Address: 120 Lomond Court  
Utica NY 13502  
Telephone/Fax: (315) 735-5216  
Email: agreco@darcangelo-cny.com

**Business Description**

**4(a)** Describe the nature of your business and principal products and/or services. Attach additional sheets if necessary.

Central Utica Building, LLC proposes to construct an approximately 70-80,000 square foot state-of-the-art medical office building (the "MOB") adjacent to the new Wynn Hospital of the Mohawk Valley Health System. As discussed in 5(a) below, the MOB will be occupied primarily by Central New York Cardiology, P.C. (~20-22,000 sf), Mohawk Valley ASC, LLC, a for-profit physician-hospital joint venture owned by MVHS and local physicians that will construct and operate an Article 28 multi-specialty ambulatory surgery center (~18,000 sf) and Mohawk Valley Health System ("MVHS") (~14-17,000 sf) for various specialty medical clinics and other services.

**Part II: Project Information**

**5(a)** Explain your project in detail. This description should include explanation of all activities which will occur due to this project. Attach additional sheets if necessary.

See Attachment

**Reasons for Project**

**6(a)** Please explain in detail why you want to undertake this project.

See Attachment

**6(b)** Why are you requesting the involvement of the Agency in your project?

The sales tax and mortgage recording tax benefits provided by the Agency are an important part of the financing plan for the MOB and for CNYC's tenant improvement build out and its acquisition of FF&E, including medical equipment.

Acquiring the parcel of property located at 411 Columbia St./Site Tax Map 318.041-2-38 (the "O'Brien Parcel") to provide patient parking for the MOB is critical. Without this property it will be impractical if not impossible to construct the MOB as proposed. If CUB is unable to acquire the O'Brien Parcel from the property owner CUB will request that the Agency acquire the property through eminent domain.

6(c) Please confirm by checking the box below, if there is the likelihood that the Project would not be undertaken **BUT FOR** the Financial Assistance provided by the Agency.

Yes     No

If the Project could be undertaken without Financial Assistance provided by the Agency, ("**No**" is checked above) then provide a statement in the space provided below indicating why the Agency should approve the requested assistance:

In addition to the need for the requested financial assistance, this project should be undertaken by the Agency because (i) the services provided by the MOB's tenants are needed in the community; (ii) the location of the MOB--and the health care services provided by its tenants--will allow for the development of an integrated health care delivery system among the Wynn Hospital and physician providers improving the quality and accessibility of health care services in the community.

How will the Applicant's plans be affected or scaled back if Agency approval is not granted?

It is likely that the MOB would not be built in a location in downtown Utica adjacent to the Wynn Hospital, a location preferred by the Wynn Hospital, the MOB's proposed tenants and the patient populations of both.

6(d) Is the proposed project reasonably necessary to discourage the Applicant from removing such other plant or facility to a location outside the State of New York?

Yes     No    If Yes, please explain briefly.

6(e) Will financing by the Agency result in the removal or abandonment of a plant or other facility of the applicant or any related entity presently located in another area of New York State?

Yes     No

If Yes, is the proposed project reasonably necessary to preserve the competitive position of the Applicant in its respective industry?     Yes     No

If Yes, please provide a statement and evidence supporting the same. Include the name of all taxing jurisdictions in which the abandoned facility or plant lies, and whether Applicant has had any discussions with said taxing jurisdictions regarding the abandonment. Please provide as much detail as possible.

6(f) Has the Applicant or any related entity previously secured financial assistance in Oneida County (whether through the Agency, the Empire State Development Corporation, or any other entity)?  Yes  No

**If Yes**, please explain (indicate date of benefit, location of facility and outstanding balance).

6(g) Has the Applicant or any related entity secured financial assistance anywhere within the United States within the last 90 days or does the Applicant or any related entity anticipate receiving financial assistance within the next 90 days?  Yes  No

**If Yes**, please explain.

6(h) Check all categories best describing the type of project for all end users at project site (you may check more than one; if checking more than one indicate percentage of square footage the use represents):

Please provide percentage of sq. footage for each use (if more than one category):

- |                                     |                                |                      |   |
|-------------------------------------|--------------------------------|----------------------|---|
| <input type="checkbox"/>            | Manufacturing                  | <input type="text"/> | % |
| <input type="checkbox"/>            | Industrial Assembly or Service | <input type="text"/> | % |
| <input type="checkbox"/>            | Back office operations         | <input type="text"/> | % |
| <input type="checkbox"/>            | Research and Development       | <input type="text"/> | % |
| <input type="checkbox"/>            | Technology/Cybersecurity       | <input type="text"/> | % |
| <input type="checkbox"/>            | Warehousing                    | <input type="text"/> | % |
| <input checked="" type="checkbox"/> | Commercial or Recreational     | 40                   | % |
| <input checked="" type="checkbox"/> | Retail                         | 60                   | % |

Addendum Required

- |                          |   |                      |   |
|--------------------------|---|----------------------|---|
| <input type="checkbox"/> | Residential housing (specify) _____                                 | <input type="text"/> | % |
| <input type="checkbox"/> | Pollution Control (specify) _____                                   | <input type="text"/> | % |
| <input type="checkbox"/> | Environmental (e.g., Brownfield) (specify) _____                    | <input type="text"/> | % |
| Addendum Required        | <input type="checkbox"/> Other (specify ie; renewable energy) _____ | <input type="text"/> | % |



6(i) Check all categories best describing the **scope of the project**:

- Acquisition of land
- Acquisition of existing building
- Renovations to existing building
- Construction of addition to existing building
- Demolition of existing building or part of building
- Construction of a new building
- Acquisition of machinery and/or equipment
- Installation of machinery and/or equipment
- Other (specify) \_\_\_\_\_

6(j) Please indicate the financial assistance you are requesting of the Agency, and provide the estimated value of said assistance. Attach a sheet labeled Annual PILOT that shows the annual utilization of the Real Property Tax Abatement by year and by taxing jurisdiction (PLEASE CONSULT WITH IDA STAFF ON PILOT CALCULATIONS).

<u>Assistance Requested</u>	<u>Estimated Values</u>
<input type="checkbox"/> Real Property Tax Abatement (value of PILOT savings)	\$ _____
<input checked="" type="checkbox"/> Mortgage Tax Exemption (.75%) <u>128,138</u>	
\$ Amount of mortgage: <u>\$17,085,000</u>	
<input checked="" type="checkbox"/> Sales and Use Tax Exemption ** (8.75%) <u>\$1,820,000</u>	(Not available for solar)
Value of goods/services to be exempted from sales tax: <u>\$20,800,000</u>	
<input type="checkbox"/> Issuance by the Agency of Tax Exempt Bonds(bond dollar value)\$_____	

**TOTAL EXEMPTION ASSISTANCE REQUESTED: \$ 1,948,138**

Is the financial assistance requested by the Applicant consistent with the IDA's Uniform Tax Exemption Policy?  Yes  No

**If No**, please provide a written statement describing the financial assistance being requested and detailing the reasons the IDA should consider deviating from its Policy.

\*\* Note that the estimate provided above will be provided to the New York State Department of Taxation and Finance. The Applicant acknowledges that the transaction documents will include a covenant by the Applicant that the estimate, above, represents the maximum amount of sales and use tax benefit currently authorized by the Agency with respect to this Application. The Agency may utilize the estimate, above, as well as the proposed total Project Costs as contained within this Application, to determine the Financial Assistance that will be offered. It is the responsibility of the applicant to inform the IDA within 10 days if the project amount changes.

**Part III: Facility Information**

**Attach copies of the most recent real property tax bills. Include copies for all taxing jurisdictions for the site/ facility that IDA assistance is being sought.**

**Facility (Physical Information) If multiple locations please provide information on all.**

7(a) Street Address of Facility:

601 State Street (Corner of State & Columbia)

7(b) City, Town and/or Village (list ALL incorporated municipalities):

Utica, NY

7(c) School District:

Utica City School District

7(d) For what purpose was the facility site most recently used (i.e., light manufacturing, heavy manufacturing, assembly, etc.)?

Wholesale, Service Sector

7(e) Zoning Classification of location of the project:

Central Business District/Commercial

7(f) Please describe in detail the facility to be acquired, constructed or renovated (including number of buildings, square footage, number of floors, type of construction,) and attach plot plans, photos or renderings, if available. If there are infrastructure improvements (water, sewer, gas, electrical, etc.) please provide details along with who will carry out those improvements and who will fund them. ***Please be as specific as possible.***

See answer to 5(a) on the Attachment.

All new building utilities will be connected to the existing infrastructure ( MVWA, National Grid, Spectrum, Verizon City Storm, City/County sanitary sewers) that reside on both Columbia & State Streets and will be included in the project.

7(g) Has construction or renovation commenced?  Yes  No

If Yes, please describe the work in detail that has been undertaken to date, including the date of commencement.

If No, indicate the estimated dates of commencement and completion:

Construction Commencement: 3/2022

Construction completion: 7/2023

7(h) Will the construction or operation of the facility or any activity which will occur at the site require any local ordinance or variance to be obtained or require a permit or prior approval of any state or federal agency or body (other than normal occupancy and/or construction permits)?

Yes  No

If Yes please describe.

The physician-hospital ambulatory surgery center joint venture will require certificate of need approval from the New York State Department of Health.

Has the Project received site plan approval from the Planning Department?

Yes  No  N/A

If Yes, please provide the Agency with a copy of the planning department approval along with the related State Environmental Quality Review (SEQR) determination. If no, please provide the status of approval:

This was included in the MVHS/Wynn Hospital site plan approval.

7(i) Will the project have a significant effect on the environment?  Yes  No

**Important: please attach and sign Part 1 of either the the long or short Environmental Assessment Form to this Application.**

7(j) What is the useful life of the facility? 100 years

7(k) Is the site in a former Empire Zone?  Yes  No Utica Empire Zone

If Yes, which Empire Zone: \_\_\_\_\_  
Is project located in a Federal HUB Zone or distressed area:  Yes  No  
Provide detail.

Census Tract 264

ALL APPLICANTS MUST ANSWER PART IV-8(a)

**Part IV: Retail Project Questionnaire**

To ensure compliance with Section 862 of the New York General Municipal Law, the Agency requires additional information if the proposed Project is one where customers personally visit the Project site to undertake either a retail sale transaction or to purchase services.

**8(a).** Will any portion of the project (including that portion of the cost to be financed from equity or other sources) consist of facilities or property that are or will be primarily used in making sales of goods or services to customers who personally visit the project site?

Required  Yes or  No If the answer is YES, please continue below.  
If the answer is NO, proceed to Section Part V - Facility (Legal Info)

For purposes of Question A, the term "retail sales" means (i) sales by a registered vendor under Article 28 of the Tax Law of the State of New York (the "Tax Law") primarily engaged in the retail sale of tangible personal property (as defined in Section 1101(b)(4)(i) of the Tax Law), or (ii) sales of a service to customers who personally visit the Project.

**8(b).** What percentage of the cost of the Project will be expended on such facilities or property primarily used in making sales of goods or services to customers who personally visit the project? 60.00 %. **If the answer is less than 33% do not complete the remainder of this retail determination page and proceed to next section, Part V Facility (Pg 13)**

\* **If the answer to A above is Yes AND the answer to B above is greater than 33.33%, indicate which of the following questions below apply to the project:**

1. Will the project be operated by a not-for-profit corporation  Yes  No

2. Is the Project location or facility likely to attract a significant number of visitors from outside Oneida County?

Yes  No

**If yes,** please provide a third party market analysis or other documentation supporting your response.

3. Is the predominant purpose of the project to make available goods or services which would not, but for the project, be reasonably accessible to the residents of the municipality within which the proposed project would be located because of a lack of reasonably accessible retail trade facilities offering such goods or services?

Yes  No

**If yes,** please provide a third party market analysis that demonstrates that a majority of the project's customers are expected to come from outside of Oneida County and the project will not directly compete with existing businesses located in Oneida County.

**Part V: Facility (Legal Information)**

**9(a)** With respect to the **present owner** of the land or facility, please give the following information and provide a brief statement regarding the status of the acquisition.

*(Note: the present owner is not necessarily the user of the facility, but that party which holds legal title to the facility.)*

Legal Name: Mohawk Valley Health System  
Address: \_\_\_\_\_  
Telephone: \_\_\_\_\_  
Balance of Mortgage: N/A  
Holder of Mortgage: N/A

If the Applicant is not the present owner of the facility, please attach any written agreements and contracts concerning the acquisition of the real property and/or equipment.

**See Attachment**

**9(b)** Is there a legal relationship, directly or indirectly, by virtue of common control or through related persons, between the Applicant and the present owner of the facility?  
 Yes  No. If Yes, please explain.

\_\_\_\_\_

**9(c)** Will a related real estate holding company, partnership or other entity, be involved in the ownership structure of the transaction?  
 Yes  No. If Yes, please explain.

CUB will acquire the property by ground lease or purchase, construct the MOB and lease space within the MOB.

**9(d)** Will the title owner of the facility/property also be the user of the facility?  
 Yes  No If Yes, please explain.

\_\_\_\_\_

9(e) Is the Applicant currently a tenant in the facility?  Yes  No

9(f) Are you planning to use the entire proposed facility?  
 Yes  No

If **No**, please give the following information with respect to tenant(s) which will remain in the facility after the completion of the project, including the square footage the Applicant will occupy:

Name of Tenant	Floors Occupied	Sq. Ft. Occupied	Nature of Business
See Attachment			

9(g) Are any of the tenants related to the owner of the facility?  
 Yes  No **If Yes**, please explain.

Central New York Cardiology, P.C. is an affiliate of CUB.

9(h) Will there be any other users utilizing the facility?

Yes  No

If **Yes**, please explain. Provide detail of the contractual arrangement including any financial exchange for the use of the site or property.

All tenants of the building will be signing 10-30 year leases. No leases have been signed.

#### Part VI: Equipment

10(a) List the principal items or categories of equipment to be acquired as part of the project. If you are requesting sales tax exemption it is important to be as detailed as possible. (If a complete list is not available at time of application, as soon as one is available but prior to final authorizing resolution, please submit a detailed inventory of said equipment to be covered.) Attach a sheet if needed.

Medical equipment, computer equipment, etc.

10(b) Please provide a brief description of any equipment which has already been purchased or ordered, attach all invoices and purchase orders, list amounts paid and dates of expected delivery. Attach a sheet if needed.

No equipment has been purchased or ordered.

10(c) What is the useful life of the equipment? 7-10 years years

**Part VII: Employment Information**

"FTE" shall mean a full time employee that has a minimum of thirty-five (35) scheduled hours per week, or any combination of two or more part-time employees that work a minimum of fifteen (15) scheduled hours per week, when combined together, constitute the equivalent of a minimum of thirty-five (35) scheduled hours per week, and whose workplace location is the project facility. For this purpose an employee shall include a leased employee regularly retained by the company.

**11(a)** Estimate how many construction jobs will be created or retained as a result of this project.

100

**11(b)** Will the project preserve permanent, private sector jobs or increase the overall number of permanent, private sector jobs in the State of New York?

Yes     No    **If Yes**, explain below.

See Attachment

**11(c)** Have you experienced any employment changes (+ or -) in the last three (3) years?

Yes     No    **If Yes**, explain below.

**11(d)** Job Information related to project \*\*\*

Estimate below how many jobs will be created and retained as a result of this project, if OCIDA assistance is granted. **PLEASE MAKE SURE TOTAL PART-TIME EMPLOYEES ARE TURNED INTO FULL-TIME EQUIVALENTS (FTE) for Line B. - See Pg. 17.**

Number of Jobs BEFORE Project	Location 1	Location 2	Location 3	Location 4	Location 5	
Address in NYS	CNYC 2211 Genesee St Utica NY	St. Elizabeth Hosp. and St. Luke's Hospital				<b>Total</b>
Full-Time Company	116	23				139
Full-Time Independent Contractors						
Full-Time Leased						
<b>A. Total Full-Time BEFORE</b>	<b>116</b>	<b>23</b>				<b>139</b>
Part-Time Company	15					15
Part-Time Independent Contractors	5					5
Part-Time Leased						
<b>B. Total FTE Part-Timers BEFORE</b>	<b>7.5</b>					<b>7.5</b>
<b>C. Total FTE BEFORE*</b>	<b>123.5</b>	<b>23</b>				<b>146.5</b>

\*For Total FTE BEFORE add full-time employees (line A) plus part-time employees that have been converted to FTE (line B)

Number of Jobs AFTER Project (within 3 years of project completion)	Location 1 CNYC MOB	Location 2 ASC MOB	Location 3	Location 4	Location 5	Total
Full-time Company	121	32				153
Full-Time Independent Contractors						
Full-Time Leased						
<b>A. Total Full-Time AFTER</b>	<b>121</b>	<b>32</b>				<b>153</b>
Part-Time Company	16					16
Part-Time Independent Contractors	5					5
Part-Time Leased						
<b>B. Total FTE Part-Timers AFTER</b>	<b>7.9</b>					<b>7.9</b>
<b>C. Total FTE AFTER *</b>	<b>128.9</b>	<b>32</b>				<b>160.9</b>

*For Total FTE AFTER add full-time employees (line A) plus part-time employees that have been converted to FTE (line B).*

Estimate the number of residents from the Labor Market Area** in which the Project is located that will fill the jobs created within three years of project completion	Location 1	Location 2	Location 3	Location 4	Location 5	Total
<b>A. Full-Time</b>	<b>4</b>	<b>8</b>				<b>12</b>
<b>B. FTE Part-Timers</b>						<b>0</b>
<b>C. Total AFTER</b>	<b>4</b>	<b>8</b>				<b>12</b>

\*\* Labor Market Area includes Oneida, Lewis, Herkimer, and Madison Counties

Provide Any Notes To Job Information Below

As indicated above CNYC Cardiology has recruited 3 physicians to the region in August of 2021 as part of the strategic growth. Due to that fact the practice anticipates hiring 3 LPN's and an Echocardiograph Technician to keep up with the demand. Just the same we have begun to look for another cardiac physician with a subspeciality of Electrophysiology. Currently the practice employees two of these sub specialist who are in very high demand and patients sometimes have to wait weeks or longer for a consultation.

The ASC will create 9-10 new positions including 2-3 management positions

Recruitment outside of the Labor Market Area will include physician and possibly C level positions.



SALARY AND BENEFITS	Retained Jobs		Created Jobs	
	Average Annual Salary per employee	Average Fringe Benefits (as a percentage of wages)	Average Annual Salary per employee	Average Fringe Benefits (as a percentage of wages)
Management	\$ 117,000	26 %	\$ 96,000	28 %
Administrative	\$ 39,111	31 %	\$ 55,120	31 %
MVHS/ASC Management	\$	%	\$ 155,772	25 %
MVHS/ASC Administrative	\$ 99,672	25 %	\$ 57,227	25 %
Physicians / Advanced Providers	\$ 496,000	15 %	\$ 425,000	15 %
Overall Weighted Average	\$ 130,795	24 %	\$ 96,975	25 %

\*\*\* By statute, Agency staff must project the number of Full-Time Jobs that would be retained and created if the request for Financial Assistance is granted. "FTE" shall mean a full time employee that has a minimum of thirty-five (35) scheduled hours per week, or any combination of two or more part-time employees that work a minimum of fifteen (15) scheduled hours per week, when combined together, constitute the equivalent of a minimum of thirty-five (35) scheduled hours per week, and whose workplace location is the project facility. For this purpose an employee shall include a leased employee regularly retained by the company.

11(e) Please list NAICS codes for the jobs affiliated with this project:

621111  
621493  
621512  
621511

**Part VIII: Estimated Project Cost and Financing**

**12(a)** List the costs necessary for preparing the facility.

LAND Acquisition	\$	750,000 (Subject to adjustment)
Existing Building(s) ACQUISITION	\$	
Existing Building(s) RENOVATION	\$	
NEW Building(s) CONSTRUCTION	\$	30,868,891
Site preparation/parking lot construction	\$	1,611,800
Machinery & Equipment that is TAXABLE	\$	6,300,000
Machinery & Equipment that is TAX-EXEMPT	\$	
Furniture & Fixtures	\$	
Installation costs	\$	
Architectural & Engineering	\$	735,184
Legal Fees (applicant, IDA, bank, other counsel)	\$	100,000 (Subject to adjustment)
Financial (all costs related to project financing) *	\$	642,954
Permits (describe below)	\$	140,000
Other (describe below) ie: solar decommissioning expense)	\$	1,080,000

Other:	Cost:	Subtotal \$
1. Owner's Representative	\$ 400,000	Agency Fee <sup>1</sup> \$ 130,572 <hr/> <b>Total Project Cost \$ 42,359,401</b>
2. Mortgage Broker Fee	\$ 170,000	
3. Owner's Builders Risk & Insurance	\$ 56,000	
4. Building Taxes During Construction	\$ 36,000	
5. Soft Cost Contingency/Leasing Cont	\$ 290,000	
6. Miscellaneous Fees -	\$128,000	

\* **Bank fees, title insurance, appraisals, environmental reviews, etc.**

<sup>1</sup> **See Attached Fee Schedule (Page 24) for Agency Fee amount to be placed on this line.**

**Permit/Other Information**

Building Permit fees \$7/per 1,000 based on 20MM for the core & shell

**12(b)** Has the Applicant contacted any bank, financial institution or private investor with respect to financing the proposed project?  Yes  No **If Yes**, please provide details below.

Broker Agreement with Axiom Capital who is responsible for obtaining project financing for core and shell.  
 Principal: Chuck Cronin 1.518.366.4000  
 cmc@axiom-capital.com

**12(c)** Has the Applicant received a commitment letter for said financing? **If Yes**, please provide a copy along with this application.  Yes  No

**12(d) Sources of Funds for Project Costs**

Bank Financing: ----- \$ 29,350,000

Equity (excluding equity that is attributed to grants/tax credits) -- \$ 13,015,000

Tax Exempt Bond Issuance (if applicable) ----- \$ \_\_\_\_\_

Taxable Bond Issuance (if applicable) ----- \$ \_\_\_\_\_

Public Sources (Include sum total of all state and federal tax credits and grants) Break out individually below.----- \$ \_\_\_\_\_

Identify each Public state and federal grant/credit:

Comments:

Source	<input type="text"/>	\$	<input type="text"/>
Source	<input type="text"/>	\$	<input type="text"/>
Source	<input type="text"/>	\$	<input type="text"/>
Source	<input type="text"/>	\$	<input type="text"/>

CUB has made CFA application to NY Regional Economic Development Councils dated September 30, 2021. We were notified that we appear eligible to participate in the Commercial New Construction Program and persuing. Additionally will seek out new market credits.

**Total Sources of Funds for Project Costs:** \$ 42,365,000

**Part IX: Real Estate Taxes**

13(a) For each tax parcel which comprises the facility, and for which assistance is being sought, please provide the following information using figures from the most recent tax year. If an increase in the assessment is anticipated due to the proposed project, please indicate the new estimated assessment amount in the **POST- PROJECT** column. Attach copies of the most recent tax bills for all jurisdictions.

Tax Map Parcel #	Current Land Assessment	Current Building Assessment	Current Total Assessment	Current Total Taxes Amount (\$)	Estimated Post-Project Assessment
318.041-2-37					
318.041-2-38					
318.041-2-39					
318.041-2-40					

13(b) Will the entirety of each tax parcel be subject to the PILOT?  YES  NO

13(c) If the entirety of each parcel will not be subject to the PILOT, will the municipality require a subdivision?  YES  NO

\*If a subdivision is required, it is the responsibility of the Applicant to complete subdivision approval prior to commencement of the PILOT Agreement, and to provide the Agency with the tax parcel number(s) assigned.

13(d) Address of Receiver of Town and/or Village Taxes (include all jurisdictions):

1 Kennedy Plaza

Utica, NY 13502

13(e) Address of Receiver of School Taxes:

Utica City School District

13(f) Has the current property owner or user been granted an Ag-District exemption on the tax map parcel anytime during the past 4 years?

Yes  No

If Yes explain below.

13(g) Please consult with Agency staff to complete a Cost/Benefit Analysis form to attach to this Application.

Use space below for additional information

## NYS SEQRA Environmental Review

ALL SEQRA DOCUMENTATION CAN BE ACCESSED AT

<http://www.cityofutica.com/departments/urban-and-economic-development/planning/mvhs-seqra/index>

- The applicant must complete, sign and return to the IDA either the Short Form Environmental Assessment Form (SEAF) or the Full Environmental Assessment Form (FEAF). See the NYS DEC website for the most current versions of these documents.

<https://www.dec.ny.gov/permits/6191.html>

- To determine which EAF form is appropriate for the project, the applicant should consult with its engineer or legal counsel.
- It is the IDA's strong preference that the municipality that governs the jurisdiction where the project is located (e.g., a Planning Board, Zoning Board or other supervisory board) serve as lead agency for the SEQR review.
- In limited cases, the IDA will act as lead agency, but it may lead to additional cost to the applicant if a review is required to make a determination of environmental impact.
- If another public body is serving as lead agency for the SEQR review the applicant should provide the IDA with a signed Part 2 (and Part 3 if using the Long Form) and any minutes of meetings that detail the lead agency's determination.
- The IDA cannot grant any financial assistance until the SEQR review process is complete.

## **Agency Fee Schedule**

Commitment Fee: \$1,000 – due following the initial inducement but prior to scheduling of the public hearing; this amount is non-refundable if the applicant fails to close on the project before the IDA. Upon closing with the IDA this amount is applied to the closing fees.

Bond Fees:            ½ of 1% of total bond amount

IDA Agency Fee: PILOT, Mortgage Recording Exemption, Sales Tax Exemption:

- o Up to a \$1.0 Million project - \$5,000
- o Above \$1.0 Million project up to \$10.0 Million project – ½ of 1% of total project cost.
- o Above \$10.0 Million project – ½ of 1% of total project cost up to \$10.0 Million plus incremental increase of ¼ of 1% of total project above \$10.0 Million.
- o Any previously induced solar or renewable energy projects that have not yet proceeded to a final authorizing resolution, and are asking for an increase in benefits, will be subject to an Agency fee of one and one-half times the Agency's normal fee.

Transaction Counsel/Agency Counsel fee:

Set by Bond/Transaction Counsel based upon the nature and complexity of the transaction. This applies to bond and non-bond transactions (leasebacks, sale-leasebacks, etc).

Transaction Counsel/Agency Counsel fees for bond transactions typically will not exceed 2% of the bond amount or project costs. Transaction Counsel/Agency Counsel fees for a sale-leaseback/lease-leaseback transaction are typically \$8,500 to \$10,000 if no commercial financing is involved or \$10,000 to \$12,000 if commercial financing is involved. You will receive an engagement letter with a quote based upon the scope of your project.

Annual Fee:

For the term in which the property remains in the IDA's name, an annual lease payment is due in the amount of \$750. The first payment is due at closing and subsequent payments are due each January 1. For annual fees not paid and delinquent, a late charge of \$50 per month will be levied until such time the fee plus late charges are paid.

Other fees:

If Applicant requests the IDA enter into subsequent transactions following closing (i.e., a facility refinance), the IDA will charge a closing fee equal to 1/8 of one percent of the total reissuance, redemption, new or revised mortgage, refinancing, spreading agreement or other transaction with a minimum payment due of \$500. Applicant will also be responsible to pay any legal fees and any bank or financial institution fees the IDA incurs in connection with said transaction, throughout the term of the Agency's involvement with the facility.

## REPRESENTATIONS AND CERTIFICATION BY APPLICANT

The undersigned requests that this Application be submitted for review to the Oneida County Industrial Development Agency (the "Agency") and its Board of Directors.

Approval of the Application can be granted solely by this Agency's Board of Directors. The undersigned acknowledges that Applicant shall be responsible for all costs incurred by the Agency and its counsel in connection with the attendant negotiations whether or not the transaction is carried to a successful conclusion.

The Applicant further understands and agrees with the Agency as follows:

- 1. Annual Sales Tax Filings.** In accordance with Section 858-b(2) of the New York General Municipal Law, the Applicant understands and agrees that, if the Project receives any sales tax exemptions as part of the Financial Assistance from the Agency, in accordance with Section 874(8) of the General Municipal Law, the Applicant agrees to file, or cause to be filed, with the New York State Department of Taxation and Finance, the annual form prescribed by the Department of Taxation and Finance, describing the value of all sales tax exemptions claimed by the Applicant and all consultants or subcontractors retained by the Applicant.
- 2. Annual Employment, Tax Exemption & Bond Status Reports.** The Applicant understands and agrees that, if the Project receives any Financial Assistance from the Agency, the Applicant agrees to file, or cause to be filed, with the Agency, on an annual basis, reports regarding the number of people employed at the project site as well as tax exemption benefits received with the action of the Agency. For Applicants not responding to the Agency's request for reports by the stated due date, a \$500 late fee will be charged to the Applicant for each 30-day period the report is late beyond the due date, up until the time the report is submitted. Failure to provide such reports as provided in the transaction documents will be an Event of Default under the Lease (or Leaseback) Agreement between the Agency and Applicant. In addition, a Notice of Failure to provide the Agency with an Annual Employment, Tax Exemption & Bond Status Report may be reported to Agency board members, said report being an agenda item subject to the Open Meetings Law.
- 3. Absence of Conflict of Interest.** The Applicant has consulted the Agency website of the list of the Agency members, officers and employees of the Agency. No member, officer, or employee of the Agency has an interest, whether direct or indirect, in any transaction contemplated by this Application, except as herein after described (if none, state "none").
- 4. Hold Harmless.** Applicant hereby releases the Agency and its members, officers, servants, agents and employees from, agrees that the Agency shall not be liable for and agrees to indemnify, defend and hold the Agency harmless from and against any and all liability arising from or expense incurred by (A) the Agency's examination and processing of, and action pursuant to or upon, the attached Application, regardless of whether or not the Application or the Project described therein or the tax exemptions and other assistance requested therein are favorably acted upon by the Agency, (B) the Agency's acquisition, construction and/or installation of the Project described therein and (C) any further action taken by the Agency with respect to the Project; including without limiting the generality of the foregoing, all causes of action and attorneys' fees and any other expenses incurred in defending any suits or actions which may arise as a result of any of the foregoing. If, for any reason, the Applicant fails to conclude or consummate necessary negotiations, or fails, within a reasonable or specified period of time, to take reasonable, proper or requested action, or withdraws, abandons, cancels or neglects the Application, or if the Agency or the Applicant are unable to reach final

agreement with respect to the Project, then, and in the event, upon presentation of an invoice itemizing the same, the Applicant shall pay to the Agency, its agents or assigns, all costs incurred by the Agency in the processing of the Application, including attorneys' fees, if any.

5. The Applicant acknowledges that the Agency has disclosed that the actions and activities of the Agency are subject to the Public Authorities Accountability Act signed into law January 13, 2006 as Chapter 766 of the 2005 Laws of the State of New York.
6. The Applicant acknowledges that the Agency is subject to New York State's Freedom of Information Law (FOIL). Applicant understands that all Project information and records related to this application are potentially subject to disclosure under FOIL subject to limited statutory exclusions.
7. The Applicant acknowledges that it has been provided with a copy of the Agency's recapture policy (the "Recapture Policy"). The Applicant covenants and agrees that it fully understands that the Recapture Policy is applicable to the Project that is the subject of this Application, and that the Agency will implement the Recapture Policy if and when it is so required to do so. The Applicant further covenants and agrees that its Project is potentially subject to termination of Agency financial assistance and/or recapture of Agency financial assistance so provided and/or previously granted.
8. The Applicant understands and agrees that the provisions of Section 862(1) of the New York General Municipal Law, as provided below, will not be violated if Financial Assistance is provided for the proposed Project:

§ 862. Restrictions on funds of the agency. (1) No funds of the agency shall be used in respect of any project if the completion thereof would result in the removal of an industrial or manufacturing plant of the project occupant from one area of the state to another area of the state or in the abandonment of one or more plants or facilities of the project occupant located within the state, provided, however, that neither restriction shall apply if the agency shall determine on the basis of the application before it that the project is reasonably necessary to discourage the project occupant from removing such other plant or facility to a location outside the state or is reasonably necessary to preserve the competitive position of the project occupant in its respective industry.
9. The Applicant confirms and acknowledges that the owner, occupant, or operator receiving Financial Assistance for the proposed Project is in substantial compliance with applicable local, state and federal tax, worker protection and environmental laws, rules and regulations.
10. The Applicant confirms and acknowledges that the submission of any knowingly false or knowingly misleading information may lead to the immediate termination of any Financial Assistance and the reimbursement of an amount equal to all or part of any tax exemption claimed by reason of the Agency's involvement the Project.
11. The Applicant confirms and hereby acknowledges that as of the date of this Application, the Applicant is in substantial compliance with all provisions of Article 18-A of the New York General Municipal Law, including, but not limited to, the provision of Section 859-a and Section 862(1) of the New York General Municipal Law.
12. The Applicant and the individual executing this Application on behalf of the Applicant acknowledge that the Agency will rely on the representations made herein when acting on this Application and hereby represent that the statements made herein do not contain any untrue statement of a material



fact and do not omit to state a material fact necessary to make the statements contained herein not misleading.

STATE OF NEW YORK )  
COUNTY OF ONEIDA ) ss.:

David Quirello, being first duly sworn, deposes and says:

1. That I am the CFO (Corporate Office) of Central Ulica Building, LLC/CNY Cardiology, PC (Applicant) and that I am duly authorized on behalf of the Applicant to bind the Applicant.
2. That I have read the attached Application, I know the contents thereof, and that to the best of my knowledge and belief, this Application and the contents of this Application are true, accurate and complete.

*David Quirello*

(Signature of Officer)

Subscribed and affirmed to me under penalties of perjury  
this \_\_\_ day of \_\_\_\_\_, 20 .

\_\_\_\_\_  
(Notary Public)

If the application has been completed by or in part by other than the person signing this application for the applicant please indicate who and in what capacity:

By: \_\_\_\_\_

Name: Bruce Smith

Title: Esquire

Date: 11/1/2021

**Please submit the signed and notarized completed application along with payment of a non-refundable \$500 Application Fee and a \$1,000 Commitment Fee (will be applied to final closing costs) to the Oneida County Industrial Development Agency, 584 Phoenix Drive, Rome NY 13441-1405, within 14 days prior to the OCIDA Board of Directors meeting at which you want the Application to be included on the Agenda.** Wire transfer and ACH payments are acceptable but all related fees incurred by the Agency are payable by the Applicant. It is advised that an electronic version of the application accompany the original application via hard copy or e-mail. An electronic version of the application must accompany the original application via physical media or e-mail.

Anthony J. Pirante Jr.  
County Executive

Shawna M. Papale Executive  
Director/Secretary

Jennifer Waters  
Assistant Secretary

ONEIDA COUNTY INDUSTRIAL  
DEVELOPMENT AGENCY

**OCIDA**



584 Phoenix Road, New York 13441-4105  
Ph: (315) 338-0193, Fax: (315) 338-5694  
info@nverge.org www.oneidacountyida.org

David B. Grow  
Chair

L. Michael Fitzgerald  
Vice-Chair

Mary Faith Messenger  
Treasurer

Ferris Betrus  
Kirk Hinman

Eugene Quadraro  
Steven Zoghy

## MEMORANDUM TO COMPANIES SALE-LEASEBACK TRANSACTIONS

1. When a Company decides that a sale-leaseback transaction may suit its particular needs, the first order of business is for the Company to complete an Application for Financial Assistance, together with an Environmental Impact Questionnaire, Cost/Benefit Analysis and Statement of the Project Applicant (referred to collectively as the "Application"). The Application is submitted to Agency Counsel for a formal decision as to whether or not the project qualifies as a "project," as defined by law.
2. No action can be taken until the Application is completed and submitted to the Agency and approved by Agency Counsel.
3. Upon completion of the Application and approval by Agency Counsel, the Agency will meet for the purpose of adopting an Inducement Resolution and reviewing the Environmental Impact Questionnaire, Cost/Benefit Analysis and Statement of the Project Applicant. At this time a Resolution may be adopted by the Agency concerning the environmental impact. **Please note that the Agency is subject to the Open Meetings Law, and all meetings will be open to the public, including news media.**
4. The Company is expected and encouraged to have its own counsel. The Company is also required to reimburse the Agency for all legal expenses incurred in furtherance of a proposed transaction, whether or not that transaction is completed. This includes all fees and disbursements of Agency Counsel.
5. The Company will be asked to sign an Inducement Agreement, which sets forth the terms of the proposed transaction and the obligations of the parties in furtherance of the same. The Company will also be asked to provide Agency Counsel with certain

information concerning the formation of the corporation or partnership, a survey of the property, title insurance, insurance certificates, etc. before the transaction can close. All matters in connection with the transfer of the real estate will be handled primarily by Company Counsel with the assistance of Agency Counsel.

6. A Public Hearing may be required in accordance with the New York State General Municipal Law, after which the Oneida County Executive must approve or disapprove the issue. Notice of the Public Hearing must be published at least thirty (30) days prior to the Hearing in the newspaper where the project is located. The highest elected official of each affected taxing jurisdiction must also receive thirty day written notice of the Hearing.

No financial benefits may be granted by the Agency to the Company until after the Public Hearing if required.

7. Agency Counsel has certain requirements as to those documents which must be included in the transaction and the content thereof, including but not limited to requiring environmental impact surveys, environmental indemnifications and general indemnifications.
8. The fee schedule is attached, covering the Agency fee, the Agency's work with respect to the project and the work of Agency Counsel.

The estimated fees for Agency Counsel may vary depending on the nature of the project. The initial fee quote assumes that the transaction closes within ninety (90) days from the date of the inducement, that there will be no unusual questions of law or prolonged negotiations regarding the documents, and that the involvement or assistance from other agencies will not require substantial modifications to the typical structure and documentation of similar transactions. The fee quote also assumes that Agency Counsel will not be called upon to coordinate with any lender, as the Agency is not issuing bonds. The fee quote assumes that closing will take place by mail and will not necessitate attending meetings with the Company or any lender.

9. Once the terms and conditions of the transaction are fairly well established, Agency Counsel prepares preliminary drafts of the financing documents and distributes them to all parties for review and comment. Comments accepted by all counsel will result in redrafting of documents. The parties establish a mutually agreeable closing date, and final documents for execution are prepared.

10. The Agency then conducts a meeting whereby it adopts an Authorizing Resolution, under which the Agency approves of the form of the documents and authorizes the Chairman to execute the same.
11. The closing takes place.
12. Some of the benefits available to a company under a sale-leaseback transaction are as follows:
  - ⇒ Exemption from New York State mortgage recording tax
  - ⇒ Exemption from New York State sales tax for materials used in construction
  - ⇒ Real property tax abatement on the value added to the project (for more information, please see the Uniform Tax Exemption Policy enclosed herewith)

c:\1997\ncld\z\hrmemo3.doc\lar\_pe

**MEMORANDUM TO APPLICANTS FINANCING AN IDA PROJECT  
THROUGH A COMMERCIAL LENDER**

We have found it helpful to outline at the onset of a transaction the basic structure of financing when an industrial development agency ("IDA") has a fee or leasehold interest in a property and is party to a mortgage or other financing instrument. **Please give a copy of this memorandum to your lender as early in the financing process as possible.**

An IDA is party to a financing instrument purely as a conduit for financial assistance (in the case of granting exemptions from mortgage recording tax) and to grant its interest in the facility to the lender. To preserve the passive nature of its role, the IDA cannot assume any obligations or make any representations that a traditional Borrower would make to a lender. It has been our experience that the easiest way to accomplish this is to define the Borrower as the "Borrower," define the IDA as the "Agency," and only include the Agency in the granting clause and with respect to the assignment of rents, inasmuch as those are the only reasons that the Agency is party to this document.

Furthermore, because PILOT Payments are contractual obligations and are not given the same high priority as tax payments, we crafted some language that will restore the taxing jurisdictions to the same position they would have been but not for the IDA involvement in the project. While it is not disputed that is an equitable arrangement, certain lenders have expressed concern that, because the requirement to pay PILOT Payments is contained in a private contract, there is no prescribed process to avoid significant delinquencies as there is under a tax foreclosure. It has been our experience the easiest way to accomplish this is for a lender to escrow PILOT Payments so it has the assurance that payments are made in a timely manner. If a lender does not wish to escrow PILOT Payments, an alternative is for the IDA to record a PILOT Mortgage that would be given first priority over the lender's mortgage, similar to the priority taxes have.

Below are certain provisions we require be incorporated into each financing document to which the IDA is a party (please modify capitalized terms accordingly):

**1. AGENCY PROVISIONS.**

a. Agency makes no covenants other than to mortgage all of its interest in the Premises excepting its Unassigned Rights (as said term is defined in the Leaseback Agreement).

b. **NO RECOURSE AGAINST AGENCY:** Lender agrees that Lender will not look to the Agency or any principal, member, director, officer or employee of the Agency with respect to the Indebtedness or any covenant, stipulation, promise, agreement or obligation contained in this Mortgage. In enforcing its rights and remedies under this Mortgage, Lender will look solely to the Premises for the payment of the Indebtedness and for the performance of the provisions hereof. Lender will not seek a deficiency or other money judgment against the Agency or any principal, member, director, officer or employee of the Agency and will not institute any separate action against the Agency by reason of any default which may occur in the performance of any of the terms and conditions of any documents evidencing the Indebtedness.

c. **HOLD HARMLESS:** Borrower and Lender agree that the Agency, its directors, members, officers, agents (except the Borrower) and employees shall not be liable for and Borrower agrees to defend, indemnify, release and hold the Agency, its directors, members, officers, agents (except the Borrower) and employees harmless from and against any and all (i) liability for loss or damage to Property or injury to or death of any and all Persons that may be occasioned by, directly or indirectly, any

cause whatsoever pertaining to the Facility or arising by reason of or in connection with the occupation or the use thereof or the presence of any Person or Property on, in or about the Facility or the Land or (ii) liability arising from or expense incurred by the Agency's financing, acquiring, constructing, renovating, equipping, owning and leasing of the Facility, including without limiting the generality of the foregoing, all claims arising from the breach by the Borrower of any of their respective covenants contained herein and all causes of action and attorneys' fees and any other expenses incurred in defending any claims, suits or actions which may arise as a result of any of the foregoing, provided that any such losses, damages, liabilities or expenses of the Agency are not incurred or do not result from the gross negligence or intentional or willful wrongdoing of the Agency, or any of its directors, members, agents (except the Borrower) or employees. The foregoing indemnities shall apply notwithstanding the fault or negligence in part of the Agency or any of its members, directors, officers, agents or employees and irrespective of the breach of a statutory obligation or the application of any rule of comparative or apportioned liability.

d. **SPECIAL OBLIGATION.** The obligations of the Agency under the Mortgage and Financing Documents constitute a special obligation of the Agency, and all charges payable pursuant to or expenses or liabilities incurred thereunder shall be payable solely out of the revenues and other moneys of the Agency derived and to be derived from the leasing of the Facility, any sale or other disposition of the Equipment and as otherwise provided in the Authorizing Resolution, the Leaseback Agreement and the PILOT Agreement. Neither the members, officers, agents (except the Borrower) or employees of the Agency, nor any person executing the Mortgage and Financing Documents on behalf of the Agency, shall be liable personally or be subject to any personal liability or accountability by reason of the leasing, construction, renovation, equipping or operation of the Facility. The obligations of the Agency under the Financing Documents are not and shall not be an obligation of the State or any municipality of the State and neither the State nor any such municipality (including, without limitation, the County of Oneida), shall be liable thereon.

c. **SUBORDINATION TO PILOT AGREEMENT:** This Mortgage shall be subject and subordinate to any PILOT Agreement between the Borrower and the Agency with respect to the payments in lieu of taxes assessed or imposed upon the Premises, and by accepting this Mortgage, Lender acknowledges and agrees that such PILOT payments shall have the same force, priority and effect as a real property tax lien under New York State law against the Premises.

If a lender chooses to escrow PILOT Payments, we will incorporate the following provisions into the Leaseback (or Lease) Agreement:

Section 9.13 Subordination to Mortgage. This Leaseback Agreement and the rights of the Company and the Agency hereunder (other than with respect to the Unassigned Rights) are subject and subordinate to the Lien of the Mortgage, and all extensions, renewals or amendments thereof. The subordination of this Leaseback Agreement to the Mortgage shall be automatic, without execution of any further subordination agreement by the Company or the Agency. Nonetheless, if the Bank requires a further written subordination agreement, the Company and the Agency hereby agree to execute, acknowledge and deliver the same.

Section 9.14 Rights of Bank.

(a) Bank is hereby given the right by the Agency, in addition to any other rights herein granted, without any requirement to obtain the Agency's consent, to mortgage the mortgagors' respective interests in the Facility and, in the case of the Company, to assign and grant a security interest in the Company's rights under the Company Documents as collateral security for its obligations to the Bank, upon the condition that all rights acquired by Bank shall be subject to all rights and interests of the

Agency herein and in the other Company Documents, none of which covenants, conditions or restrictions is or shall be waived by the Agency by reason of this right to mortgage or grant a security interest in the Facility and the Company Documents, including Unassigned Rights.

(b) There shall be no renewal, cancellation, surrender, acceptance of surrender, material amendment or material modification of this Leaseback Agreement or any other Company Document by joint action of the Agency and the Company alone, without, in each case, the prior consent in writing of Bank, nor shall any merger result from the acquisition by, or devolution upon, any one entity of any fee and/or leasehold estates or other lesser estates in the Facility. Failure of the Bank to consent to a modification of this Leaseback Agreement by the Agency shall constitute an Event of Default.

(c) If the Agency serves a notice of default upon the Company, it shall also serve a copy of such notice upon Bank at the address set forth in Section 9.1.

(d) In the event of any default by the Company under this Leaseback Agreement or any other Company Document, the Bank shall have fifteen (15) days for a monetary default and thirty (30) days in the case of any other default, after notice to the Company and the Bank of such default to cure or to cause to be cured the default complained of and the Agency shall accept such performance by or at the instigation of Bank as if same had been done by the Company. The Agency in its sole discretion will determine whether such action by the Bank amounts to a cure.

(e) Except where Bank or its designee or nominee has succeeded to the interest of the Company in the Facility, no liability for any payments to be made pursuant to this Agreement or the performance of any of the Company's covenants and agreements under this Agreement shall attach to or be imposed upon the Bank, and if the Bank or its nominee or designee succeeds to the interest of the Company in the Project, all of the obligations and liabilities of the Bank or its nominee or designee shall be limited to such entity's interest in the Facility and shall cease and terminate upon assignment of this Leaseback Agreement by the Bank; provided however, that the Bank or its nominee or designee shall pay all delinquent PILOT Payments, if any, prior to said assignment.

(g) Notwithstanding any provision of this Leaseback Agreement or any other Company Document to the contrary, foreclosure of a mortgage or any sale of the Company's interest in this Leaseback Agreement and/or the Facility in connection with a foreclosure, whether by judicial proceedings, or any conveyance of the Company's interest in this Agreement and/or the Facility to Bank by virtue of or in lieu of foreclosure or other appropriate proceedings, or any conveyance of the Company's interest in this Leaseback Agreement and/or the Facility by Bank shall not require the consent or approval of the Agency and failure to obtain the Agency's consent shall not be a default or Event of Default hereunder.

**Oneida County Industrial Development Agency Recapture Policy  
(Effective April 25, 2017)**

**DEFINITIONS:**

"Company"	is the entity that applied for and received a benefit from the Agency.
"Agency"	is the Oneida County Industrial Development Agency.
"AER"	is the Company's annual report of employment required to be provided to the Agency.
"Employment Obligation Term"	shall mean the period during which the Company is receiving a benefit in the form of lower payment in lieu of taxes than their real estate taxes would be.
"Employment Obligation"	shall mean the number of FTEs employed by the Company in Oneida County and selected by the Agency as the Company's obligation.
"FTE"	shall mean a full time employee that has a minimum of thirty-five (35) scheduled hours per week, or any combination of two or more part-time employees that work a minimum of fifteen (15) scheduled hours per week, when combined together, constitute the equivalent of a minimum of thirty-five (35) scheduled hours per week, and whose workplace location is the project facility. For this purpose an employee shall include a leased employee regularly retained by the Company.
"Benefit"	shall mean the amount the Company saved by making payments in lieu of real property taxes in a particular year. For example, if a Company's PILOT payment is equal to 75% of normal real property taxes, then the Company's Benefit for that year would be an amount equal to 25% of normal real property taxes.
"Per Employee Amount"	shall mean an amount equal to the Benefit for the year after the year of the Shortfall divided by the "Employment Obligation".
"Shortfall"	shall mean the difference between the Employment Obligation and the actual number of FTEs per the AER for the applicable year.
"Major Shortfall"	shall mean having FTEs that are less than 50% of the Employment Obligation.
"Minimum Standard"	shall mean a Company whose AER shows that they are short of meeting its Employment Obligation by 20%.
"Initial Benefit"	shall be the amount of savings the Company received through the Agency, in the form of Mortgage Recording Tax and New York State Sales Tax.
"Cure Period"	shall mean the period ending June 30 <sup>th</sup> of the year following the Major Shortfall.



1. **Job Creation and Retention Obligations.**

After the expiration of the Employment Obligation Term, the Company shall have no further obligation with respect to the Employment Obligation and shall not be liable for any of the payments described below.

The failure of the Company to satisfy the Employment Obligation can subject the Company to payments to the Agency. The Company shall be required to make payments if it fails to attain the Minimum Standard.

If the Company falls below the Minimum Standard, the Agency will notify the Company in writing of the Agency's intention to recapture Financial Assistance. The Company will have thirty (30) days to respond to the letter and may include a request to appear before the Agency. The Agency will determine, in its sole discretion, if a valid exemption exists and potentially reduce the remedies described below.

2. **Projects with less than Ten Years Employment Obligation Term.**

(a) **Shortfall Payments.**

- (1) If, during the first three (3) years of the Employment Obligation Term a Company fails to achieve the Minimum Standard, then the Company shall pay to the Agency an amount equal to (a) the Per Employee Amount multiplied by (b) the Shortfall and then multiplied by (c) 1.5.
- (2) If, after the first (3) years, of the Employment Obligation Term a Company fails to achieve the Minimum Standard, then the Company shall pay to the Agency an amount equal to (a) the Per Employee Amount multiplied by (b) the Shortfall.

(b) **Major Shortfall Payment.**

- (1) If a Company shall incur a Major Shortfall; then, the Company shall pay to the Agency as an additional one-time payment an amount as set forth in the schedule below (such payment shall be referred to as the "Major Shortfall Payment").

<b><u>Major Shortfall Occurs:</u></b>	<b><u>Percentage of Initial Benefit</u></b>
Year 1	100%
Year 2	80%
Year 3	60%
Year 4	40%
Any Subsequent Year	20%

- (2) Notwithstanding any of the foregoing, the Company shall not be liable for a Major Shortfall Payment unless the number of FTEs remains at less than 65% of the Employment Obligation at the expiration of a Cure Period. The Company shall have the opportunity at any time before the expiration of a Cure Period to provide additional information to the Agency regarding the Major Shortfall, and to request a waiver or amendment of this provision.

- (3) Notwithstanding any of the foregoing, a Major Shortfall shall not apply where the Shortfall is a result of a major casualty to or condemnation of the facility. In the event of such major casualty or condemnation, the Company shall have no obligation to pay the Major Shortfall Payment.
- (4) Qualification for a waiver of either (2) or (3) above shall be at the sole discretion of the Agency.

3. **Projects with Ten Years or Longer Employment Obligation Term.**

(a) **Shortfall Payments.**

- (1) If, during the first five (5) years of the Employment Obligation Term a Company fails to achieve the Minimum Standard, then the Company shall pay to the Agency an amount equal to (a) the Per Employee Amount multiplied by (b) the Shortfall and then multiplied by (c) 1.5.
- (2) If, after the first five (5) years of the Employment Obligation Term a Company fails to achieve the Minimum Standard, then the Company shall pay to the Agency an amount equal to (a) the Per Employee Amount multiplied by (b) the Shortfall.

(b) **Major Shortfall Payment.**

- (1) If a Company shall incur a Major Shortfall, then the Company shall pay to the Agency as an additional one-time payment an amount as set forth in the schedule below.

<b><u>Major Shortfall Occurs:</u></b>	<b><u>Percentage of Initial Benefit</u></b>
Year 1	100%
Year 2	90%
Year 3	80%
Year 4	70%
Year 5	60%
Year 6	50%
Year 7	45%
Year 8	40%
Year 9	35%
Year 10	30%

- (2) Notwithstanding any of the foregoing, the Company shall not be liable for a Major Shortfall Payment unless the number of FTEs remains at less than 65% of the Employment Obligation at the expiration of a Cure Period. The Company shall have the opportunity at any time before the expiration of a Cure Period to provide additional information to the Agency regarding the Major Shortfall, and to request a waiver or amendment of this provision.
- (3) Notwithstanding any of the foregoing, a Major Shortfall shall not apply where the Shortfall is as a result of a major casualty to or condemnation of the facility. In the event of such major casualty or condemnation, the Company shall have no obligation to pay the Major Shortfall Payment.

(4) Qualification for a waiver of either (2) or (3) above shall be at the sole discretion of the Agency.

4. **Shift of Employment.** If the Shortfall or Major Shortfall is as a result of the Company shifting employment away from Oneida County, then the Agency will require the value of the Benefit and the Initial Benefit utilized to date to be repaid, with interest (determined as the New York State legal interest rate).

5. **Mandatory Recapture.** The Agency is mandated to recapture New York State sales tax benefits where:

- a. The Project is not entitled to receive those benefits.
- b. The exemptions exceed the amount authorized, or are claimed for unauthorized property or services.
- c. The Company fails to use property or services in the manner required by the Leaseback Agreement.

6. **Return of Recaptured Funds.** If the Agency recaptures Initial Benefits or Benefits from a Company, the Agency shall return the recaptured funds promptly to the affected taxing jurisdiction, unless otherwise agreed to by the taxing jurisdiction, in accordance with the General Municipal Law.

**The Agency shall have the right to reduce any payment required under this Policy, in extraordinary circumstances, in its sole discretion.**

## Oneida County Industrial Development Agency

### Insurance Requirements Under Leaseback Agreement

#### Section 3.4 Insurance Required.

At all times throughout the Lease Term, including, when indicated herein, during the Construction Period, the Company shall, at its sole cost and expense, maintain or cause to be maintained (and cause the Sublessees to maintain, where appropriate) insurance of the following types of coverage and limits of liability with an insurance carrier qualified and admitted to do business in New York State. The Insurance carrier must have at least an A- (excellent) rating by A. M. Best. Company shall pay, as the same become due and payable, all premiums with respect thereto, including, but not necessarily limited to:

(a) **Property Insurance:** Insurance against loss or damage by fire, lightning and other casualties customarily insured against in an all risk policy with special form perils, such insurance to be in an amount not less than the full replacement value of the completed Improvements, exclusive of footings and foundations, as determined by a recognized appraiser or insurer selected by the Company. During the Construction Period, such policy shall be written in the so-called "Builder's Risk Completed Value Non-Reporting Form" and shall contain a provision granting the insured permission to complete and/or occupy.

(b) **Workers' Compensation & Employers Liability Insurance and Disability Benefits Insurance** and each other form of insurance that the Company or any permitted sublessee is required by law to provide, covering loss resulting from injury, sickness, disability or death of employees of the Company or any permitted sublessee who are located at or assigned to the Facility. Statutory New York limits shall apply to these policies. This coverage shall be in effect from and after the Completion Date or on such earlier date as any employees of the Company, any permitted sublessee, any contractor or subcontractor first occupy the Facility.

(c) **General Liability Insurance** protecting the Agency and the Company against loss or losses from liability imposed by law or assumed in any written contract (including the contractual liability assumed by the Company under Section 5.2 hereof) and arising from personal injury, including bodily injury or death, or damage to the property of others, caused by an accident or occurrence with a limit of liability of not less than \$1,000,000 per occurrence and \$2,000,000 annual aggregate. **Comprehensive Automobile Liability Insurance** including all owned, non-owned and hired autos with a limit of liability of not less than \$1,000,000 (combined single limit or equivalent for personal injury, including bodily injury or death, and property damage) protecting the Agency and the Company against any loss or liability or damage for personal injury, including bodily injury or death, or property damage, and **Umbrella Liability Insurance** of not less than \$5,000,000 per occurrence. This coverage shall also be in effect during the Construction Period.

(d) During the Construction Period (and for at least two years thereafter in the case of Products and Completed Operations as set forth below), the Company shall cause the general contractor to carry liability insurance of the type and providing the minimum limits set forth below:

(i) Workers' compensation & employer's liability and disability benefits insurance both with statutory limits in accordance with applicable law.

(ii) Comprehensive general liability providing coverage for:  
Premises and Operations  
Products and Completed Operations  
Contractual Liability  
Personal Injury Liability  
Broad Form Property Damage  
(including completed operations)  
Explosion Hazard  
Collapse Hazard  
Underground Property Damage Hazard

Such insurance shall have a limit of liability of not less than \$1,000,000 per occurrence and \$2,000,000 annual aggregate. The annual aggregate shall apply per project. The contractor's general liability policy shall include coverage for the contractor and any of the additional insureds for any operations performed on residential projects including single or multi-family housing, residential condominiums, residential apartments and assisted living facilities.

(iii) Comprehensive auto liability, including all owned, non-owned and hired autos, with a limit of liability of not less than \$1,000,000 (combined single limit for personal injury, including bodily injury or death, and property damage).

(iv) Umbrella Liability with limits of \$5,000,000 per occurrence and \$5,000,000 annual aggregate.

(e) A policy or policies of flood insurance in the maximum amount of flood insurance available with respect to the Facility under the Flood Disaster Protection Act of 1973, as amended, whichever is less. This requirement will be waived upon presentation of evidence satisfactory to the Agency that no portion of the Land is located within an area identified by the U.S. Department of Housing and Urban Development as having special flood hazards.

### Section 3.5 Additional Provisions Respecting Insurance.

(a) All insurance required by Section 3.4 hereof shall be procured and maintained in financially sound and generally recognized responsible insurance companies selected by the entity required to procure the same and authorized to write such insurance in the State. Such insurance may be written with deductible amounts comparable to those on similar policies carried by other companies engaged in businesses similar in size, character and other respects to those in which the procuring entity is engaged. All policies evidencing the insurance required by Section 3.4 hereof shall provide for at least thirty (30) day's prior written notice of the restriction, cancellation or modification thereof to the Agency. The policies evidencing the insurance required by Section 3.4(c) hereof shall name the Agency as additional insured on a primary & non-contributory basis. All policies evidencing the insurance required by Sections 3.4(d)(ii) (iii) and (iv) shall name the Agency and Company as additional Insured on a primary and non-contributory basis for the ongoing construction phase and for two years following completion during the completed operations phase. The policies under Section 3.4 (a) shall contain appropriate waivers of subrogation. The policies under Section 3.4 (b),(c),(d) shall contain waivers of subrogation in favor of the Agency and Company.

(b) All policies or certificates (or binders) of insurance required by Sections 3.4 hereof shall be submitted to the Agency on or before the Closing Date. Attached to the certificate of insurance shall be a copy of the additional insured endorsement from the Company's General Liability policy. The Company shall deliver to the Agency before the renewal date of each policy a certificate dated not earlier than the immediately preceding month reciting that there is in full force and effect, with a term covering at least the next succeeding calendar year, insurance of the types and in the amounts required by Section 3.4 hereof and complying with the additional requirements of Section 3.5(a) hereof. Prior to the expiration of each such policy, the Company shall furnish the Agency with evidence that such policy has been renewed or replaced or is no longer required by this Leaseback Agreement. The Company shall provide such further information with respect to the insurance coverage required by this Leaseback Agreement as the Agency may from time to time reasonably require.

Agency shall be named as additional insured as follows:

Oneida County Industrial Development Agency, ISAOA  
584 Phoenix Drive  
Rome, New York 13441

Anthony J. Picante Jr.  
County Executive

Shawna M. Papale  
Secretary/  
Executive Director

Jennifer Waters  
Assistant Secretary

ONEIDA COUNTY INDUSTRIAL  
DEVELOPMENT AGENCY

**OCIDA**



584 Phoenix Drive, Rome, New York 13441-4105  
(315) 338-0393, fax (315) 338-5694  
info@mvedge.org www.oneidacountylda.org

David C. Grow  
Chairman

L. Michael Fitzgerald  
Vice Chair

Mary Faith Messenger  
Treasurer

Ferris Betrus Jr.  
Kirk Hinman  
Eugene Quadraro  
Stephen Zogby

---

## ONEIDA COUNTY INDUSTRIAL DEVELOPMENT AGENCY UNIFORM TAX EXEMPTION POLICY

---

Adopted by the Oneida County Industrial Development Agency on  
January 28, 1994, amended on December 21, 1998 and April 30, 2009

The Oneida County Industrial Development Agency (the "Agency") has adopted the following uniform tax exemption policies. These policies will be used for all projects for which the Agency may provide financial assistance, including bond (taxable and/or tax exempt) issuances and straight lease transactions. Final determinations regarding the extent to which financial assistance, if any, will be granted are solely within the discretion of the Agency.

### I. **Project Eligibility Criteria**

#### (a) **General Requirements**

The Agency considers the following general factors in determining whether a project is eligible for financial assistance:

- The nature of the proposed project (e.g., manufacturing, commercial, civic).
- The nature of the property before the project begins (e.g., vacant land, vacant buildings).
- The economic condition of the area at the time of the application.
- The extent to which a project will create or retain permanent, private sector jobs.
- The estimated value of tax exemptions to be provided.
- The impact of the project and the proposed tax exemptions on affected tax jurisdictions.
- The impact of the proposed project on existing and proposed businesses and economic development projects in the County.
- The amount of private sector investment generated or likely to be generated by the proposed project.
- The likelihood of accomplishing the proposed project in a timely fashion.
- The effect of the proposed project upon the environment.

- 
- The extent to which the proposed project will provide additional sources of revenue for municipalities and school districts in which the project is located.
  - The extent to which the proposed project will provide a benefit (economic or otherwise) not otherwise available within the County of Oneida.

**(b) Industrial and Manufacturing Projects**

(1) Industrial and manufacturing projects generally qualify for financial assistance, subject to the eligibility criteria set forth in Part I (a) of this Policy.

(2) Due to the nature of the work, companies performing back-office operations that are regional or national in nature and a majority of which operations support activities outside of Oneida County will qualify as industrial and manufacturing. Research and development facilities and distribution centers that locate in Oneida County may also qualify as industrial and manufacturing.

**(c) Retail Projects**

The Agency will provide financial assistance to retail facilities only in accordance with the restrictions contained in New York State General Municipal Law Section 862(2), and subject to the eligibility criteria set forth in Part I (a) of this Policy. The Agency will also consider the competitive impact of the project.

Retail projects are generally not eligible for Agency assistance, with the following exceptions:

(i) Retail businesses that primarily serve customers located in Oneida County are generally not eligible for financial assistance unless located in a "highly distressed area" as defined in General Municipal Law §854(18), which includes projects located in an economic development zone or Empire Zone (as defined in New York State statute or regulation), or the project meets one of the other requirements of this paragraph (c);

(ii) Retail projects operated by not-for-profit corporations may be eligible for financial assistance;

(iii) Retail projects may be eligible for financial assistance provided an appropriate market analysis demonstrates that a majority of the project's customers are expected to come from outside of Oneida County and the project will not directly compete with existing businesses located in Oneida County; and

(iv) Retail businesses that primarily provide a product or a service that is otherwise not reasonably available in Oneida County may be eligible for financial assistance.

**(d) Other Non-Industrial/Commercial Projects**

Non-industrial/commercial projects may qualify for financial assistance at the discretion of the Agency, based upon its evaluation of the eligibility requirements set forth in Part I (a) of this Policy. The Agency confirms the following specific policies:



(i) Mixed or Multiple-Use Projects qualify for financial assistance, only with respect to that portion of the project that is used for purposes that qualify for financial assistance under this Policy.

(ii) Housing projects are generally not eligible for benefits, unless they

(a) service the elderly, low-income, assisted living or other groups with special needs; or

(b) promote employment opportunities and prevent economic deterioration, as confirmed by an appropriate market analysis, and such a determination is made by the Agency based upon all of the relevant facts.

## II. Real Property Tax Abatements

If the Agency determines that a project will receive real property tax abatements, a Payment-In-Lieu-Of-Tax Agreement (the "PILOT") will be negotiated with each project owner (the "Company") and will substantially follow the following guidelines with final determinations to be made by the Agency.

(i) Real Property Acquired by Company as part of Project. If the Company is acquiring real property as part of the Agency project, then the Agency's real property tax exemption will be available with respect to all real property acquired by the Company as part of the project and improvements thereto.

(ii) Substantial Improvements to Existing Real Property Owned by Company. If the Company is making "Substantial Improvements" (as defined below) to existing real property owned by the Company, then the Agency's real property tax exemption will apply to both the existing real property and the improvements.

(iii) Non-Substantial Improvements to Existing Real Property. If the improvements to existing real property owned by the Company are not Substantial Improvements, then the Agency's tax exemption shall apply only to the increase in assessment resulting from improvements constructed or installed as part of the project and the Company shall pay PILOT payments equal to the full amount of taxes on the existing real property.

The term "Substantial Improvements" means the value of the improvements constructed or installed as part of the project equals at least 50% of the value of the real property prior to construction or installation of the improvements, as determined by an independent valuation acceptable to the Agency.

### (a) Industrial and Manufacturing Projects

The Company shall pay a percentage of the taxes that would otherwise be payable if the project was not tax exempt, to each taxing jurisdiction in which the project is located, as follows:

1. 33 1/3% of such taxes through the fifth (5th) year of the exemption;

- 
2. 66 2/3% of such taxes from the sixth (6th) through tenth (10th) year of the exemption;
  3. 100% of such taxes after the tenth (10th) year of the exemption.

**(b) Retail Projects**

The Company shall pay a percentage of the taxes that would otherwise be payable if the project was not tax exempt, to each taxing jurisdiction in which the project is located, as follows:

1. 50% of such taxes through the second (2nd) year of the exemption;
2. 75% of such taxes from the third (3rd) through the fifth (5th) year of the exemption;
3. 100% of such taxes after the fifth (5th) year of the exemption.

**(c) Other Non-Industrial/Commercial Projects**

The Company shall pay a percentage of the taxes that would otherwise be payable if the project was not tax exempt, to each taxing jurisdiction in which the project is located, as follows:

1. 50% of such taxes through the second (2nd) year of the exemption.
2. 75% of such taxes from the third (3rd) through fifth (5th) year of the exemption.
3. 100% of such taxes after the fifth (5th) year of the exemption.

The Agency reserves the right to deviate from the real property tax abatement policy on a case by case basis at its sole discretion.

**III. Sales Tax Exemptions**

If, based on the eligibility criteria described in Part I of this Policy, the Agency determines a project is eligible for financial assistance, the Agency's financial assistance will include exemption from sales and use tax for costs of constructing, renovating and equipping the project.

Sales and use tax exemption, when available, will be authorized for the duration of the acquisition, construction and equipping of the project as described in the application for financial assistance. The Agency shall deliver a sales tax exemption letter which will expire one (1) year from the date of the project inducement. If construction, renovation or equipping is not complete at the expiration of the original sales tax exemption letter, upon request by the Company, the sales tax exemption letter may be extended at the discretion of the Agency.

All Companies receiving sales and use tax exemption benefits will be required to supply the Agency with a list of all contractors and sub-contractors that have been authorized to use the sales tax exemption letter. This list will be appended to the sales tax exemption letter by the Agency.

---

The Company must keep a record of the usage of the sales tax exemption letter, and must supply the Agency with the total amount of sales and use tax exemptions claimed by the project for each calendar year. The Company must submit this report to the Agency by February 1st of each year, until the exempt period comes to a conclusion. The company shall also file all reports as may be required by applicable law, including Form ST-340 which shall be filed with the New York State Department of Taxation and Finance.

The Agency reserves the right to deviate from the sales tax exemption policy on a case by case basis at its sole discretion.

#### **IV. Mortgage Recording Tax Exemption**

If, based on the project eligibility criteria described in Part I of this Policy, the Agency determines a project is eligible for financial assistance, the Agency will provide an exemption from New York State mortgage recording tax for the financing of project costs.

The Agency reserves the right to deviate from the mortgage recording tax exemption policy on a case by case basis at its sole discretion.

#### **V. Recapture**

Agency financial assistance is granted based upon the Company's representation that the project will create and/or maintain the employment levels described in its application for financial assistance (the "Employment Obligation"). If a Company fails to achieve and/or maintain its Employment Obligation, it could result in recapture of all or a portion of tax benefits granted by the Agency.

#### **VI. Deviations**

Deviations from this Policy shall be infrequent. The Agency reserves the right, at its sole discretion, to deviate from this Policy on a case by case basis. The Agency will provide written notice to the chief executive officer of each affected tax jurisdiction of any deviation from this Policy and will comply with the deviation requirements of the General Municipal Law.

April 2, 2018

Oneida County Industrial Development Agency (OCIDA)  
Uniform Tax Exemption Policy  
Business Relocation Assistance  
(Mohawk Valley Health Systems Project)

Purpose:

- The preference for all businesses displaced by the Mohawk Valley Health System ("MVHS") Project is to have them remain inside the City of Utica. The OCIDA recognizes that this may not be possible for all those business and this policy is to provide financial assistance to help mitigate costs of relocation for "Eligible Businesses" that will be impacted by the MVHS project.
- In keeping with the broader purpose of OCIDA to promote, develop, encourage or assist in the acquiring, constructing, reconstructing, improving, maintaining, equipping and furnishing of facilities in Oneida County and thereby advance the job opportunities, health, general prosperity and economic welfare of the people of Oneida County, if an Eligible Business commits to invest in a Replacement Property (above relocation costs) and/or create additional jobs, OCIDA may be able to offer additional financial assistance to an Eligible Business under its Uniform Tax Exemption Policy.

Eligible Businesses:

- Must have operated a business in the "Project Zone" and had employees whose place of employment was in the Project Zone during each month of 2017. "Project Zone" refers to any real estate located within the perimeter shown on the attached map that the Eligible Business owned or leased (under a written lease agreement) for all of 2017.
- To be eligible for financial assistance, an Applicant must have received an offer letter from MVHS and entered into an agreement with MVHS for the sale of its property in furtherance of the MVHS project.
- Industrial, commercial, back-office businesses and certain qualifying retail businesses (retail businesses that are relocating to a "highly distressed area" qualify for financial assistance under Section 874 of the New York State General Municipal Law) are eligible.
- Final determination of eligibility under Article 18-A of the New York State General Municipal Law shall be made by the IDA.
- An Eligible Business must not have filed a challenge to the taking of its real estate by eminent domain as "Not in the Public Good."
- The Eligible Business must be in negotiation for, under contract to, or be within 90 days of having acquired a replacement facility (the "Replacement Property"). The Replacement Property must be located in Oneida County.

Application:



- Financial assistance is conditioned upon Applicant maintaining, at a minimum, for ten years in the Replacement Property, the number of FTE employees that the Applicant employed in the "Project Zone" in 2017.
- Applicants will be subject to the recapture policy established by the IDA.
- Reduced benefits will apply if applicant no longer exclusively occupies the Replacement Property.

Deviations:

- The IDA reserves the right, at its sole discretion, to deviate from this Policy on a case-by-case basis, and will grant financial assistance to match a commitment by an Eligible Business to make an investment into and/or create employment at the Replacement Property.
- The IDA will provide written notice to each affected tax jurisdiction of any deviation from this Policy and will comply with the deviation requirement of the General Municipal Law.
- In addition to the other deviation criteria described in the IDA's Uniform Tax Exemption Policy, the IDA will consider the following to determine when it is appropriate to deviate from this policy:
  - ❖ If the Applicant commits to not only retain, but also to create, a significant number of additional permanent, private employees (FTEs) as a result of acquiring the Replacement Property.
  - ❖ If the Applicant commits to make an investment into improving the Replacement Property that exceeds expenses of relocating to the Replacement Property.
  - ❖ Consideration will be given to limiting the Base Tax to an equivalent tax based on an assessment equalization of the arms-length purchase price of the Replacement Property.

Duration of Policy:

- Three years from the date of implementation.



**ATTACHMENT  
TO OCIDA APPLICATION FOR FINANCIAL ASSISTANCE**

**Part I: Applicant Information**

**Business Description**

**5(a) Explain your project in detail.**

Location.

Central Utica Building, LLC ("CUB") proposes to construct an approximately 70,000-80,000 square foot medical office building (the "MOB") at 601 State Street (corner of State and Columbia Streets) on approximately 2.9 acres of land adjacent to, and within the footprint of the new Wynn Hospital of the Mohawk Valley Health System (the "Wynn Hospital"). CUB seeks to locate the MOB and appurtenant facilities including parking areas on the following four parcels located in Utica and adjacent to the Wynn Hospital 318.041-2-37, 318.041-2-38, 318.041-2-39 and 318.041-2-40. The MOB will be located on parcel 318.041-2-37 and parking necessary to support the MOB will be located on the remaining three parcels.

Parcels 318.041-2-37, 318.041-2-39 and 318.041-2-40 are owned by Mohawk Valley Health System ("MVHS") and will be ground-leased to CUB pursuant to a ground lease with a term of 99 years. To accommodate the MOB's parking requirements the property located at 411 Columbia Street, tax map number 318.041-2-38 (the "O'Brien Parcel") must be included in the MOB's property assemblage. Otherwise, the MOB project cannot go forward.

A copy of the concept plan showing the location of the MOB and parking areas and an excerpt from a tax map showing the proposed property assemblage are attached.

Principal Tenants. The principal tenants of the MOB and their proposed activities are as follows:

Central New York Cardiology, P.C.

Central New York Cardiology, P.C. ("CNYC") is the largest cardiology group in the region and provides general cardiology, interventional cardiology and electrophysiology services to the community drawing patients from within and outside Oneida County. CNYC cardiologists will perform interventional cardiology services at the Wynn Hospital and will take cardiology call and provide cardiology services to patients admitted to the Wynn Hospital. CNYC will occupy and build-out an approximately 20,000 square foot state-of-the-art medical office to include office space for 17 cardiologists and 11 advance practice providers. The build-out and equipping of the CNYC office is part of this Application. The office will also house sophisticated diagnostic testing capabilities including two nuclear cameras, five echocardiology labs and three vascular labs. CNYC further intends to acquire a cardiac PET scanner, which will be one of the few in the area.

CNYC has recently hired three cardiologists and support staff in anticipation of moving to a larger facility and is recruiting another cardiologist with a subspecialty of electrophysiology. The practice currently employs two electrophysiologists. There is a substantial need in the community for this subspecialty and recruiting a third electrophysiologist will significantly reduce patient wait times. CNYC's recent and planned hires are all based on the assumption that the practice will soon occupy a larger, more modern office with state-of-the-art diagnostic technologies.



CNYC currently occupies an approximately 18,000 square foot office, located on four fragmented floors in a building adjacent to St. Elizabeth's Hospital under a lease that will expire in May 2023. The space is too small, outdated and will no longer be located next to the hospital at which CNYC provides cardiology services and takes cardiology call.

#### Mohawk Valley ASC, LLC

Mohawk Valley ASC, LLC, a for-profit joint venture comprised of MVHS and local physicians, will build-out and operate an approximately 18,000 square foot, six operating room, Article 28 licensed, Medicare certified multi-specialty ambulatory surgery center. Currently, many types of surgeries and procedures previously performed in a hospital in-patient setting are migrating from hospitals to ambulatory surgery centers which provide significant cost savings to patients and payers and provide enhanced patient satisfaction.

#### Mohawk Valley Health System

MVHS will locate its Cardiac and Thoracic Surgery Group, Advanced Endoscopy clinic, Neuro-Interventional Surgery and Comprehensive Stroke Group and Imaging Center in the MOB.

Other Users. The balance of the MOB will be leased to other medical practices whose physicians practice in, and need access to the hospital and complementary non-medical uses.

#### **Reasons for Project**

##### **6(a) Please explain in detail why you want to undertake this project.**

The principal tenants of the MOB—CNYC, a 30 provider cardiology medical group servicing Oneida and surrounding counties, a six OR Medicare-certified ambulatory surgery center owned by a local physician-hospital joint venture and new MVHS specialty medical clinics and ancillary services such as lab and diagnostic radiology—will significantly enhance and expand the delivery of health care services to the community. The location of the MOB adjacent to the Wynn Hospital is critical. By being located within the Wynn Hospital footprint the MOB will enable the development of a seamless and integrated health care delivery system among the hospital and providers located in the MOB thereby improving the quality and accessibility of health care services in the community.

In addition, there is not available ambulatory surgery center capacity in the area to accommodate the volumes and types of inpatient surgical procedures that should appropriately migrate to an ambulatory surgery center setting. Ambulatory surgical centers deliver high quality surgical services at a cost significantly lower (up to 60% less) than that charged by hospitals, providing savings to patients, insurers and taxpayers. Ambulatory surgery centers also provide efficiencies and are more patient-friendly and convenient for patients. Medicare and commercial payers are driving the migration of cases from the hospital to ambulatory surgery centers. In addition, and importantly, the ambulatory surgery center will provide services to the underserved populations of Oneida and surrounding counties.

#### **Part V: Facility (Legal Information)**

**9(a)** Applicant is negotiating a 99 year ground lease for Parcels 318.041-2-37, 318.041-2-39 and 318.041-2-40 which are owned by Mohawk Valley Health System. To accommodate the MOB's parking requirements the property located at 411 Columbia Street, tax map number 318.041-2-38 (the "O'Brien Parcel") must be included in the MOB's property assemblage.

**Part V: Facility**

**9(f) Tenancies**

**Proposed MOB Tenants**

<i>Tenant</i>	<i>Approx. SF to be Occupied*</i>	<i>Business</i>
Central New York Cardiology, P.C.	20,200	Cardiology medical practice
Mohawk Valley ASC, LLC	17,595	Six OR multi-specialty Article 28 ambulatory surgery center
MVHS Cardiac and Thoracic Surgery Group	1,500	Cardiothoracic surgeons
MVHS Advanced Endoscopy Clinic	1,000	Endoscopic surgeons
MVHS Neuro-Interventional Surgery and Comprehensive Stroke Group	1,000	Brain surgery/stroke care
MVHS Imaging Center	9,870	Diagnostic radiology including CT, MRI and X-Ray
MVHS Outpatient Lab/Patient Service Center	600	Laboratory services
Dr. Qandah	2,500	Medical office
Dr. Welcons	2,500	Medical office
Medical practices (TBD)	5,000	Medical office
Coffee shop/ATM, etc	1,000	

\* This represents the actual size of the space—actual square footage. Rentable square footage will be approximately 30% greater. The sum of all rentable square footage will equal the size of the MOB.

**Part VII: Employment Information**

**11(b) Will the project preserve permanent, private sector jobs or increase the overall number of permanent private sector jobs in the State of New York?**

The project will do both. Modern health care is now acknowledged as a major economic driver for both small and large communities. Health systems are a prime source of both high technology and high paying professionals and remains a major growth industry.

CNYC has recently hired three cardiologists and support staff in anticipation of moving to a larger facility and is recruiting another cardiologist with a subspecialty of electrophysiology. The practice currently employs two electrophysiologists. There is a substantial need in the community for this subspecialty and recruiting a third electrophysiologist will significantly reduce patient wait times. CNYC's recent and planned hires are all based on the assumption that the practice will soon occupy a larger, more modern office with state-of-the-art diagnostic technologies.

Mohawk Valley ASC, LLC plans to create 9-10 FTE opportunities and will shift up to 23 FTEs from inpatient hospital ORs to the new ambulatory surgery facility. In the absence of the this surgery

center, cases traditionally performed on an in-patient basis may migrate to other lower cost settings in Oneida County or elsewhere putting these MVHS OR staff members' jobs at risk.

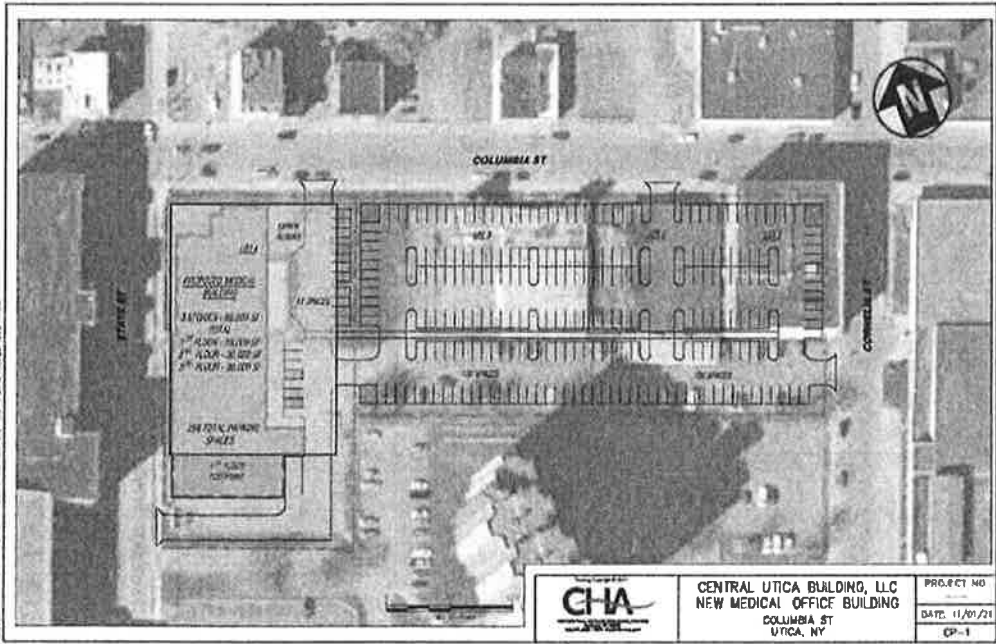

	<b>CENTRAL UTICA BUILDING, LLC</b> <b>NEW MEDICAL OFFICE BUILDING</b> COLUMBIA ST UTICA, NY	PROJECT NO.
		DATE: 11/01/21
		CP-1



**Ruberto, Laura**

---

**From:** Shawna Papale <spapale@mvedge.org>  
**Sent:** Thursday, January 06, 2022 9:59 AM  
**To:** Ruberto, Laura  
**Subject:** FW:  
**Attachments:** Central Utica Building LLC CBA.xlsx

External Email: Use caution before clicking links or opening attachments.

Shawna Papale  
Chief Administrative Officer  
Mohawk Valley EDGE  
584 Phoenix Drive  
Rome, NY 13441  
315-338-0393

**From:** Shawna Papale  
**Sent:** Monday, November 15, 2021 12:32 PM  
**To:** Dave Quirello <dquirello@cnycardiology.com>  
**Cc:** Mark Kaucher <mkaucher@mvedge.org>  
**Subject:**

David here is updated. Save as a PDF and include in app.

Shawna Papale  
Chief Administrative Officer  
Mohawk Valley EDGE  
584 Phoenix Drive  
Rome, NY 13441  
315-338-0393



**ONEIDA COUNTY INDUSTRIAL DEVELOPMENT AGENCY  
 COST/BENEFIT ANALYSIS  
 Required by §859-a(3) of the  
 New York General Municipal Law**

12-Nov-21

Name of Applicant:	Central Utica Building, LLC 601 State Street, Utica
Description of Project:	70k-80k sf medical office building Construction & equipping
Name of All Sublessees or Other Occupants of Facility:	Central NY Cardiology, PC (20k-22k sf) Mohawk Valley ASC, LLC (18k sf) MVHS (14k-17k sf)

Principals or Parent of Applicant: CNYC Realty, LLC - 30% owner  
 5DOCS, LLC - 70%

Products or Services of Applicant to be produced or carried out at facility:

Estimated Date of Completion of Project: Jul-23

Type of Financing/ Structure:

<input type="checkbox"/>	Tax-Exempt Financing
<input type="checkbox"/>	Taxable Financing
<input checked="" type="checkbox"/>	Sale/ Leaseback
<input type="checkbox"/>	Other

Type of Benefits being Sought by Applicant:

<input type="checkbox"/>	Taxable Financing
<input type="checkbox"/>	Tax-Exempt Bonds
<input checked="" type="checkbox"/>	Sales Tax Exemption on Eligible Expenses Until Completion
<input checked="" type="checkbox"/>	Mortgage Recording Tax Abatement
<input type="checkbox"/>	Real Property Tax Abatement



**Project Costs**

Land Acquisition	\$ 750,000
Existing Building(s) ACQUISITION	\$ -
Existing Building(S) RENOVATION	\$ -
NEW Building(s) CONSTRUCTION	\$ 30,868,891
Installation Costs	\$ -
Site Preparation/Parking Lot Construction	\$ 1,611,800
Machinery & Equipment (other than furniture)	\$ 6,300,000
Furniture & Fixtures	\$ -
Architectural & Engineering	\$ 735,184
Legal Fees (applicant, IDA, bank, other counsel)	\$ 100,000
Financial (all costs related to project financing)	\$ 642,954
Permits	\$ 140,000
Other	\$ 1,080,000
Agency Fee	\$ 130,572
<b>TOTAL COST OF PROJECT</b>	<b>\$ 42,359,401</b>

**Assistance Provided by the Following:**

EDGE Loan:	
MVEDD Loan:	
Grants - Please indicate source & Amount:	\$ -
Other Loans - Please indicate source & Amount:	

**Company Information**

		<b>Average Salary of these Positions</b>
Existing Jobs	148.5	\$ 130,795
Created Jobs FTE (over three years)	14.4	\$ 96,975
Retained Jobs	148.5	\$ 130,795

**Earnings Information for Onelda County**

Average Salary of Direct Jobs for Applicant	\$ 130,795
Average of County Indirect Jobs	\$ 25,000
Average of Construction Jobs	\$ 32,000

Note: \$1,000,000 in construction expenditures generates 15 person - years of employment

Construction Person Years of Employment:	162
--	-----

**Calculation of Benefits (3 Year Period)**

	Total Earnings	Revenues
Direct Jobs		
Created	\$ 4,189,320	\$ 178,046
Existing	\$ 57,484,403	\$ 2,443,087
Indirect Jobs		
Created	\$ 2,700,000	\$ 114,750
Existing	\$ 27,468,750	\$ 1,167,422
Construction - only one year		
Person Years	\$ 5,196,911	\$ 220,869
<b>TOTALS Calculation of Benefits (3 Yr Period)</b>	<b>\$ 97,039,383</b>	<b>\$ 4,124,174</b>

**TAXABLE GOODS & SERVICES**

		Spending Rate	Expenditures	State & Local Sales Tax Revenues
Direct Jobs	Created	36%	\$ 1,508,155	\$ 147,045
	Existing	0.36	\$ 20,694,385	\$ 2,017,703
Indirect Jobs	Created	0.36	\$ 972,000	\$ 94,770
	Existing	0.36	\$ 9,888,750	\$ 964,153
Construction - only one year	Person Years	0.36	\$ 1,870,888	\$ 182,412
<b>TOTAL TAXABLE GOODS &amp; SERVICES</b>			<b>\$ 34,934,178</b>	<b>\$ 3,406,082</b>

Local (3 year) real property tax benefit (assuming 60% of jobs existing and created own a residence) with an average assessment of \$80,000 and the remainder of jobs existing created pay real property taxes through rent based on an average assessment per apartment of \$50,000.

	Total Rate:	Municipality	
Tax Rate for School District where facility is located:	27.209182	Utica	21-22
Tax Rate for Municipality where facility is located:	27.03189	Utica	2021
Tax Rate for County:	12.688297	Oneida	2021
	<b>66.929369</b>		
Real Property Taxes Paid:	<b>\$ 732,288</b>		

**COSTS: IDA BENEFITS**

Real Property Taxes Abatement	\$ -
Mortgage Tax Abated (.75%)	\$ 128,138
Estimated Sales Tax Abated During Construction Period (8.75%)	\$ 1,820,000
<b>Total:</b>	<b>\$ 1,948,138</b>

NOTE: If there is a tax-exempt financing of all or a portion of the project cost, there is a neutral cost/benefit because of lower interest rates by reason of exclusion of interest from gross income of bondholders for purposes of Federal and State income taxes. Taxable financing carries the same cost/benefit for State Income Tax purposes. Such cost/benefits cannot be quantified.

Anthony J. Picente Jr,  
County Executive

Shawna M. Papale  
Secretary/ Treasurer/  
Executive Director

Jennifer Waters  
Assistant Secretary

ONEIDA COUNTY INDUSTRIAL  
DEVELOPMENT AGENCY

**OCIDA**



584 Phoenix Drive  
Rome, New York 13441-4105  
(315) 338-0393, fax (315) 338-5694

David C. Grow  
Chairman

Michael Fitzgerald  
Vice Chairman

Ferris Betrus Jr.

Kirk Hinman

Mary Faith Messenger

Eugene Quadraro

Stephen Zogby

To: Oneida County Industrial Development Agency Board of Directors  
From: Shawna M. Papale  
Date: November 15, 2021  
RE: OCIDA Meeting Agenda

The Oneida County Industrial Development Agency shall meet – 8:00 AM Friday, November 19, 2021.

Members of the public may listen to the Agency meeting by calling +1-408-418-9388, Access code: 263 390 17399 or attend in person. The Minutes of the Agency meeting will transcribed and posted on the OCIDA website.

1. Executive Session at 8:00 AM if needed
2. Approve minutes – October 21, 2021
3. Financial Review
  - a) Interim Financials
4. EDGE 2022 Contract
5. EDGE 2022 Supplemental Contract
6. Consider an inducement resolution relating to the **Central Utica Building, LLC facility**, providing preliminary approval for financial assistance in the form of exemptions from sales tax (estimated at \$1,820,000 not to exceed \$2,002,000) and exemptions from mortgage recording tax (estimated at \$128,138 not to exceed \$140,951), which financial assistance is consistent with the Agency's Uniform Tax Exemption Policy, and authorizing the Agency to conduct a public hearing. The project is considered a "retail facility" and the Agency will need to make findings at a future meeting to qualify financial assistance.
7. Consider an inducement resolution relating to the **Delta Luxury Townhomes LLC facility**, granting preliminary approval for financial assistance in the form of exemptions from sales tax (estimated at \$490,000 not to exceed \$539,000) and exemptions from mortgage recording tax (estimated at \$64,500 not to exceed \$70,950) which financial assistance is consistent with Tier 3

Anthony J. Picente Jr.  
County Executive

Shawna M. Papale  
Secretary/ Treasurer/  
Executive Director

Jennifer Waters  
Assistant Secretary

ONEIDA COUNTY INDUSTRIAL  
DEVELOPMENT AGENCY

**OCIDA**



584 Phoenix Drive  
Rome, New York 13441-4105  
(315) 338-0393, fax (315) 338-5694

David C. Grow  
Chairman

Michael Fitzgerald  
Vice Chairman

Ferris Betrus Jr.

Kirk Hinman

Mary Faith Messenger

Eugene Quadraro

Stephen Zogby

benefits under the Agency's Uniform Tax Exemption Policy (Housing Policy) and authorizing the Agency to conduct a public hearing.

8. Consider a SEQR resolution relating to the **Delta Luxury Townhomes LLC facility**. The City of Rome Planning Board acted as lead agency for the SEQR review and determined on July 8, 2021 that the project is a Type 1 action.
9. Consider a final authorizing resolution relating to the **Parco Properties, Inc./The Fountainhead Group, Inc. facility**, approving financial assistance in the form of exemptions from sales tax (estimated at \$97,475 but not to exceed \$107,222) and reduction of real property tax for a period of ten years, during which time the Company will pay PILOT Payments equal to the current taxes (estimated at \$203,000), which financial assistance is a deviation from the Agency's Uniform Tax Exemption Policy, and authorizing the form and execution of related documents in the Agency's customary form and subject to counsel review. The Agency conducted a public hearing on August 26, 2021 and mailed deviation notices to the affected tax jurisdictions on November 10, 2021.
10. Consider a request from **Cold Point Corporation** to amend an existing sales tax exemption to (i) extend the time for an additional one year through May 18, 2022 and (ii) increase the value of the exemption from \$144,683 to \$188,870, a difference of \$44,187. A public hearing is not required as the value of the additional financial assistance does not exceed \$100,000.
11. Consider a request from **GSPP 7024 Fox Rd., LLC (Marcy Community Solar Project)** to consent to a change of control to (i) the transfer of 100% of the Company's equity voting interest from GSPP CM Panel, LLC to GSPP Holdco, LLC and (ii) the transfer of 100% of the equity voting interest from GSPP Holdco, LLC to GSPP CB 2021 Master Lessor, LLC, which is contemplated to occur upon mechanical completion of the Project, and authorize the form and execution of related documents subject to counsel review.
12. Consider a request from **GSPP Hillsboro & Dunbar, LLC (Camden Community Solar Project)** to amend previously authorized financial assistance in the form of reduction of real property taxes for a period of 25 years (value estimated at \$1,729,030), consistent with the Agency's Uniform Tax Exemption Policy (Community Solar Policy) and authorizing the Agency to conduct a public hearing. The Agency adopted a final authorizing resolution on October 23, 2020 approving financial assistance for the project consistent with the Community Solar Policy that was adopted in September 2020. The applicant is requesting the financial assistance be revised to be consistent with the amended Community Solar Policy that was adopted in April 2021. GIS Mapping confirms the land is classified as Farmland of Statewide Importance and the \$5,500 per MW rate applies. The applicant has submitted a decommission plan and decommissioning bond that has been approved by the Host Community.

Anthony J. Picente Jr.  
County Executive

Shawna M. Papale  
Secretary/ Treasurer/  
Executive Director

Jennifer Waters  
Assistant Secretary

ONEIDA COUNTY INDUSTRIAL  
DEVELOPMENT AGENCY

**OCIDA**



584 Phoenix Drive  
Rome, New York 13441-4105  
(315) 338-0393, fax (315) 338-5694

David C. Grow  
Chairman

Michael Fitzgerald  
Vice Chairman

Ferris Betrus Jr.  
Kirk Hinman

Mary Falth Messenger

Eugene Quadraro  
Stephen Zogby

### 13. Old Business

Next meeting date – **Friday, December 17, 2021** at 8 AM at 584 Phoenix Drive, Rome, NY

**From:** [Bruce A. Smith](#)  
**To:** [Shawna Pagale](#)  
**Cc:** [Linda Romano \(lromano@bsk.com\)](#); [Ruberto, Laura](#); [David Quirello \(dquirello@cnycardiology.com\)](#)  
**Subject:** Letter supplementing OCIDA application  
**Date:** Thursday, November 18, 2021 3:53:15 PM  
**Attachments:** [Nov 18 supplement letter to OCIDA.pdf](#)

---

Bruce A. Smith, Esq.  
Cohen Compagni Beckman Appler & Knoll, PLLC  
507 Plum Street, Suite 310  
Syracuse, New York 13204  
Direct Phone: (315) 477-6291  
Direct Fax: (315) 425-3691  
E-mail: [bsmith@ccbllaw.com](mailto:bsmith@ccbllaw.com)  
Website: [www.ccbllaw.com](http://www.ccbllaw.com)

**This electronic transmission contains information from the law firm of Cohen Compagni Beckman Appler & Knoll, PLLC, which is confidential, covered by the attorney-client privilege, and solely for the person or entity named above. If you are not the intended recipient, be aware that any disclosure, copying, distribution or use of this information is prohibited. If you have received this electronic mail transmission in error, please notify us by telephone, mail or electronic mail and destroy this communication.**

CAUTION: This email originated from outside of the organization. Do not click links or open attachments unless you recognize the sender and know the content is safe.







**Bruce A Smith**  
Direct: 315.477.6291  
Direct Fax: 315.425.3691  
Email: bsmith@ccblaw.com

November 18, 2021

BY E-MAIL

Shawna M. Papale, Executive Director  
Oneida County Industrial Development Agency  
584 Phoenix Drive  
Rome, New York 13441

Re: Central Utica Building Project

Dear Ms. Papale:

This purpose of this letter is to supplement Central Utica Building, LLC's ("CUB") response to Part IV: Retail Project Questionnaire in its Application for Financial Assistance previously submitted to OCIDA. As you know, the project will be located in a distressed area which will permit OCIDA to provide financial assistance to the project under the General Municipal Law. CUB checked "No" to the questions in Section 8(b)(1) and (2) of Part IV because neither CUB nor the principal occupants of the medical office building ("MOB") had obtained—or felt the need to obtain—a third party analysis as referenced in the instructions for those two questions. However, as noted below, CUB believes that project would satisfy the criteria listed in both questions.

The medical specialties that will occupy the MOB—including cardiology, cardiothoracic surgery, brain surgery/stroke and diagnostic imaging—all draw a significant number of patients from areas outside of Oneida County. The new multi-specialty ambulatory surgery center will be expected to do the same.

The proposed ambulatory surgery center—which will be owned by a physician-hospital joint venture—will have six operating rooms and will be designed and equipped to be state-of-the-art. Much of the outpatient surgery volume currently performed at St. Elizabeth's and St. Luke's hospitals will move to the surgery center. In addition, many types of surgeries currently performed in a hospital in-patient setting are migrating to ambulatory surgery centers which provide significant cost savings to patients and payers. There is not sufficient ambulatory surgery center capacity in Oneida County to handle the projected case volume. Therefore, this new six OR ambulatory surgery center will be a needed addition to the area's health care community.

**COHEN COMPAGNI BECKMAN APPLER & KNOLL, PLLC**  
Attorneys and Counselors at Law  
507 Plum Street, Suite 310, Syracuse, New York 13204  
Phone: 315.671.6000 • Fax: 315.671.6001 • Web: www.ccblaw.com



Page 2

Overall, this project will significantly enhance and/or expand the delivery of health care services to the community. The location of the MOB adjacent to the Wynn Hospital will enable the development of a seamless and integrated health care delivery system among the Wynn Hospital and providers located in the MOB thereby improving the quality and accessibility of health care services in the community.

Very truly yours,

*Bruce A. Smith*

Bruce A. Smith

**Minutes of the Meeting of the  
Oneida County Industrial Development Agency  
November 19, 2021**

**In person at 584 Phoenix Drive, Rome, NY and Webex Video/Teleconference**

**Members Present:** David Grow; L. Michael Fitzgerald; Steve Zogby; Kirk Hinman; Eugene Quadraro.

**Members Present Webex/Teleconference:** Ferris Betrus.

**EDGE Staff Present:** Shawna Papale; Jennifer Waters; Mark Kaucher; Steven J. DiMeo; Bill Van Shufflin; Maureen Carney; Tim Fitzgerald.

**Others Present:** Rome Mayor Jackie Izzo; Bob Scholefield, Mohawk Valley Health System; Bruce Smith, Cohen Compagni Beckman Appler & Knoll, PLLC; Dave Quirillo, Central Utica Building

**Others Present Webex/Teleconference:** Laura Ruberto and Linda Romano, Bond, Schoeneck & King; Mark Levitt and Jenna Peppenelli, Levitt & Gordon; Genevieve Trigg, Barclay Damon.

Chair Grow called the meeting to order at 8:03 AM.

**Executive Session:** Chair Grow asked if there were any requests for Executive Session. At 8:03 AM, S. Zogby motioned to enter executive session to discuss pending contracts and possible litigation matters. M. Fitzgerald seconded the motion, which carried 6-0.

At 9:02 AM, a motion to exit executive session and return to the open meeting was moved by E. Quadraro, seconded by F. Betrus, and carried 6-0.

**Minutes:** The October 21, 2021 meeting minutes were reviewed. M. Fitzgerald pointed out the incorrect date in the heading of the minutes. T. Fitzgerald stated that the language regarding the lease renewal to Rome Community Brownfield Restoration Corporation needed to be revised to state that the lease agreement will use the Agency's current form. A motion to approve the minutes as corrected was moved by S. Zogby, seconded by E. Quadraro and carried 6-0.

**EDGE 2022 Contract and Supplemental Contract**

Chair Grow presented for the Agency's consideration, the proposed 2022 Mohawk Valley EDGE Staff Service Contract and Supplemental Staff Service Contract. With no comments or questions, F. Betrus moved to approve both the 2022 Mohawk Valley EDGE Staff Service Contract and Supplemental Staff Service Contract, as presented. K. Hinman seconded the motion, which then carried 6-0.

M. Fitzgerald reminded the Agency that after the previous meeting, staff was going to evaluate the time and effort associated with change in ownership activities that come before the Agency, in anticipation of more such activity occurring as the Agency takes on more solar projects. M. Fitzgerald moved to increase the fee for handling such requests from \$500 to \$2,500. The motion was seconded by E. Quadraro and was passed unanimously.

**Parco Properties, Inc./The Fountainhead Group, Inc.**

Chair Grow introduced a final authorizing resolution relating to the Parco Properties, Inc./The Fountainhead Group, Inc. facility, approving financial assistance in the form of exemptions from sales tax (estimated at \$97,475 but not to exceed \$107,222) and reduction of real property tax for a period of ten years, during which time the Company will pay PILOT Payments equal to the current taxes (estimated at \$203,000), which financial assistance is a deviation from the Agency's Uniform Tax Exemption Policy, and authorizing the form and execution of related documents in the Agency's customary form and subject to counsel review. The Agency conducted a public hearing on August 26, 2021 and mailed deviation notices to the affected tax jurisdictions on November 10, 2021. Chair Grow pointed out that no comments were received from the affected taxing jurisdictions. A motion to approve the final authorizing resolution relating to the Parco Properties, Inc./The Fountainhead Group, Inc. facility was moved by S. Zogby and seconded by M. Fitzgerald. F. Betrus

asked for clarification if a 2% yearly escalator was included in the proposed benefit. Both M. Kaucher and S. Papale stated that there was, but that the current taxes are locked in for 10 years. **S. Zogby amended his motion so that it would be consistent with the annual increases outlined in the original inducement resolution. M. Fitzgerald concurred. With no further discussion, the motion carried, 6-0.**

#### **Cold Point Corporation**

Chair Grow introduced a request from Cold Point Corporation to amend an existing sales tax exemption to (i) extend the time for an additional one year through May 18, 2022 and (ii) increase the value of the exemption from \$144,683 to \$188,870, a difference of \$44,187. A public hearing is not required as the value of the additional financial assistance does not exceed \$100,000. **M. Fitzgerald moved to approve the request from Cold Point Corporation to both extend its sales tax exemption period and increase the value of its exemption, as proposed. The motion was seconded by K. Hinman and was passed unanimously.**

#### **GSPP 7024 Fox Rd., LLC (Marcy Community Solar Project)**

Chair Grow introduced a request from GSPP 7024 Fox Rd., LLC (Marcy Community Solar Project) to consent to a change of control to (i) the transfer of 100% of the Company's equity voting interest from GSPP CM Panel, LLC to GSPP Holdco, LLC and (ii) the transfer of 100% of the equity voting interest from GSPP Holdco, LLC to GSPP CB 2021 Master Lessor, LLC, which is contemplated to occur upon mechanical completion of the Project, and authorize the form and execution of related documents subject to counsel review. **S. Zogby moved to approve the request from GSPP 7024 Fox Rd., LLC to consent to changes of control, as proposed. The motion was seconded by M. Fitzgerald and passed 6-0.** M. Fitzgerald that this action will be subject to the new fee schedule, which was just approved.

#### **GSPP Hillsboro & Dunbar, LLC (Camden Community Solar Project)**

Chair Grow introduced a request from GSPP Hillsboro & Dunbar, LLC (Camden Community Solar Project) to amend previously authorized financial assistance in the form of reduction of real property taxes for a period of 25 years (value estimated at \$1,729,030), consistent with the Agency's Uniform Tax Exemption Policy (Community Solar Policy) and authorizing the Agency to conduct a public hearing. The Agency adopted a final authorizing resolution on October 23, 2020 approving financial assistance for the project consistent with the Community Solar Policy that was adopted in September 2020. The applicant is requesting the financial assistance be revised to be consistent with the amended Community Solar Policy that was adopted in April 2021. GIS Mapping confirms the land is classified as Farmland of Statewide Importance and the \$5,500 per MW rate applies. The applicant has submitted a decommission plan and decommissioning bond that has been approved by the Host Community. **E. Quadraro moved to approve the request from GSPP Hillsboro & Dunbar, LLC to consent to changes to financial assistance, as proposed and authorizing the Agency to conduct a public hearing. The motion was seconded by S. Zogby and passed 6-0**

#### **Central Utica Building, LLC**

Chair Grow introduced an inducement resolution relating to the Central Utica Building, LLC facility, providing preliminary approval for financial assistance in the form of exemptions from sales tax (estimated at \$1,820,000 not to exceed \$2,002,000) and exemptions from mortgage recording tax (estimated at \$128,138 not to exceed \$140,951), which financial assistance is consistent with the Agency's Uniform Tax Exemption Policy, and authorizing the Agency to conduct a public hearing. The project is considered a "retail facility" and the Agency will need to make findings at a future meeting to qualify financial assistance. S. Zogby stated that the proposed benefit seems high, given that Mohawk Valley Health System will only occupy 25-30% of the building, according to the information provided. As such, he would be comfortable with reducing and limiting the financial benefit. **M. Fitzgerald made a motion to approve a benefit to Central Utica Building, LLC not to exceed \$500,000 in sales tax exemption and not to exceed \$140,951 in mortgage recording tax exemption. S Zogby seconded this motion.** Chair Grow then noted that the Agency has been supportive of the MVHS hospital project since its inception, and that this proposed benefit aligns with that support by benefitting this project commensurate with the level of MVHS building occupation. B. Scholefield stated that according to the application, MVHS will be utilizing about 25% of the proposed building. B. Scholefield then stated that ambulatory surgical centers, such as the one MVHS is proposing to put in this building, are handling more and more surgeries as a trend nationwide, and that this project would help build the capacity of such surgical space in Oneida County. F. Betrus

asked if this building will be connected to the hospital. B. Scholefield stated that they would not be connected, and that generally speaking, the traffic between these buildings will generally be low, limited to doctors and staff. With no further discussion, the motion passed 6-0.

#### Delta Luxury Townhomes LLC

Chair Grow introduced an inducement resolution relating to the Delta Luxury Townhomes LLC facility, granting preliminary approval for financial assistance in the form of exemptions from sales tax (estimated at \$490,000 not to exceed \$539,000) and exemptions from mortgage recording tax (estimated at \$64,500 not to exceed \$70,950) which financial assistance is consistent with Tier 3 benefits under the Agency's Uniform Tax Exemption Policy (Housing Policy) and authorizing the Agency to conduct a public hearing. M. Fitzgerald made an amended motion, such that the sales tax benefit will be the lesser of what's incurred within two years of the inducement date, or \$490,000, and cannot exceed the lesser amount. K. Hinman seconded the motion. M. Fitzgerald asked Mayor Izzo to explain the ongoing need for new housing in Rome, which this project seeks to satisfy. Mayor Izzo explained that townhomes are a segment of the area's housing stock that is very limited, and this project addresses this need, which is identified in the applicant's market study. With no further discussion, the motion passed 6-0.

#### Delta Luxury Townhomes LLC – SEQR Resolution

Chair Grow introduced a SEQR resolution relating to the Delta Luxury Townhomes LLC facility. The City of Rome Planning Board acted as lead agency for the SEQR review and determined on July 8, 2021 that the project is a Type 1 action. Mayor Izzo stated that the City Planning Board has given the project a negative declaration on the SEQR. She also stated that, in connection to this project, the City plans to replace the bridge crossing over the Wood Creek at Merrick Rd. A motion to accept the SEQR findings related to the Delta Luxury Townhomes LLC project was moved by F. Betrus, seconded by S. Zogby, and carried 6-0.

#### Financial Report

M. Carney reviewed the interim financial statements from October 31, 2021. She stated that the Agency had closed on its projects with EDF Renewables 2 and Square One Coating Systems in October. These closings resulted in over \$54,000 in administrative closing fees paid to the Agency. Overall, there has been an increase in cash of over \$194,000 over the last twelve months. She also noted that the project with Engler Electric closed during the month of November.

S. Zogby asked if the Agency was on track to close several more projects by the year's end, which S. Papale confirmed. She also stated that there usually is an uptick in project closings at the end of each year.

The financial report was accepted as presented.

There being no further business, Chair Grow asked for a resolution to adjourn the meeting. At 9:32 AM a motion to adjourn the meeting was moved by S. Zogby, seconded by M. Fitzgerald, and carried unanimously.

Respectfully Submitted,

Tim Fitzgerald

**From:** [Dave Quirello](#)  
**To:** [Ruberto, Laura](#); ["Bruce A. Smith"](#); [Shawna Papale](#); [Mark Kaucher](#)  
**Cc:** ["Romano, Linda"](#)  
**Subject:** RE: Central Utica Building, LLC/Oneida County IDA  
**Date:** Friday, November 19, 2021 4:22:49 PM  
**Attachments:** [image001.png](#)

---

Laura,

The "Facility" description seems acceptable to me. Bruce, comments?

David Quirello, CMPE  
Chief Financial Officer



**Central New York Cardiology**

2211 Genesee Street  
Utica NY 13501  
Phone: (315) 733-7598 ext. 2236  
Fax: (315) 733-7694  
[dquirello@cnycardiology.com](mailto:dquirello@cnycardiology.com)

**From:** Ruberto, Laura [<mailto:RubertL@bsk.com>]  
**Sent:** Friday, November 19, 2021 12:46 PM  
**To:** Bruce A. Smith <[bsmith@ccblaw.com](mailto:bsmith@ccblaw.com)>; David Quirello ([dquirello@cnycardiology.com](mailto:dquirello@cnycardiology.com)) <[dquirello@cnycardiology.com](mailto:dquirello@cnycardiology.com)>; 'Shawna Papale' <[spapale@mvedge.org](mailto:spapale@mvedge.org)>; Mark Kaucher <[mkaucher@mvedge.org](mailto:mkaucher@mvedge.org)>  
**Cc:** Romano, Linda <[romanol@bsk.com](mailto:romanol@bsk.com)>  
**Subject:** Central Utica Building, LLC/Oneida County IDA

Good afternoon; following this morning's meeting and project inducement, we drafted the attached legal notice to allow the Agency to conduct a public hearing. We ask that you please confirm the accuracy of the description of the "Facility" as all financial assistance will be limited to what is contained in this notice.

**Shawna/Mark**, would you please suggest some dates to conduct the hearing? If we submit for publication early next week, the hearing can be held any time after December 6. Please also advise a location within the City of Utica where the hearing can be conducted. A representative of the Company will be asked to attend the hearing.

We are drafting the rest of the inducement documents but wanted to circulate the legal notice in the interim so the IDA can proceed with the public hearing. Please advise if any other parties should be included in the working group.

Best,  
Laura

**Laura S. Ruberto**

Paralegal  
Business  
315.738.1223 Direct  
315.724.2074 Fax  
[lruberto@bsk.com](mailto:lruberto@bsk.com)

501 Main Street, Utica, NY 13501-1245

This email is ONLY for the person(s) named in the message header. Unless otherwise indicated, it contains information that is confidential, privileged or exempt from disclosure under applicable law. If you have received it in error, please notify the sender of the error and delete the message.

IRS regulations require us to notify you that any tax advice contained in this communication (including any attachments) is not intended or written to be used, and cannot be used, for the purpose of avoiding penalties under the Internal Revenue Code. If you want a further description of this requirement, go to <https://www.bsk.com/disclaimer>.

**CAUTION: This email originated from outside of the organization. Do not click links or open attachments unless you recognize the sender and know the content is safe.**

**From:** [Dave Quirello](#)  
**To:** [Mark Kaucher](#); "[Bruce A. Smith](#)"; [Ruberto, Laura](#); [Shawna Papale](#)  
**Cc:** "[Romano, Linda](#)"  
**Subject:** RE: Central Utica Building, LLC/Onelda County IDA  
**Date:** Friday, November 19, 2021 4:19:00 PM  
**Attachments:** [image001.png](#)

---

Mark,

No preference on the date. 10 works well.

Thanks

David Quirello, CMPE  
Chief Financial Officer



Central New York Cardiology

2211 Genesee Street

Utica NY 13501

Phone: (315) 733-7598 ext. 2236

Fax: (315) 733-7694

[dquirello@cnycardiology.com](mailto:dquirello@cnycardiology.com)

**From:** Mark Kaucher [<mailto:mkaucher@mvedge.org>]

**Sent:** Friday, November 19, 2021 4:14 PM

**To:** Bruce A. Smith <[bsmith@ccblaw.com](mailto:bsmith@ccblaw.com)>; Ruberto, Laura <[rubertl@bsk.com](mailto:rubertl@bsk.com)>; David Quirello ([dquirello@cnycardiology.com](mailto:dquirello@cnycardiology.com)) <[dquirello@cnycardiology.com](mailto:dquirello@cnycardiology.com)>; Shawna Papale <[spapale@mvedge.org](mailto:spapale@mvedge.org)>

**Cc:** Romano, Linda <[romanol@bsk.com](mailto:romanol@bsk.com)>

**Subject:** RE: Central Utica Building, LLC/Oneida County IDA

Bruce has advised that either day is ok with him. David, do you have any preference between Thursday, December 9<sup>th</sup> or Friday, December the 10<sup>th</sup>?

**Mark F. Kaucher, V. P. Economic Development**

Mohawk Valley EDGE

584 Phoenix Drive, Rome, NY 13441

(315) 338-0393/Office (315) 271-7276/cell

(315) 338-5694/Fax [mkaucher@mvedge.org](mailto:mkaucher@mvedge.org)

**From:** Mark Kaucher

**Sent:** Friday, November 19, 2021 3:14 PM

**To:** Bruce A. Smith <[bsmith@ccblaw.com](mailto:bsmith@ccblaw.com)>; Ruberto, Laura <[rubertl@bsk.com](mailto:rubertl@bsk.com)>; David Quirello ([dquirello@cnycardiology.com](mailto:dquirello@cnycardiology.com)) <[dquirello@cnycardiology.com](mailto:dquirello@cnycardiology.com)>; Shawna Papale



<[spapale@mvedge.org](mailto:spapale@mvedge.org)>

**Cc:** Romano, Linda <[romanol@bsk.com](mailto:romanol@bsk.com)>

**Subject:** RE: Central Utica Building, LLC/Oneida County IDA

Thank you Bruce. We are planning to change the venue to the Oneida County Legislative Chambers at the Oneida County Office Building. Do you have a preference for either day as both are available?

**Mark F. Kaucher, V. P. Economic Development**

Mohawk Valley EDGE

584 Phoenix Drive, Rome, NY 13441

(315) 338-0393/Office (315) 271-7276/cell

(315) 338-5694/Fax [mkaucher@mvedge.org](mailto:mkaucher@mvedge.org)

**From:** Bruce A. Smith <[bsmith@ccblaw.com](mailto:bsmith@ccblaw.com)>

**Sent:** Friday, November 19, 2021 3:10 PM

**To:** Mark Kaucher <[mkaucher@mvedge.org](mailto:mkaucher@mvedge.org)>; Ruberto, Laura <[rubertl@bsk.com](mailto:rubertl@bsk.com)>; David Quirello (<[dquirello@cnycardiology.com](mailto:dquirello@cnycardiology.com)> <[dquirello@cnycardiology.com](mailto:dquirello@cnycardiology.com)>); Shawna Papale <[spapale@mvedge.org](mailto:spapale@mvedge.org)>

**Cc:** Romano, Linda <[romanol@bsk.com](mailto:romanol@bsk.com)>

**Subject:** RE: Central Utica Building, LLC/Oneida County IDA

Fine by me

Bruce A. Smith, Esq.

Cohen Compagni Beckman Appler & Knoll, PLLC

507 Plum Street, Suite 310

Syracuse, New York 13204

Direct Phone: (315) 477-6291

Direct Fax: (315) 425-3691

E-mail: [bsmith@ccblaw.com](mailto:bsmith@ccblaw.com)

Website: [www.ccblaw.com](http://www.ccblaw.com)

**This electronic transmission contains information from the law firm of Cohen Compagni Beckman Appler & Knoll, PLLC, which is confidential, covered by the attorney-client privilege, and solely for the person or entity named above. If you are not the intended recipient, be aware that any disclosure, copying, distribution or use of this information is prohibited. If you have received this electronic mail transmission in error, please notify us by telephone, mail or electronic mail and destroy this communication.**

**From:** Mark Kaucher <[mkaucher@mvedge.org](mailto:mkaucher@mvedge.org)>

**Sent:** Friday, November 19, 2021 2:05 PM

**To:** Ruberto, Laura <[rubertl@bsk.com](mailto:rubertl@bsk.com)>; Bruce A. Smith <[bsmith@ccblaw.com](mailto:bsmith@ccblaw.com)>; David Quirello (<[dquirello@cnycardiology.com](mailto:dquirello@cnycardiology.com)> <[dquirello@cnycardiology.com](mailto:dquirello@cnycardiology.com)>); Shawna Papale <[spapale@mvedge.org](mailto:spapale@mvedge.org)>

**Cc:** Romano, Linda <[romanol@bsk.com](mailto:romanol@bsk.com)>

**Subject:** RE: Central Utica Building, LLC/Oneida County IDA

th

th

How would 10 AM on either Thursday December 9 or Friday December 10 work for everyone? Historically, past OCIDA projects within the City of Utica have been held in the Common Council Chambers within City Hall.

Thank you.

**Mark F. Kaucher, V. P. Economic Development**

Mohawk Valley EDGE

584 Phoenix Drive, Rome, NY 13441

(315) 338-0393/Office (315) 271-7276/cell

(315) 338-5694/Fax [mkaucher@mvedge.org](mailto:mkaucher@mvedge.org)

**From:** Ruberto, Laura <[RubertL@bsk.com](mailto:RubertL@bsk.com)>

**Sent:** Friday, November 19, 2021 12:46 PM

**To:** Bruce A. Smith <[bsmith@cchlaw.com](mailto:bsmith@cchlaw.com)>; David Quirello ([dquirello@cnycardiology.com](mailto:dquirello@cnycardiology.com)) <[dquirello@cnycardiology.com](mailto:dquirello@cnycardiology.com)>; Shawna Papale <[spapale@mvedge.org](mailto:spapale@mvedge.org)>; Mark Kaucher <[mkaucher@mvedge.org](mailto:mkaucher@mvedge.org)>

**Cc:** Romano, Linda <[romanoi@bsk.com](mailto:romanoi@bsk.com)>

**Subject:** Central Utica Building, LLC/Oneida County IDA

Good afternoon; following this morning's meeting and project inducement, we drafted the attached legal notice to allow the Agency to conduct a public hearing. We ask that you please confirm the accuracy of the description of the "Facility" as all financial assistance will be limited to what is contained in this notice.

**Shawna/Mark**, would you please suggest some dates to conduct the hearing? If we submit for publication early next week, the hearing can be held any time after December 6. Please also advise a location within the City of Utica where the hearing can be conducted. A representative of the Company will be asked to attend the hearing.

We are drafting the rest of the inducement documents but wanted to circulate the legal notice in the interim so the IDA can proceed with the public hearing. Please advise if any other parties should be included in the working group.

Best,  
Laura

**Laura S. Ruberto**

Paralegal

Business

315.738.1223 Direct

315.724.2074 Fax

[lruberto@bsk.com](mailto:lruberto@bsk.com)

\_\_\_\_\_

501 Main Street, Utica, NY 13501-1245

This email is ONLY for the person(s) named in the message header. Unless otherwise indicated, it contains information that is confidential, privileged or exempt from disclosure under applicable law. If you have received it in error, please notify the sender of the error and delete the message.

IRS regulations require us to notify you that any tax advice contained in this communication (including any attachments) is not intended or written to be used, and cannot be used, for the purpose of avoiding penalties under the Internal Revenue Code. If you want a further description of this requirement, go to <https://www.bsk.com/disclaimer>.

**CAUTION: This email originated from outside of the organization. Do not click links or open attachments unless you recognize the sender and know the content is safe.**

**CAUTION: This email originated from outside of the organization. Do not click links or open attachments unless you recognize the sender and know the content is safe.**

**CAUTION: This email originated from outside of the organization. Do not click links or open attachments unless you recognize the sender and know the content is safe.**

## NOTICE OF PUBLIC HEARING

NOTICE IS HEREBY GIVEN that a public hearing pursuant to Article 18-A of the New York State General Municipal Law, will be held by the Oneida County Industrial Development Agency (the "Agency") on the \_\_\_\_\_ day of December 2021 at \_\_\_\_\_ a.m., local time, at \_\_\_\_\_, City of Utica, New York in connection with the following matters:

Central Utica Building, LLC, on behalf of itself and/or the principals of Central Utica Building, LLC, and/or an entity formed or to be formed on behalf of any of the foregoing (collectively, the "Company") has applied to the Oneida County Industrial Development Agency (the "Agency") to enter into a transaction in which the Agency will assist in the construction of an 80,000± square foot state-of-the-art medical office building and appurtenant facilities including parking areas and all infrastructure, utilities and amenities to support the same (collectively, the "Improvements") situated on four parcels of land measuring 2.90± acres in the aggregate adjacent to the new Wynn Hospital (the "Wynn Hospital") located at 601 State Street (Corner of State and Columbia Streets), City of Utica, Oneida County, New York (the "Land") and acquisition and installation of equipment in the Improvements (the "Equipment"), all for the purpose of providing a seamless and integrated health care delivery system together with the Wynn Hospital, and to enhance and expand the delivery of health care services to the community (the Land, the Improvements and the Equipment are referred to collectively as the "Facility" and the construction and equipping of the Improvements is referred to as the "Project"). The Facility will be initially operated and/or managed by the Company.

The Company will lease the Facility to the Agency, and the Agency will lease the Facility back to the Company pursuant to a leaseback agreement. At the end of the lease term, the Agency will terminate its leasehold interest in the Facility. The Company will sublease a 20,000± square foot portion of the Facility to Central New York Cardiology, P.C. (the "CNYC Sublessee") for its operation for the purpose of performing interventional cardiology services at the Wynn Hospital, to take cardiology call and provide cardiology services to patients admitted to the Wynn Hospital. The Company will sublease an 18,000± square foot portion of the Facility to Mohawk Valley ASC, LLC (the "MVASC Sublessee") for its operation for the purpose of operating an Article 28 licensed, Medicare certified multi-specialty ambulatory surgery center with six operating rooms. The Company will sublease other portions of the Facility to MVHS and other medical practices whose physicians practice in, and need access to, the Wynn Hospital, and to other commercial and/or retail tenants to provide complementary services (such sublessees, together with the CNYC Sublessee and the MVASC Sublessee, are referred to collectively as the "Sublessees").

The Agency is contemplating providing financial assistance in the form of exemptions from mortgage recording taxes and exemptions from sales tax on materials and equipment acquired and installed in connection with the Project, such sales tax exemptions to be limited to \$500,000.00, which financial assistance is a deviation from the Agency's Uniform Tax Exemption Policy, to be more particularly described in a Final

Authorizing Resolution to be adopted by the Agency prior to the closing of the transactions described herein. Such financial assistance will be conditioned upon the Company creating, retaining and maintaining (or causing the Sublessees to create, retain and maintain) certain employment at the Facility as a result of undertaking the Project.

A representative of the Agency will at the above-stated time and place hear and accept written comments from all persons with views in favor of or opposed to either the proposed financial assistance to the Company or the location or nature of the Facility. Comments may also be submitted to the Agency in writing or electronically prior to the Public Hearing. Members of the public may also access the Public Hearing and comment on the Project and the benefits to be granted to the Applicant by the Agency during the Public Hearing by calling 1-408-418-9388 (Access code: \_\_\_\_\_). Minutes of the Public Hearing will be transcribed and posted on the Agency's website. A copy of the Application for Financial Assistance filed by the Company with the Agency, including an analysis of the costs and benefits of the proposed Project, is available for public inspection at the offices of the Agency, 584 Phoenix Drive, Rome, New York.

ONEIDA COUNTY INDUSTRIAL  
DEVELOPMENT AGENCY

Dated: November 19, 2021

By: /s/ Shawna M. Papale, Executive Director

**Ruberto, Laura**

---

**From:** Gannett Legals Public Notices 4 <ganlegpubnotices4@gannett.com>  
**Sent:** Monday, November 22, 2021 12:08 PM  
**To:** Ruberto, Laura  
**Subject:** RE: 6567845 legal notice: Central Utica Building, LLC  
**Attachments:** 6567845.pdf

**Follow Up Flag:** Follow up  
**Due By:** Tuesday, November 23, 2021 7:00 AM  
**Flag Status:** Completed

External Email: Use caution before clicking links or opening attachments.

Good Morning,

The notice is scheduled to publish in the *Observer-Dispatch* on November 26. The total cost is \$98.88 and a proof is attached. An affidavit will be sent after publication.

Thank you!

Brittany Grady  
Public Notice Representative



Office: 844-254-5287

**From:** Ruberto, Laura <RubertL@bsk.com>  
**Sent:** Monday, November 22, 2021 8:40 AM  
**To:** Legal-Uticaod <legal@uticaod.com>  
**Subject:** 6567845 legal notice: Central Utica Building, LLC

Attached please find a legal notice to be published in the next available issue of the *Observer-Dispatch*.

Please provide a proof and confirm publication date by return email, and return the affidavit of publication and invoice to the undersigned. Thanks very much.

**Laura S. Ruberto**  
Paralegal  
Business  
315.738.1223 Direct  
315.724.2074 Fax  
[lruberto@bsk.com](mailto:lruberto@bsk.com)

501 Main Street, Utica, NY 13501-1245

This email is ONLY for the person(s) named in the message header. Unless otherwise indicated, it contains information that is confidential, privileged or exempt from disclosure under applicable law. If you have received it in error, please notify the sender of the error and delete the message.

IRS regulations require us to notify you that any tax advice contained in this communication (including any attachments) is not intended or written to be used, and cannot be used, for the purpose of avoiding penalties under the Internal Revenue Code. If you want a further description of this requirement, go to <https://www.bsk.com/disclaimer>.

**Order Confirmation**

Not an Invoice

Account Number:	638850
Customer Name:	Bond, Schoeneck & King, Pllc
Customer Address:	Bond, Schoeneck & King, Pllc 501 MAIN ST UTICA NY 13501
Contact Name:	Laura Ruberto
Contact Phone:	3157381223
Contact Email:	
PO Number:	

Date:	11/22/2021
Order Number:	6567845
Prepayment Amount:	\$ 0.00

Column Count:	2
Line Count:	82.0000
Height in Inches:	0.0000

Print

Product	#Insertions	Start - End	Category
UOD Observer-Dispatch	1	11/26/2021 - 11/26/2021	Public Notices
UOD uticaod.com	1	11/26/2021 - 11/26/2021	Public Notices

Total Order Confirmation

\$98.88



## Ad Preview

### NOTICE OF PUBLIC HEARING

NOTICE IS HEREBY GIVEN that a public hearing pursuant to Article 18-A of the New York State General Municipal Law, will be held by the Oneida County Industrial Development Agency (the "Agency") on Wednesday, November 22, 2021, at 10:00 a.m., in the Oneida County Board Room, Oneida County Board Office, Oneida County Office Building, 800 Park Avenue, Utica, New York in connection with the following matters:

1. The Agency will assist in the construction of an 80,000± square foot state-of-the-art medical office building and apartment facilities including parking areas and all infrastructure, utilities and amenities to support the same (collectively, the "Improvements") situated on parcels of land measuring 2.762± acres in the aggregate located at the corner of State and Central Streets at the intersection of the Oneida County Office Building and the Wynn Hospital in Utica, Oneida County, New York (the "Land"), and acquisition and installation of equipment in the Improvements (the "Equipment"), all for the purpose of providing a seamless and integrated health care delivery system together with the Wynn Hospital, and to enhance and expand the delivery of health care services to the community (the "Project"). The Improvements and the Equipment are intended to collectively support the construction and equipping of the Improvements is referred to as the "Project". The Facility will be initially operated and managed by the Company.

The Company will lease the Facility to the Agency, and the Agency will lease the Facility back to the Company pursuant to a lease agreement. The Agency will terminate the leasehold interest in the Facility. The Agency will sublease a 20,000± square foot portion of the Facility to Central New York Cardiology, P.C. (the "CNYC Sublessee") for its operation for the purpose of performing interventional cardiology services at the Wynn Hospital, to take cardiology call and provide cardiology services to patients admitted to the Wynn Hospital. The Agency will also sublease a portion of the Facility to Mohawk Valley ASC, LLC (the "MVASC Sublessee") for its operation for the purpose of operating an ambulatory surgery center with six operating rooms. The Company will sublease other portions of the Facility to MVHS and other medical practices whose physicians practice in, and need access to, the Wynn Hospital, and to other commercial and/or retail tenants, to provide ambulatory surgery services. Sublessees, together with the CNYC Sublessee and the MVASC Sublessees, are referred to collectively as the "Sublessees".

The Agency is contemplating providing financial assistance in the form of exemptions from mortgage recording taxes and exemptions from sales tax on materials and equipment acquired and installed in connection with the Project, such sales tax exemptions being valued at \$300,000. The Agency's request for assistance is a deviation from the Agency's Uniform Tax Exemption Policy, to be more particularly described in a Final Authorizing Resolution to be adopted by the Agency prior to the closing of the transactions described herein. Such financial assistance will be conditioned upon the Company creating, retaining and maintaining (or causing the Sublessees to create, retain and maintain) certain project

A representative of the Agency will at the above-stated time and place hear and accept written comments from all persons with views in favor of or opposed to either the proposed financial assistance to the Company or the location or nature of the Facility. Comments may also be submitted to the Agency in writing or electronically. The Agency will make the comments and the public hearing available to all members of the public and the benefits to be granted by the Agency during the Public Hearing by calling 1-888-418-9388 (Access code: 263 377 7943). Minutes of the Public Hearing will be transcribed and posted on the Agency's website. A copy of the Application for Financial Assistance filed by the Company with the Agency, including all attachments and exhibits, and a copy of the proposed Project, available for public inspection at the offices of the Agency, 584 Phoenix Drive, Rome, New York.

ONEIDA COUNTY INDUSTRIAL DEVELOPMENT AGENCY

Dated: November 22, 2021

By: /s/ Shawn M. Papale, Executive Director

16507845

**Ruberto, Laura**

---

**From:** Ruberto, Laura  
**Sent:** Tuesday, November 23, 2021 8:14 AM  
**To:** Anthony J. Picente; llapolla@uticaschools.org; mayor@cityofutica.com; bkaram@uticaschools.org  
**Cc:** realproperty@ocgov.net; Pilbeam, Kathy; Carvelli, Anthony; Padron, Daisy; Brian McClusky; William Morehouse; Haylee Lallier; Romano, Linda; Richard Maxwell; Merima Smajic; 'Billard, Mike'; Shawna Papale (spapale@mvedge.org); Mark Kaucher  
**Subject:** Notice of Public Hearing: Central Utica Building, LLC/Oneida County IDA  
**Attachments:** notice of public hearing (CUB)(13374231.2).pdf

Tracking:	Recipient	Delivery	Read
	Anthony J. Picente		
	llapolla@uticaschools.org		
	mayor@cityofutica.com		
	bkaram@uticaschools.org		
	realproperty@ocgov.net		
	Pilbeam, Kathy		
	Carvelli, Anthony		
	Padron, Daisy		
	Brian McClusky		
	William Morehouse		
	Haylee Lallier		
	Romano, Linda	Delivered: 11/23/2021 8:14 AM	Read: 11/23/2021 9:02 AM
	Richard Maxwell		
	Merima Smajic		
	'Billard, Mike'		
	Shawna Papale (spapale@mvedge.org)		
	Mark Kaucher		

On **December 10, 2021 at 10:00 a.m.**, local time, the Oneida County Industrial Development Agency (the "Agency") will conduct a public hearing regarding a project for **Central Utica Building, LLC**. Attached is a copy of the Notice of Public Hearing describing the project and the financial assistance contemplated by the Agency. The Notice has been submitted to the *Observer-Dispatch*, Utica, New York for publication.

You are welcome to attend such hearing and provide comments on the nature of the Facility and the provision of financial assistance. We are providing this notice to you, pursuant to Chapters 356 and 357 of the Laws of 1993, as the chief executive officer of an affected tax jurisdiction within which the project is located.

Should you desire to discuss this matter or if you have any questions concerning this notice please feel free to contact Shawna Papale at the Agency at telephone number 315-338-0393.

Be well,  
Laura

**Laura S. Ruberto**

Paralegal

Business

315.738.1223 Direct

315.724.2074 Fax

[lruberto@bsk.com](mailto:lruberto@bsk.com)



501 Main Street, Utica, NY 13501-1245

This email is ONLY for the person(s) named in the message header. Unless otherwise indicated, it contains information that is confidential, privileged or exempt from disclosure under applicable law. If you have received it in error, please notify the sender of the error and delete the message.

IRS regulations require us to notify you that any tax advice contained in this communication (including any attachments) is not intended or written to be used, and cannot be used, for the purpose of avoiding penalties under the Internal Revenue Code. If you want a further description of this requirement, go to <https://www.bsk.com/disclaimer>.

## NOTICE OF PUBLIC HEARING

NOTICE IS HEREBY GIVEN that a public hearing pursuant to Article 18-A of the New York State General Municipal Law, will be held by the Oneida County Industrial Development Agency (the "Agency") on the 10th day of December 2021 at 10:00 a.m., local time, at Oneida County Legislative Chambers, 10<sup>th</sup> Floor, Oneida County Office Building, 800 Park Avenue, Utica, New York in connection with the following matters:

Central Utica Building, LLC, on behalf of itself and/or the principals of Central Utica Building, LLC, and/or an entity formed or to be formed on behalf of any of the foregoing (collectively, the "Company") has applied to the Oneida County Industrial Development Agency (the "Agency") to enter into a transaction in which the Agency will assist in the construction of an 80,000± square foot state-of-the-art medical office building and appurtenant facilities including parking areas and all infrastructure, utilities and amenities to support the same (collectively, the "Improvements") situated on parcels of land measuring 2.90± acres in the aggregate adjacent to the new Wynn Hospital (the "Wynn Hospital") located at the Corner of State and Columbia Streets, City of Utica, Oneida County, New York (the "Land") and acquisition and installation of equipment in the Improvements (the "Equipment"), all for the purpose of providing a seamless and integrated health care delivery system together with the Wynn Hospital, and to enhance and expand the delivery of health care services to the community (the Land, the Improvements and the Equipment are referred to collectively as the "Facility" and the construction and equipping of the Improvements is referred to as the "Project"). The Facility will be initially operated and/or managed by the Company.

The Company will lease the Facility to the Agency, and the Agency will lease the Facility back to the Company pursuant to a leaseback agreement. At the end of the lease term, the Agency will terminate its leasehold interest in the Facility. The Company will sublease a 20,000± square foot portion of the Facility to Central New York Cardiology, P.C. (the "CNYC Sublessee") for its operation for the purpose of performing interventional cardiology services at the Wynn Hospital, to take cardiology call and provide cardiology services to patients admitted to the Wynn Hospital. The Company will sublease an 18,000± square foot portion of the Facility to Mohawk Valley ASC, LLC (the "MVASC Sublessee") for its operation for the purpose of operating an Article 28 licensed, Medicare certified multi-specialty ambulatory surgery center with six operating rooms. The Company will sublease other portions of the Facility to MVHS and other medical practices whose physicians practice in, and need access to, the Wynn Hospital, and to other commercial and/or retail tenants to provide complementary services (such sublessees, together with the CNYC Sublessee and the MVASC Sublessee, are referred to collectively as the "Sublessees").

The Agency is contemplating providing financial assistance in the form of exemptions from mortgage recording taxes and exemptions from sales tax on materials and equipment acquired and installed in connection with the Project, such sales tax exemptions to be limited to \$500,000.00, which financial assistance is a deviation from the Agency's Uniform Tax Exemption Policy, to be more particularly described in a Final

Authorizing Resolution to be adopted by the Agency prior to the closing of the transactions described herein. Such financial assistance will be conditioned upon the Company creating, retaining and maintaining (or causing the Sublessees to create, retain and maintain) certain employment at the Facility as a result of undertaking the Project.

A representative of the Agency will at the above-stated time and place hear and accept written comments from all persons with views in favor of or opposed to either the proposed financial assistance to the Company or the location or nature of the Facility. Comments may also be submitted to the Agency in writing or electronically prior to the Public Hearing. Members of the public may also access the Public Hearing and comment on the Project and the benefits to be granted to the Applicant by the Agency during the Public Hearing by calling 1-408-418-9388 (Access code: 263 377 79443). Minutes of the Public Hearing will be transcribed and posted on the Agency's website. A copy of the Application for Financial Assistance filed by the Company with the Agency, including an analysis of the costs and benefits of the proposed Project, is available for public inspection at the offices of the Agency, 584 Phoenix Drive, Rome, New York.

ONEIDA COUNTY INDUSTRIAL  
DEVELOPMENT AGENCY

Dated: November 22, 2021

By: /s/ Shawna M. Papale, Executive Director

From: Bruce A. Smith  
To: Steven Papale  
Cc: Ruberto Laura  
Subject: RE: Indemnification agreement  
Date: Monday, November 24, 2003 10:58:09 AM  
Attachments: IIA Final.doc

---

Here you go

Bruce A. Smith, Esq.  
Cohen Campaign Heckman Appel & Knoff, PLLC  
507 Main Street, Suite 310  
Syracuse, New York 13204  
Direct Phone: (315) 477-6291  
Direct Fax: (315) 425-3691  
E-mail: bsmith@ccklaw.com  
Website: <http://www.ccklaw.com>

<http://www.ccklaw.com>  
This electronic transmission contains information from the law firm of Cohen Campaign Heckman Appel & Knoff, PLLC, which is confidential, covered by the attorney-client privilege, and solely for the person or entity named above. If you are not the intended recipient, be aware that any disclosure, copying, distribution or use of this information is prohibited. If you have received this electronic mail transmission in error, please notify us by telephone, mail or electronic mail and destroy this communication.

-----Original Message-----  
From: Steven Papale <[spapale@msvedge.org](mailto:spapale@msvedge.org)>  
Sent: Monday, November 20, 2003 7:03 AM  
To: Bruce A. Smith <[basmith@ccklaw.com](mailto:basmith@ccklaw.com)>  
Cc: Ruberto, Laura <[laurer1@bck.com](mailto:laurer1@bck.com)>; Linda Romano <[Lromano1@bck.com](mailto:Lromano1@bck.com)>  
Subject: Indemnification agreement

Bruce did CUB sign the agreement and send it back to my attention? Please confirm. Thank you.

Steven Papale  
Sent from my iPhone  
CAUTION: This email originated from outside of the organization. Do not click links or open attachments unless you recognize the sender and know the content is safe.

## PRELIMINARY AGREEMENT

THIS PRELIMINARY AGREEMENT RELATING TO THE CENTRAL UTICA BUILDING, LLC PROJECT (the "Preliminary Agreement") is made this \_\_\_\_ day of November 2021 (the "Effective Date") by and among the Oneida County Industrial Development Agency (the "Agency"), Central Utica Building, LLC ("CUB"), a New York limited liability company, on behalf of itself and/or an entity formed or to be formed on behalf of CUB (collectively, the "Company"), and Mohawk Valley Health System ("MVHS").

### RECITALS

WHEREAS, the Company intends to submit an application (the "Application") to the Agency requesting that the Agency consider undertaking a project (the "Project") consisting of (1) construction of a 70,000 – 80,000 square foot medical office building (the "MOB") adjacent to, and within the footprint of, the new Wynn Hospital of the Mohawk Valley Health System (the "Wynn Hospital"); (2) provision of certain financial assistance in the form of exemptions from sales tax and exemptions from mortgage recording tax in connection with the Project (the "Financial Assistance"); (3) the acquisition of property located at 411 Columbia Street, City of Utica, Oneida County, New York (tax map number 318.041-2-38 (the "O'Brien Property"), which property is in the footprint of the Wynn Hospital and must be included in the MOB's property assemblage to accommodate the MOB's parking requirements, and (4) the sale or assignment of the Agency's interest in the O'Brien Property to the Company pursuant to a purchase and sale agreement between the Agency and the Company (the "Purchase Agreement"), all in furtherance of the development of the MOB and the Wynn Hospital; and

WHEREAS, the parties acknowledge that the involvement of the Agency in the Project is in part to acquire the O'Brien Property for purposes of providing parking for the MOB the CUB wishes to develop through eminent domain and to provide the Financial Assistance in furtherance of the Project; and

WHEREAS, by reason of undertaking the acquisition of the O'Brien Property the Agency may become responsible for certain liability obligations including without limitation all amounts expended by the Agency with respect to the acquisition of the O'Brien Property including, but not limited to: (1) advance payment; (2) all just compensation paid to condemnee; (3) all direct or indirect damages; (4) any interest thereon; (5) any additional allowance due to condemnee under EDPL §701 (the "Obligations"); and

WHEREAS, by this Preliminary Agreement MVHS and the Company wish to assure that as among them all Obligations are borne jointly and severally by MVHS and the Company and not by the Agency; and

WHEREAS, in the absence of such assurances the Agency is unwilling to undertake any Obligations with respect to the acquisition of the O'Brien Property.

NOW THEREFORE, in consideration of the mutual covenants expressed herein, and for other good and valuable consideration, receipt of which is hereby acknowledged, the parties agree as follows:

Section 1. (a) The Company and MVHS jointly and severally agree to forever defend, indemnify and hold the Agency, its members, officers, employees, and agents, and anyone for whose acts or omissions the Agency or any of them may be liable, harmless from and against all costs, losses,

expenses, claims, damages and liabilities of whatever kind or nature arising, directly or indirectly, out of or based on the acquisition and/or ownership of the O'Brien Property, the Agency's interest in the O'Brien Property, or all Obligations arising out of any contract or other arrangement therefor (and including any expenses incurred by the Agency in defending any claims, suits or actions which may arise as a result of any of the foregoing).

(b) The Company and MVHS jointly and severally agree to forever defend, indemnify and hold harmless the Agency, its members, officers, employees and agents, and anyone for whose acts or omissions the Agency or any of them may be liable, from and against all claims, causes of action, liabilities and expenses (including without limitation attorneys' fees) howsoever arising for loss or damage to property or any injury to or death of any person (including, without limitation, death or injury to any employee of the Company) that may occur subsequent to the date hereof by any cause whatsoever in relation to the acquisition of the O'Brien Property, and including, without limitation, any expenses incurred by the Agency in defending any claims, suits or actions which may arise as a result of the foregoing.

(c) The defense and indemnities provided for in this Section 1 shall apply whether or not the claim, liability, cause of action or expense is caused or alleged to be caused, in whole or in part, by the activities, acts, fault or negligence of the Agency, its members, officers, employees and agents, anyone under the direction and control of any of them, or anyone for whose acts or omissions the Agency or any of them may be liable, and whether or not based upon the breach of a statutory duty or obligation or any theory or rule of comparative or apportioned liability, subject only to any specific prohibition relating to the scope of indemnities imposed by law. Without limiting the generality of the foregoing, the foregoing indemnifications shall apply to and encompass any action (or alleged failure to act) of the Agency pursuant to the SEQR Act.

Section 2. The Company and MVHS jointly and severally agree that to reimburse the Agency for all reasonable and necessary direct out-of-pocket expenses that the Agency may incur as a consequence of executing this Preliminary Agreement or performing its Obligations, including but not limited to reasonable attorneys' fees that the Agency may incur in furtherance of the acquisition of the O'Brien Property.

Section 3. The Obligations of the Agency with respect to the acquisition of the O'Brien Property constitute a special obligation of the Agency, and all charges payable pursuant to or expenses or liabilities incurred thereunder shall be payable solely out of the revenues and other moneys of the Agency derived and to be derived from the acquisition of the O'Brien Property and any sale or other disposition of the O'Brien Property and the Company shall not look to any other assets of the Agency for satisfaction of the remedies of the Company. Neither the members, officers, agents or employees of the Agency, nor any person executing the Preliminary Agreement on behalf of the Agency, shall be liable personally or be subject to any personal liability or accountability by reason of the Obligations or the acquisition of the O'Brien Property. The Obligations of the Agency in connection with the acquisition of the O'Brien Property are not and shall not be an obligation of the State or any municipality of the State and neither the State nor any such municipality (including, without limitation, the County of Oneida), shall be liable thereon.

Section 4. The Company agrees to exhaust all reasonably available alternatives prior to the Agency's acquisition of the O'Brien Property.



Section 5. The Company and MVHS will take such further action and adopt such further proceedings as may be required to implement its aforesaid undertakings or as it may deem appropriate in pursuance thereof.

Section 6. This Preliminary Agreement shall take effect on the Effective Date and the indemnities and guarantee of indemnities contained herein shall survive notwithstanding the execution of future agreements relating to the Project, and notwithstanding whether the acquisition of the O'Brien Property closes for any reason whatsoever.

Section 7. This Preliminary Agreement may not be modified except by a writing signed by all parties hereto.

IN WITNESS WHEREOF, the parties hereto have entered into this Agreement as of the date first above written.

**ONEIDA COUNTY INDUSTRIAL  
DEVELOPMENT AGENCY**

By:

  
David C. Grow  
Chairman

**CENTRAL UTICA BUILDING, LLC**

By:

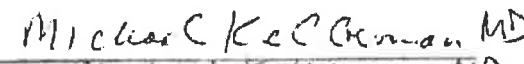
  
Name: Michael Kelberman MD  
Title:

**MOHAWK VALLEY HEALTH SYSTEM**

By:

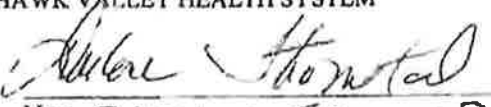
  
Name: DARLENE STROMSTAD  
Title: President/CEO

**From:** [Dave Quirello](#)  
**To:** "[Bruce A. Smith](#)"; "[Bernstein, Kevin](#)"; [pgoldman@goldmanpllc.com](#); "[Romano, Linda](#)"; "[Louis Aiello](#)"; "[Bob Scholefield](#)"  
**Cc:** [Shawna Papale](#)  
**Subject:** RE: OCIDA  
**Date:** Wednesday, December 1, 2021 5:51:23 PM  
**Attachments:** [image001.png](#)

---

Ok with new proposed times.

David Quirello, CMPE  
Chief Financial Officer



Central New York Cardiology  
2211 Genesee Street  
Utica NY 13501  
Phone: (315) 733-7598 ext. 2236  
Fax: (315) 733-7694  
[dquirello@cnycardiology.com](mailto:dquirello@cnycardiology.com)

**From:** Bruce A. Smith [<mailto:bsmith@ccblaw.com>]  
**Sent:** Wednesday, December 1, 2021 5:27 PM  
**To:** 'Bernstein, Kevin' <[bernstk@bsk.com](mailto:bernstk@bsk.com)>; [pgoldman@goldmanpllc.com](mailto:pgoldman@goldmanpllc.com); David Quirello ([dquirello@cnycardiology.com](mailto:dquirello@cnycardiology.com)) <[dquirello@cnycardiology.com](mailto:dquirello@cnycardiology.com)>; Romano, Linda <[romanol@bsk.com](mailto:romanol@bsk.com)>; 'Louis Aiello' <[laiello1@mvhealthsystem.org](mailto:laiello1@mvhealthsystem.org)>; 'Bob Scholefield' <[bscholef@mvhealthsystem.org](mailto:bscholef@mvhealthsystem.org)>  
**Cc:** 'Shawna Papale' <[spapale@mvedge.org](mailto:spapale@mvedge.org)>  
**Subject:** RE: OCIDA

I'm available at those times

Bruce A. Smith, Esq.  
Cohen Compagni Beckman Appler & Knoll, PLLC  
507 Plum Street, Suite 310  
Syracuse, New York 13204  
Direct Phone: (315) 477-6291  
Direct Fax: (315) 425-3691  
E-mail: [bsmith@ccblaw.com](mailto:bsmith@ccblaw.com)  
Website: [www.ccblaw.com](http://www.ccblaw.com)

**This electronic transmission contains information from the law firm of Cohen Compagni Beckman Appler & Knoll, PLLC, which is confidential, covered by the attorney-client privilege, and solely for the person or entity named above. If you are not the intended recipient, be aware that any disclosure, copying, distribution or use of this information is prohibited. If you have received this electronic mail transmission in error, please notify us by telephone, mail or electronic mail and destroy this communication.**

**From:** Bernstein, Kevin <[bernstk@bsk.com](mailto:bernstk@bsk.com)>  
**Sent:** Wednesday, December 1, 2021 5:24 PM  
**To:** Bruce A. Smith <[bsmith@ccblaw.com](mailto:bsmith@ccblaw.com)>; [pgoldman@goldmanpllc.com](mailto:pgoldman@goldmanpllc.com); David Quirello

([dquirello@cnycardiology.com](mailto:dquirello@cnycardiology.com)) <[dquirello@cnycardiology.com](mailto:dquirello@cnycardiology.com)>; Romano, Linda  
<[romanol@bsk.com](mailto:romanol@bsk.com)>; 'Louis Aiello' <[laiello1@myhealthsystem.org](mailto:laiello1@myhealthsystem.org)>; 'Bob Scholefield'  
<[bscholef@myhealthsystem.org](mailto:bscholef@myhealthsystem.org)>

Cc: 'Shawna Papale' <[spapale@mvedge.org](mailto:spapale@mvedge.org)>

Subject: RE: OCIDA

Can we do it at 3:30 or even better at 4?

**Kevin Bernstein**

Management Committee Chairman  
Environmental and Energy Practice Group  
315.218.8329 Direct  
315.218.8429 Fax  
315.727.5283 Cell  
[kbernstein@bsk.com](mailto:kbernstein@bsk.com)

One Lincoln Center, Syracuse, NY 13202-1355

This email is ONLY for the person(s) named in the message header. Unless otherwise indicated, it contains information that is confidential, privileged or exempt from disclosure under applicable law. If you have received it in error, please notify the sender of the error and delete the message.

For informed business counsel on COVID-19 issues, visit Bond's [COVID-19 Essential Resources for Business](#) page. To subscribe to our e-mails regarding COVID-19 or other topics, [click here](#).

From: Bruce A. Smith <[bsmith@ccbllaw.com](mailto:bsmith@ccbllaw.com)>

Sent: Wednesday, December 01, 2021 5:14 PM

To: [pgoldman@goldmanpllc.com](mailto:pgoldman@goldmanpllc.com); Bernstein, Kevin <[bernst@bsk.com](mailto:bernst@bsk.com)>; David Quirello  
([dquirello@cnycardiology.com](mailto:dquirello@cnycardiology.com)) <[dquirello@cnycardiology.com](mailto:dquirello@cnycardiology.com)>; Romano, Linda  
<[romanol@bsk.com](mailto:romanol@bsk.com)>; 'Louis Aiello' <[laiello1@myhealthsystem.org](mailto:laiello1@myhealthsystem.org)>; 'Bob Scholefield'  
<[bscholef@myhealthsystem.org](mailto:bscholef@myhealthsystem.org)>

Cc: 'Shawna Papale' <[spapale@mvedge.org](mailto:spapale@mvedge.org)>

Subject: OCIDA

**External Email: Use caution before clicking links or opening attachments.**

Shawna would like to set up a call tomorrow at 3 to discuss the project and the upcoming public hearing. Please let me know who's able to participate and I'll send out a Zoom invite.

Bruce A. Smith, Esq.  
Cohen Compagni Beckman Appler & Knoll, PLLC  
507 Plum Street, Suite 310  
Syracuse, New York 13204  
Direct Phone: (315) 477-6291  
Direct Fax: (315) 425-3691  
E-mail: [bsmith@ccbllaw.com](mailto:bsmith@ccbllaw.com)  
Website: [www.ccbllaw.com](http://www.ccbllaw.com)

This electronic transmission contains information from the law firm of Cohen Compagni Beckman Appler & Knoll, PLLC, which is confidential, covered by the attorney-client privilege, and solely for the person or entity named above. If you are not the intended recipient, be aware that any disclosure, copying, distribution

**or use of this information is prohibited. If you have received this electronic mail transmission in error, please notify us by telephone, mail or electronic mail and destroy this communication.**

**CAUTION: This email originated from outside of the organization. Do not click links or open attachments unless you recognize the sender and know the content is safe.**



**From:** [Dave Quirello](#)  
**To:** [Shawna Papale](#); [Steven J. Dimeo](#)  
**Cc:** ["Bruce A. Smith"](#); [michaelkelberman@roadrunner.com](mailto:michaelkelberman@roadrunner.com)  
**Subject:** Public Hearing  
**Date:** Friday, December 10, 2021 11:11:18 AM  
**Attachments:** [image002.png](#)

---

Good morning Shawna and Steve,

I joined the public hearing via Web Ex. When I went speak no one could hear. I wanted to comment on the cost benefit analysis. "Previous speakers spoke to the benefit of both the enhanced integrated health services and positive financial impact on the community. But more specifically factoring the retained and created jobs, the multipliers or both the indirect jobs and construction jobs this project provides just under \$100MM in earnings in the first three years alone. Those earnings generate \$4,000,000 in revenues from income. It just doesn't stop there as these individuals will buy new cars, gas, stay in hotels, eat in restaurants and purchase other taxable goods and services. Sales tax generated by this is estimated at almost \$3,500,000. Additionally, the same individuals will buy or build homes generating another \$700,000 plus in revenues related to property taxes. A total of between \$8-8.5MM in benefit to the community."

Please let me know if you have any questions.

David Quirello, CMPE  
Chief Financial Officer



**Central New York Cardiology**

2211 Genesee Street  
Utica NY 13501  
Phone: (315) 733-7598 ext. 2236  
Fax: (315) 733-7694  
[dquirello@cnycardiology.com](mailto:dquirello@cnycardiology.com)

**CAUTION:** This email originated from outside of the organization. Do not click links or open attachments unless you recognize the sender and know the content is safe.

**From:** [Bruce A. Smith](#)  
**To:** [Shawna Papale](#)  
**Subject:** RE: letter  
**Date:** Friday, December 10, 2021 3:22:50 PM  
**Attachments:** [Dec 10letter to OCIDA.pdf](#)

---

OK?

Bruce A. Smith, Esq.  
Cohen Compagni Beckman Appler & Knoll, PLLC  
507 Plum Street, Suite 310  
Syracuse, New York 13204  
Direct Phone: (315) 477-6291  
Direct Fax: (315) 425-3691  
E-mail: [bsmith@ccblaw.com](mailto:bsmith@ccblaw.com)  
Website: [www.ccblaw.com](http://www.ccblaw.com)

**This electronic transmission contains information from the law firm of Cohen Compagni Beckman Appler & Knoll, PLLC, which is confidential, covered by the attorney-client privilege, and solely for the person or entity named above. If you are not the intended recipient, be aware that any disclosure, copying, distribution or use of this information is prohibited. If you have received this electronic mail transmission in error, please notify us by telephone, mail or electronic mail and destroy this communication.**

**From:** Shawna Papale <[spapale@mvedge.org](mailto:spapale@mvedge.org)>  
**Sent:** Friday, December 10, 2021 2:55 PM  
**To:** Bruce A. Smith <[bsmith@ccblaw.com](mailto:bsmith@ccblaw.com)>  
**Subject:** letter

Bruce I am confirming per our conversation you will be sending a letter? We are working up against a deadline to get the IDA mailing out. Thank you.

Shawna Papale  
Chief Administrative Officer  
Mohawk Valley EDGE  
584 Phoenix Drive  
Rome, NY 13441  
315-338-0393

**CAUTION:** This email originated from outside of the organization. Do not click links or open attachments unless you recognize the sender and know the content is safe.



**Bruce A Smith**  
Direct: 315.477.6291  
Direct Fax: 315.425.3691  
Email: bsmith@ccblaw.com

December 10, 2021

BY E-MAIL

Shawna M. Papale, Executive Director  
Oneida County Industrial Development Agency  
584 Phoenix Drive  
Rome, New York 13441

Re: Central Utica Building Project

Dear Ms. Papale:

Central Utica Building, LLC ("CUB") respectfully requests that OCIDA reconsider its limitation, set forth in its inducement resolution, on the sales tax exemption to be provided to the project. CUB requests that the sales tax exemption not be limited to \$500,000 and that it apply to all costs associated with the construction and equipping of the project, the value of which exemption was estimated to be \$1,820,000 in our application.

In addition, CUB respectfully requests the opportunity to make a presentation at OCIDA's December 17 meeting.

Thank you for your consideration.

Very truly yours,

*Bruce A. Smith*

Bruce A. Smith



Anthony J. Picente Jr.  
County Executive

Shawna M. Papale  
Secretary/ Treasurer/  
Executive Director

Jennifer Waters  
Assistant Secretary

ONEIDA COUNTY INDUSTRIAL  
DEVELOPMENT AGENCY

**OCIDA**



584 Phoenix Drive  
Rome, New York 13441-4105  
(315) 338-0393, fax (315) 338-5694

David C. Grow  
Chairman

Michael Fitzgerald  
Vice Chairman

Ferris Betrus Jr.  
Kirk Hinman

Mary Faith Messenger

Eugene Quadraro  
Stephen Zogby

To: Oneida County Industrial Development Agency Board of Directors  
From: Shawna M. Papale  
Date: December 10, 2021  
RE: OCIDA Meeting Agenda

The Oneida County Industrial Development Agency shall meet – 8:00 AM Friday, December 17, 2021.

Members of the public may listen to the Agency meeting by calling +1-408-418-9388, Access code: 263 032 56661 or attend in person. The Minutes of the Agency meeting will transcribed and posted on the OCIDA website.

1. Executive Session at 8:00 AM if needed
2. Approve minutes – November 19, 2021 and December 1, 2021
3. Financial Review
  - a) Interim Financials
4. Review and consideration of **annual Housekeeping Resolution**. Annual Housekeeping Resolution (1) documents election of officers and committee members; (2) confirms the occurrence of the annual meeting and actions taken at that meeting; (3) provides for the selection of staff and contracted services; (4) affirms policies and procedures of the agency/corporation and (5) officially adopts the meeting schedule for 2022.
5. Consider a final authorizing resolution relating to the **GSPP Hillsboro & Dunbar, LLC** (Camden Community Solar Project) Facility, approving financial assistance in the form of reduction of real property taxes for a period of 25 years (value estimated at \$1,729,030), consistent with the Agency's Uniform Tax Exemption Policy (Community Solar Policy) and authorizing the form and execution of related documents, subject to counsel review. The Agency conducted a public hearing on December 9, 2021.
6. Consider a request from **Central Utica Building, LLC Facility** to amend an inducement resolution to provide for financial assistance in the form of exemptions from sales tax (estimated at \$1,820,000 not to exceed \$2,002,000) and exemptions from mortgage recording tax (estimated at

Anthony J. Picente Jr.  
County Executive

Shawna M. Papale  
Secretary/ Treasurer/  
Executive Director

Jennifer Waters  
Assistant Secretary

ONEIDA COUNTY INDUSTRIAL  
DEVELOPMENT AGENCY

**OCIDA**



584 Phoenix Drive  
Rome, New York 13441-4105  
(315)338-0393, fax (315)338-5694

David C. Grow  
Chairman  
Michael Fitzgerald  
Vice Chairman

Ferris Betrus Jr.  
Kirk Hinman  
Mary Falth Messenger  
Eugene Quadraro  
Stephen Zogby

\$128,138 not to exceed \$140,951), which financial assistance is consistent with the Agency's Uniform Tax Exemption Policy, and authorizing the Agency to conduct a public hearing. The Agency adopted an inducement resolution on November 19, 2021 limiting sales tax exemption to \$500,000 and conducted a public hearing on December 10, 2021 with respect to said proposed financial assistance.

7. Consider an inducement resolution relating to the **SG Onedia PV, LLC** (Trenton Community Solar) Facility, providing preliminary approval for financial assistance consisting of reduction of real property taxes for a period of twenty-five years (value estimated at \$791,069.00), which financial assistance is consistent with the Agency's Uniform Tax Exemption Policy (Community Solar Policy) and authorizing the Agency to conduct a public hearing.
8. Consider a SEQR resolution relating to the **SG Onedia PV, LLC** (Trenton Community Solar) Facility. The Town of Trenton Planning Board acted as lead agency for the SEQR review and on March 9, 2021 determined the action was an "Unlisted Action."
9. Old Business

Next meeting date – **Friday, January 21, 2022** at 8 AM at 584 Phoenix Drive, Rome, NY

Anthony J. Picente Jr.  
County Executive

Shawna M. Papale  
Secretary/Executive Director

Jennifer Waters  
Assistant Secretary

ONEIDA COUNTY INDUSTRIAL  
DEVELOPMENT AGENCY



584 Phoenix Drive,  
Rome, New York 13441-4105  
(315) 338-0393, fax (315) 338-5694  
[info@nvedge.org](mailto:info@nvedge.org) [www.nvedge.org](http://www.nvedge.org)

David C. Grow  
Chairman

Michael Fitzgerald  
Vice Chairperson

Mary Faith Messenger  
Treasurer

Ferris Betrus, Jr.  
Kirk Hinman  
Eugene Quadraro  
Stephen Zogby

TO: OCIDA Board of Directors  
FROM: Mark Kaucher  
DATE: December 11, 2021

RE: Central Utica Building, LLC Public Hearing, Dec. 10, 2021 Public Hearing Minutes  
WebEx teleconference and at Oneida County Legislative Chambers, 10<sup>th</sup> Floor, Oneida County  
Office Building, 800 Park Avenue, Utica.

**Attendance:** Gerald Fiorini, Chair Oneida County Board of Legislators(OCBOL); Evon Ervin (OCBOL);  
Tim Julian (OCBOL); Mike Billard (OCBOL); Maya Miller(OCBOL); Anthony Picente, Oneida County  
Executive, Dr. Michael Kelberman, CNY Cardiology; Bruce Smith, CCB Law; Robert Scholefield, MVHS;  
Lou Aiello, MVHS; David Quirillo, CNY Cardiology (Webex); Michael Fogel, Brown, Duke & Fogel  
(Webex teleconference); Patrick Donnelly, unidentified teleconference call in user.

**Representing the Agency:** Shawna Papale, Jennifer Waters, Mark Kaucher, Tim Fitzgerald

Jennifer Waters opened the public hearing opened at 10:00 AM.

Consensus of the attendees was to waive public recitation the public hearing notice. She noted that  
MVHS has also provided a PowerPoint presentation that will be entered into the record.

Ms. Waters invited the first speaker to the podium.

**Speaker #1, Robert Scholefield:**

Mr. Scholefield thanked the Agency for allowing him the opportunity to speak, and introduced  
himself as Executive Vice-President with Mohawk Valley Health System (MVHS), and explained that  
he is overseeing construction of the new Wynn Hospital (WH). He first noted years ago, before there  
was any construction beginning, the administrative staff and Board of Trustees of MVHS had to  
create vision statement: what is it that they were they looking to accomplish as a result of building  
this state of the art facility in downtown Utica. He read the statement: To create an advanced health  
care campus for MVHS through design that promotes the health of patients, optimizes the work  
environment for our care givers and serves as a catalyst for revitalization of downtown Utica. He  
believes this will be accomplished with this project. MVHS is making a \$611 million investment in  
this 672, 000 square foot building in downtown Utica. This will be a comprehensive clinical campus

that's designed for accessibilities of their providers and their patients. It is intended to be an inpatient and outpatient campus. The WH will be the inpatient facility and medical office building (MOB) associated with the WH will be the outpatient facility, with the WH being the flagship building on that campus. The MOB and ambulatory surgery center (ASC) is in adjacent proximity to the WH which is a crucial component of the clinical campus because it will provide services that will not be provided within the WH itself. The ASC is necessary to accomplish the planned outpatient services. A loss of this cohesive partnership would have a significant negative impact on the social good of this community as the comprehensive campus for all of the customers, patients, providers and staff would be lost. The MOB and the ASC is included in the clinical campus and is referenced in the certificate of need application which was approved by the State of New York in 2019. It was also included in the Downtown Revitalization Grant Application, which resulted in the \$300 million grant that was awarded to MVHS to build the WH. The MOB was also a part of the SEQR findings and environmental impact statement prepared by O'Brien and Gere, now referred to as Rambol, and this can be found in the March 19<sup>th</sup> statement on Page 8. It was always intended that this building (MOB) be developed by a third party. MVHS never intended to build the MOB building on its own and it was not part of the financing for the project, nor is it part of the grant from the state of New York. Right from the beginning they worked with local physicians to make this building a desirable location for those who are hospital-based physicians who themselves will utilize both locations to take care of their patients and the outpatients will have close proximity to the hospital itself. They were required by the New York State Department of Health, as part of their grant application, to put together a number of quality metrics, to be able to ascertain for them, what types of benefits the \$300 million grant in the downtown will bring to health care in this community. They created what they call their "Ten Aims" which are actual measurable indicators that MVHS will measure for five years after the campus project is completed to ensure that the care given within this facility improves significantly over the care that they are able to deliver today. Included in those Aims are specific items such as reduction of the amount of traffic, sound, noise and throughput within the WH/ inpatient facility, which will be accomplished by removing a lot of the outpatient services from the WH and locating them into the MOB that will be immediately adjacent to the WH but on the clinical campus. He noted on the site plan dated March 19, 2019 and submitted to the City of Utica Planning Board, the MOB at that location across from the Wynn Campus on Columbia Street was identified as a future location of a MOB, and made it clear at that meeting that it would be a third party development, but that MVHS would utilize numerous services within inside that building.

**Speaker #2, Lou Aiello:**

Mr. Aiello identified himself as the Chief Financial Officer for MVHS and talked about the future state of the campus and the MOB and the ASC that would be developed by CUB. The CUB is a group of local physicians who have stepped up to develop the MOB, which MVHS appreciates, as MVHS is focused on the financing and capital needs of the WH itself. The MOB will provide space for those physicians, particularly those that support the major product lines of the MVHS; which are identified community needs of advanced endoscopy, stroke, neurovascular, surgery and cardiac services. Those physicians also provide that advanced care and complementing services in the WH. In planning for the WH many other communities and facilities were visited to ensure that a successful

campus with programming and services was planned and developed. When planning took place years ago, MVHS and its partners did site visits around the country and repetitively saw these MOBs and ASCs as part of the campuses and how successful they are, not only in complementing the care they deliver, but in the economic development of the region. Having office space adjacent to and on the campus is an integral part of the plan. The ASC itself is part of that transformation process as MHVS applied for the Certificate of Need and grant from the State of New York, to not just take the care deliver today and move it to a shiny new building, but to transform that care based upon those 10 Aims that Mr. Scholefield represented earlier. The ASC is an integral part of the plan to transform care from an inpatient setting to a more appropriate and more cost appropriate setting in the outpatient setting. In addition to the ASC, the building will also provide diagnostic services and radiology services, ultrasound, PET scan, general radiology and some lab services in a patient service center, to compliment what is going on the overall campus. An effort is to not flood the hospital with patients who don't need to be in the WH for services, but in a convenient location adjacent to it – the MOB. The ASC itself will be built with six operating rooms and the WH will have 14 operating rooms. Currently there are 22 operating rooms between the two hospital campuses as inpatient facilities. When building the new WH for the future they looked at the data and the types of cases that were being done in the hospital setting that could be done in an outpatient setting. This was how they determined the need for 14 operating rooms for the new WH, thus recognizing the ASC would handle six operating rooms, complementing the 14 in a more appropriate setting. The ASC is expected to have over 5,000 cases done annually to start. Those are cases that are now being done in the two acute care hospital campuses. The project helps the community by being in close proximity to the WH so that cohesive integrative care can be delivered on the campus. Patients know where to go for their care. Know where to go for their diagnostic care. For their outpatient treatment. Then, obviously, to the WH for their inpatient and emergency treatment. MVHS didn't just stumble across the main focus on cardiac care; the statistics show a concerning prevalence in our area which commands significant care in this area. MVHS is now the only hospital in NYS to be a cardiac hospital with their newly earned distinction. They expect growth of cardiac disease in our region to be 11% between 2022 and 2025. The other financial benefit to the community, as they shift the 5,000 surgery cases over from the hospital to the ASC, is a significant cost benefit to the patient and to the payors. This is due to a difference in reimbursement. The difference in reimbursement is because it is more cost efficient to deliver care at a lower cost in the ACS. Surgery in the hospital costs the hospital, the patient and the payor more. With this transformation in care, there will be a significant reduction in costs. Part of the plan and reason they are able to do this now is because of this transformation with the new campus as they build the new efficient hospital and system thus affording the loss of cases to the ASC because they now have a cohesive, complimentary service for our community with the MOB. He stressed that the MOB/ASC by CUB will be a property tax paying entity. A significant amount of property tax revenue will be generated. There is no payment in lieu of tax agreement being requested. In his opinion, it could end up being one of the highest assessments in the City. He explained why the requested IDA financial assistance was needed: As everyone knows, whether you are undertaking a project at one's home or ones business, material costs have increased significantly. The pandemic has had a major impact on this. In addition to the increased cost of materials, the delays in construction time have also lead to

increased costs. This applies to projects of all sizes. Without the financial assistance that is being requested, there are certain areas of the building that may not be built out or delayed, and it could affect recruitment of providers. The assistance is really needed because of the increase in costs not anticipated five years earlier when the facility was being considered and how it is going to be paid for it long term. In conclusion, he thanked the Agency.

**Speaker #3, Dr. Michael Kelberman:**

Dr. Kelberman thanked the Agency for allowing him the opportunity and introduced himself as a Senior Partner with CNY Cardiology and Director of Cardiology at MVHS. It stated that he would like to take a 10,000 foot view of health care in general and why this project is so important. Healthcare is a rapidly changing, hotly competitive environment. There are a lot of things changing and they are in competition for physicians, staff, equipment, and all of these things have escalated to heights hereto really not seen. This is an opportunity in our community to create a health system and improve a health system that would be productive going forward. Some of this requires us to change. This is synergism. This is partnerships. The health system has reached out to CNY Cardiology and asked us to partner to create the state of the art health system we need. Some examples of this are: the promise of a new hospital, the promise of an ASC and offices that are conveniently and helpfully located has already enabled them to bring on three new doctors this year. They are top doctors from the absolute best programs in the country. They are top of the line and he can supply that information to anyone interested. They are replacing retiring and older physicians and thus gearing them up for the growth anticipate in cardiac care. An important concept to consider is that the health system provides obvious care to Oneida County, but to surround counties, probably around 200,000 people or so, where they have tremendous opportunity to experience flow. Internally at CNY Cardiology, with some of the things they're doing, they expect 20 to 30% growth over the next three to five years. If you have a \$1 billion health system and everybody replicates what they're doing, which admittedly, is a very high tech competitive field, but if you have a \$1 billion health system that grows 20 to 30%, that's \$200 to \$300 million additional revenue. He noted these are high tech jobs. Its internal growth for something that is extremely important to an area and is as high-tech and productive as any entity you could attract. So with this new synergism, this competitive new health care environment, they are positioned really well. The American College of Cardiology, the doctors that practice cardiology in this country and lead the way, have created a certification system that's rigorous. They spent two years undergoing scrutiny and they are now the first health system to receive the designation of a heart center by the American College of Cardiology. There will be others eventually, but the fact that they were able to do that and being able to create an impression to a very critical group of people in an organization, speaks to their capability to do this. In terms of technology and equipment, he said cardiology and high tech medicine is moving very quickly. There is new diagnostic equipment they plan to acquire; Cardiac PET scanning is now the new frontier in diagnosing heart disease. This is crucial because the diagnosis has improved. The ability to predict how a patient will do is improved and the ability to decide what they need is improved. They are big and expensive and they currently have no room for it either. They hope to bring this new \$10 million piece of equipment into the new MOB. As for

procedures, heart valves can now be fixed without surgery, but requires highly-specialized people, and it is extremely competitive to get them. With the new hospital with a synergistic ASC working together, they will get them. They are attracting the best and the brightest and the three doctors they have gotten this year speaks to this capability. Its already having an impact. The people want to see what's there. When you show them the plans and you show them the building, that's what really impacts them to decide to come. They see this as an absolute win-win for the community. It's a very, very expensive proposition for them with an investment north of \$40 million. A lot of people involved who had to be convinced this is where the future is and they have done that. Everybody is all in and anything that can be done to help them create this absolute state of the art MOB and ASC would be greatly appreciated. He thanked the Agency.

**Speaker #4, Anthony Picente:**

County Executive Anthony Picente thanked the Agency for the opportunity to speak. He stated that the MVHS project, in total, has been a great focus for the County of Oneida, and certainly the City of Utica, and the entire region. The proposal before the Agency for the MOB along with the ASC has been a key piece from the very beginning of this process and was a key part of securing the state aid, while as Mr. Scholefield said, it is not a part of the WH, the project itself, and the entire campus footprint, had always included the MOB and the ASC , and possibly more in the future, but this one was in the first piece of it. The funding for the MOB however is not in the dollars secured from NYS but is part of the campus project itself including the surgical center as being part of the MOB, and possibly more in the future. As we look at what is taking place around, certainly the pandemic and our health care needs in this community, you are seeing these types of centers popping up around hospitals, and as Dr. Kelberman, Mr. Aiello, and Mr. Scholefield explained, and surely other professionals would do the same. They explained why it is so important to have the MOB as part of the campus and so close to the hospital. As the professionals and the medical systems will tell you, and as NYS Health and other health departments will point to, in terms of medical offices and hospital systems, the importance of having an ASC in close proximity so that the overall capacity numbers, costs, structure, and flow, can be better managed. County Executive noted he has been very involved in the hospital project as this county government has in regards to the parking facility, but in looking at the total structure of this system and what had been anticipated and what had always been there from the beginning, he supports the need for the MOB. He referenced Mr. Aiello's earlier statement regarding real property taxes, and he thinks it's important to know this group is not requesting a PILOT, and that it will be paying property taxes. He noted that the taxes paid by the MOB will probably be equal to, or as close, to what were in the parcels that were in the campus footprint before the demolition and before the construction of the hospital system. He is very supportive of this project and as he spoke to the IDA previously, he encourages them to take up this application favorably. He thanked the Agency.

Ms. Waters asked if there were any others who wished to make a public comment. On the recording Call-in user, Michael Fogel stated that he tried to answer earlier on, but his attempts were not audible at the public hearing. Ms. Waters stated that if anyone was experiencing technical

difficulties and wishes to make a statement, written comments will be accepted as outlined in the public hearing notice.

There being no further request to make statements, Ms. Waters closed the public hearing at 10:24 AM.

Subsequent to the Public Hearing, the Agency received both an e-mail and a letter from individuals who were unable to make audible contact at the public hearing, but who wished to make public statements. An email/ letter from Patrick Donnelly/ Michael Fogel, Brown Duke & Fogel, is attached to this memo and the text from the email from David Quirillo, CNY Cardiology, can be found below:

**December 10, 2021 e-mail From David Quirillo, CMPE, Chief Financial Officer, CNY Cardiology:**

"I joined the public hearing via Web Ex. When I went speak no one could hear. I wanted to comment on the cost benefit analysis. "Previous speakers spoke to the benefit of both the enhanced integrated health services and positive financial impact on the community. But more specifically factoring the retained and created jobs, the multipliers or both the indirect jobs and construction jobs this project provides just under \$100MM in earnings in the first three years alone. Those earnings generate \$4,000,000 in revenues from income. It just doesn't stop there as these individuals will buy new cars, gas, stay in hotels, eat-in restaurants and purchase other taxable goods and services. Sales tax generated by this is estimated at almost \$3,500,000. Additionally, the same individuals will buy or build homes generating another \$700,000 plus in revenues related to property taxes. A total of between \$8-8.5MM in benefit to the community." Please let me know if you have any questions."

Respectfully submitted,

Mark Kaucher

Attached: Brown Duke & Fogel, P.C. December 10, 2021 Letter  
MVHS PowerPoint Presentation



# BROWN DUKE & FOGEL, P.C.

ATTORNEYS AND COUNSELORS AT LAW

WWW.BDFLEGAL.COM

Michael A. Fogel, Esq.  
Brown Duke & Fogel, P.C.  
120 Madison Street, Suite 1620  
Syracuse, New York 13202  
[mfogel@bdflegal.com](mailto:mfogel@bdflegal.com)  
Tel: 315-399-4343

December 10, 2021

Executive Director Shawna Papale  
Oneida County Industrial Development Agency  
584 Phoenix Drive  
Rome, New York 13441-4105  
[info@mvedge.org](mailto:info@mvedge.org)  
[spapale@mvedge.org](mailto:spapale@mvedge.org)

**Re: Central Utica Building, LLC Application for Financial Assistance  
Public Hearing on December 10, 2021 at 10 a.m.**

Dear Executive Director Papale and Oneida County Industrial Development Agency:

This office represents Bowers Development, LLC ("Bowers Development").

Please accept this letter as Bowers Development's comments on the Central Utica Building, LLC Application for Financial Assistance (the "Application") to the Oneida County Industrial Development Agency ("OCIDA"). Pursuant to the instructions contained in the Notice of Hearing, we dialed in to the call-in number provided promptly at 10 a.m. Unfortunately, when I attempted to identify myself you could not hear me. I even attempted to dial in from a different phone and announced myself but was still unable to be heard. It appears it was a technical problem on your end. My office was able to reach Executive Director Shawna Papale by phone after the hearing, and Executive Director Papale directed my office to submit our comments by email today and stated that our comments will be included with the public hearing transcript.

Bowers Development is one of the most active developers in the City of Utica. Bowers Development is the contract-vendee of the property located at 411 Columbia Street (Tax Map 218.-41-2-38) (the "O'Brien Parcel") and will be constructing a brand-new medical office building ("MOB") on the O'Brien Parcel. Both Central Utica Building, LLC and Mohawk Valley Health System are fully aware of Bowers Development's contract-vendee status and intent to construct its own MOB on the O'Brien Parcel. Yet, without Bowers Development's consent or permission, the O'Brien Parcel has been included in the Application as part of the Central Utica Building, LLC MOB project. In fact, the Application acknowledges that Central Utica Building, LLC does not own or control the O'Brien Parcel, but yet admits that "[w]ithout this property it will be impractical if not impossible to construct the MOB as proposed." It is disturbing and shocking that Central Utica Building, LLC would submit an Application for a project which includes property that it admits that it does not even own or control and which by its own admission it needs to construct the project. This should not be tolerated by OCIDA.

Therefore, we submit that OCIDA should not, and in fact, cannot as a matter of law, proceed to process, let alone approve, the Application because Central Utica Building does not even own all of the property which is part of the Application.

Furthermore, it would be improper for OCIDA to proceed to condemn the O'Brien Parcel by eminent domain, as requested by Central Utica Building, LLC. As a threshold matter, OCIDA should not be taking property from one private property owner and developer who intends to develop an MOB and give it to another developer to develop an MOB. This is not consistent with the purpose and authority of OCIDA, and we believe it would also be in violation of Eminent Domain Procedure Law.

Nonetheless, if OCIDA does proceed with eminent domain, Bowers Development fully intends to oppose the taking and will pursue any-and-all legal remedies available to it to prevent such taking, and to seek just compensation, if such taking does occur. In addition, any taking of the O'Brien Parcel will result in significant direct, indirect and consequential financial damages to Bowers Development for which it fully intends to seek compensation for from all responsible parties.

Further, based on the Application that has been made available to the public, the Application appears to be incomplete. It appears to be missing the required completed SEQRA forms, and a completed Cost Benefit Analysis. Therefore, these documents need to be completed by the Applicant, and provided to the public for comment before OCIDA moves forward with processing and potentially approving the Application.

Thank you for your attention to this matter. Please include this letter in the record of your consideration of the Application.

Very truly yours,

BROWN DUKE & FOGEL, P.C.

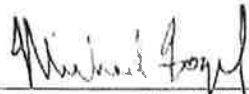
By:   
Michael A. Fogel, Esq.

# THE WYNN HOSPITAL

Medical Office Building/  
MVHS Ambulatory Surgery  
Center

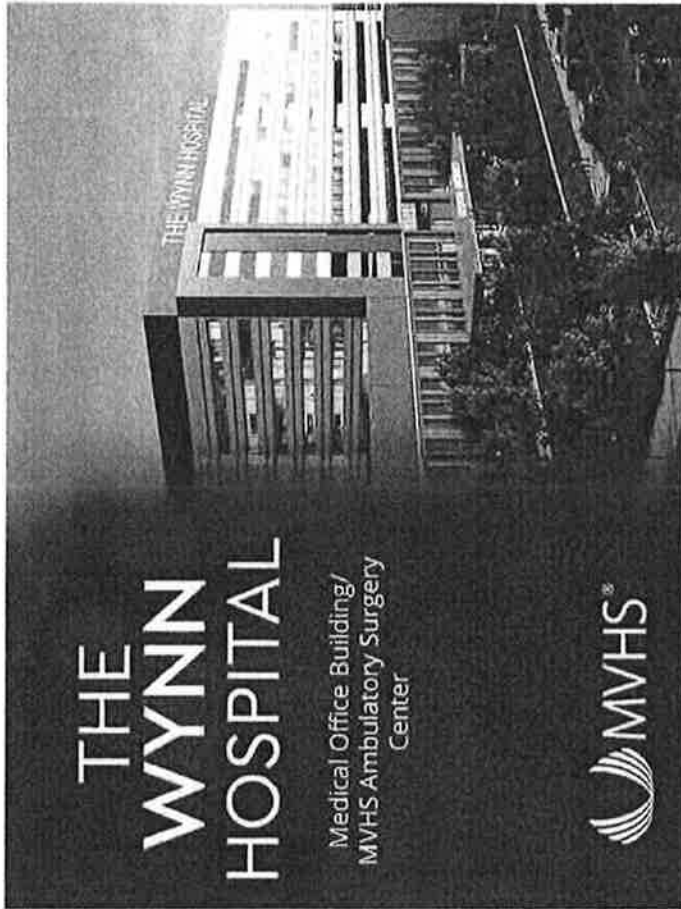

## Vision Statement

To create an advanced healthcare campus for MVHS through design that promotes the health of patients, optimizes the work environment for caregivers and serves as a catalyst for the revitalization of downtown Utica.

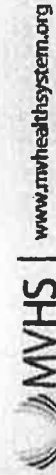

12/14/2021

## Medical Office Building (MOB)/ Ambulatory Surgery Center (ASC)

- VHS is making a \$611 million investment in The Wynn Hospital Clinical Campus – a comprehensive medical campus designed for accessibility for providers and patients, both in and outpatient services as well as the ability to develop a robust teaching program. The Wynn Hospital is the flagship piece of the campus.
- The MOB/ASU and its adjacent proximity to The Wynn Hospital is a crucial piece of the project because the services housed in this building complement the work being done in the hospital and work collaboratively to support each other. The loss of this cohesive partnership would have a significantly negative impact on the social good of the community as the cohesive campus for all customers, patients, providers and staff, would be lost.

## Medical Office Building (MOB)/ Ambulatory Surgery Center (ASC)

- The MOB/ASU was included in MVHS's new clinical campus plans from the early planning stages.
  - It was included in the NYS Certificate of Need, the Downtown Revitalization Grant application which resulted in a \$300 million award, and in the SEQRA Final Environmental Impact Statement Prepared by O'Brien & Gere Engineers (Ramboll) March 2019 (page 8).
- This building was always intended to be developed by a third party with MVHS as a tenant. MVHS worked with local hospital-based physician groups to determine a desire to develop this building.

# Ten Aims – Guiding Principles

<p>1  <b>1</b></p> <p>Attraction of patients to the hospital</p>	<p>2  <b>2</b></p> <p>Accessibility and convenience of the hospital</p>	<p>3  <b>3</b></p> <p>Communication and patient participation</p>	<p>4  <b>4</b></p> <p>Minimizing patient waiting times</p>	<p>5  <b>5</b></p> <p>Improved patient safety</p>	<p>6  <b>6</b></p> <p>Efficient use of resources</p>
<p>7  <b>7</b></p> <p>Improved patient safety and reduction of hospital acquired infection rates</p>	<p>8  <b>8</b></p> <p>Adherence to infection control practices</p>	<p>9  <b>9</b></p> <p>Education to minimize hospital acquired infections</p>	<p>10  <b>10</b></p> <p>Minimizing patient waiting times</p>		

MVHS | [www.mvrhealthsystem.org](http://www.mvrhealthsystem.org)

12/14/2021

# Site Plan

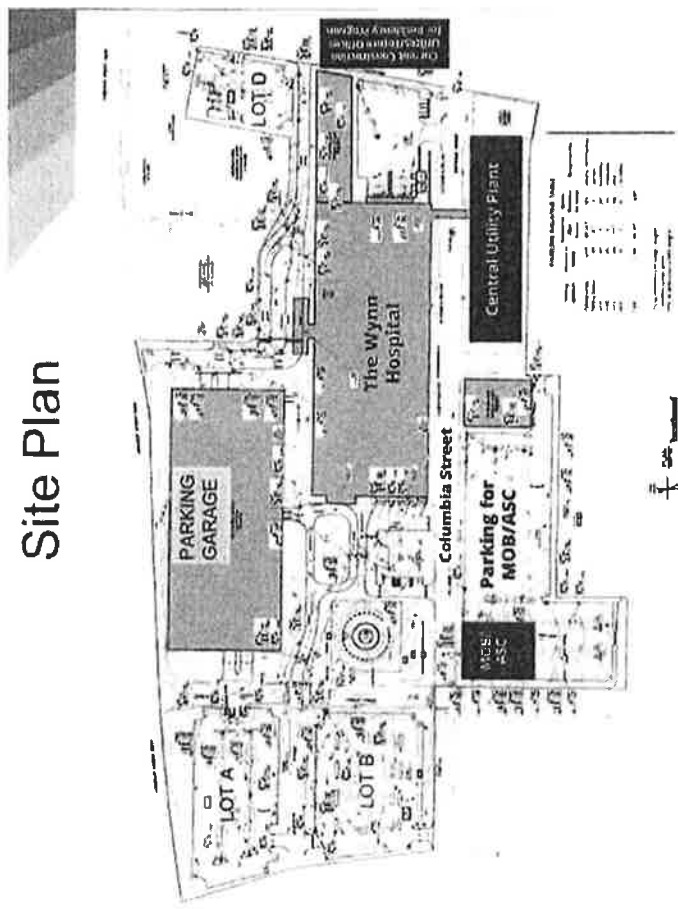

## What will services will be housed in the MOB/ASC?

- Centralica Building (CUB), a group of local physicians, has stepped up to develop the building and will rent out physician practices as well as MVHS who will lease a significant amount of space. We are grateful to the CUB group for taking on this project.
- The MOB will provide office space to physician practices, particularly those that support major product lines of MVHS, based on community need: Endoscopy, Stroke and Neurovascular, Surgery, Cardiac, etc.
- The ASU is a new service for MVHS and will provide a space for same-day surgical care, including diagnostic and preventive procedures. ASCs have transformed the outpatient experience by providing a convenient alternative to hospital-based outpatient procedures.
- In addition to the MOB and ASC, the building will contain Radiology (CT Scan, Fluoroscopy, Ultrasound, Pet Scan and General Radiology) and a Lab Service Center.

## MOB/ASC Details

- Space for multiple physician practices including CNYC, MVHS, etc.
- A six Operating Room (OR) ASC
- The Wynn Hospital will have 14 ORs which brings the total number of ORs to 20; a decrease of two from the two current inpatient hospitals.
- Expected volume shift to outpatient surgery – 5,300 cases

## How does this help the community ?

- **Medical Campus:** The proximity of the building to The Wynn Hospital provides a convenient, medical campus for patients, providers and staff along with almost immediate access for providers to see and/or treat one of their patients in the hospital.
- **Heart Disease:** The developers of the building and one of its main physician offices is CNYC.
- The prevalence of coronary heart disease among adults is high in Mohawk Valley with MVHS as the only cardiac hospital in the eight-county region.
- Outpatient cardiac demand in the Mohawk Valley is expected to grow by nearly 11% between 2022 and 2025. This is versus an anticipated decline in inpatient growth of 10%.

## How does this help the community?

- **Growth:** Having a physician practice such as CNYC in a MOB/ASC next to The Wynn Hospital will bring 30-40,000 patients/year from both local and surrounding counties down to the new medical campus which helps reinforce that important referral pattern and expectation that "this is where they go for medical care."
- With the new MOB/ASC and enhanced cardiac services, CNYC is expecting a 20-30 percent growth
- We are already working in the right direction as the first program in NYS to be designated a "Heart Center" by the American College of Cardiology. The MOB/ASC will provide the opportunity to build on this along with the ability to grow and recruit more highly skilled, well-trained physicians.

## How does this help the community?

- **Physician Recruitment:** The Wynn Hospital and adjacent MOB/ASC is key to physician recruiting. CNYC has successfully recruited three new, well-trained cardiac specialists this year alone. Access to a larger, modern office building with state-of-the-art diagnostic technologies, closely located to the new hospital, is a major draw.
- The training and skills of these newly recruited physicians provides the ability to offer new procedures not currently available in this region, enhancing healthcare and expansion of services to benefit the community.
- **Technology:** CNYC will implement the use of myocardial perfusion positron emission tomography (PET), a noninvasive cardiac imaging option for patients with coronary artery disease. Myocardial perfusion PET has high diagnostic accuracy, high-quality images, low radiation exposure, short acquisition protocols, quantification of myocardial blood flow and strong prognostic power.
- **New Procedure:** CNYC will also implement MitraClip Transcatheter Mitral Valve Repair. MitraClip is a medical device used to treat mitral valve regurgitation for individuals who would not have open-heart surgery. It is implanted via a tri-axial transcatheter technique and involves suturing together the anterior and posterior mitral valve leaflets.

## Financial Benefit to Community

- ASCs provide care in a space that is more efficient and at a lower cost. The move of 5,300 surgery cases to an outpatient setting will pass these savings on to patients as copays for ASCs are much lower than for a hospital-based surgery.
- Payers will also benefit due to the lower reimbursement paid to ASCs vs Hospitals.
- The MOB/ASC will be a tax-paying entity without a requested Pilot. A significant amount of tax revenue will be generated from this building.



## Why is Financial Assistance Needed?

- The cost of construction materials have significantly increased in cost. The pandemic had a major impact on this.
- Delays in construction have also led to increased costs.
- Without the requested financial assistance, the ability to finalize or enhance certain areas may not be possible: purchasing equipment, bringing in additional doctors, or finishing certain spaces in the building.

CENTRAL UTICA BUILDING

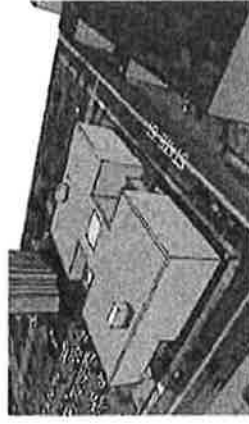
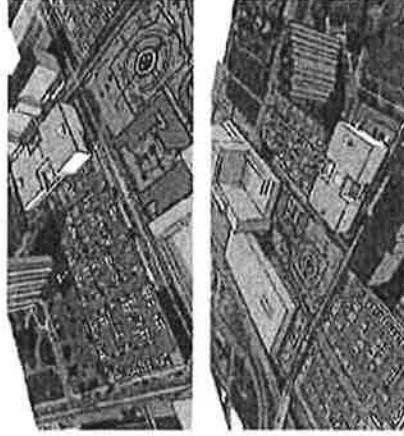

# Layout of The Wynn Hospital

- 373 Beds
- 42 Behavioral Health Beds
- 670,000 F

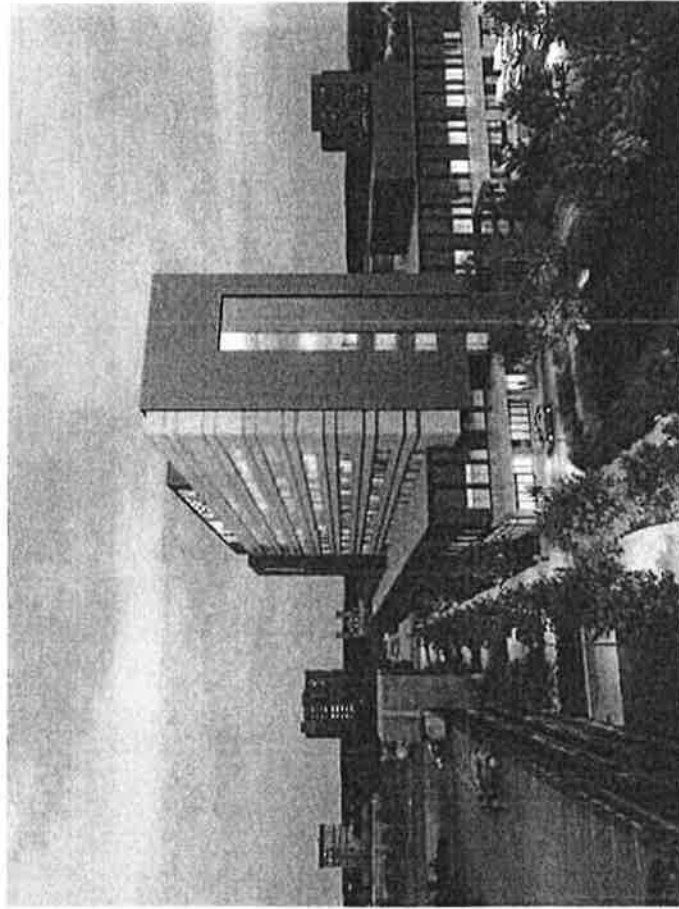
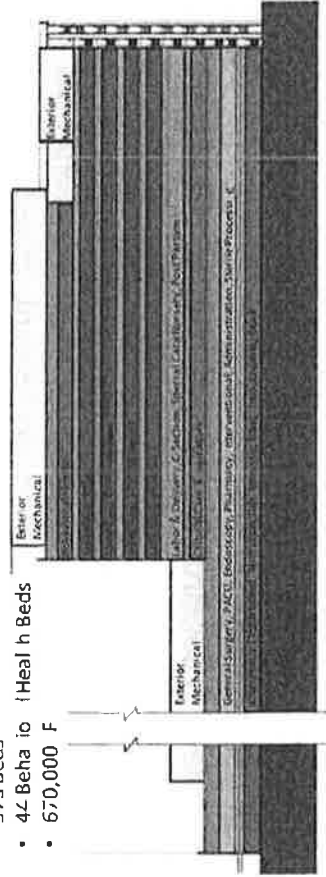

**Ruberto, Laura**

---

**From:** Shawna Papale <spapale@mvedge.org>  
**Sent:** Monday, December 13, 2021 10:24 PM  
**To:** Ruberto, Laura; Mark Levitt; Romano, Linda  
**Subject:** Fwd: FOIL request regarding Central Utica Building, LLC Application for Financial Assistance  
**Attachments:** 2021-12-13 FOIL request to OCIDA.PDF  
**Follow Up Flag:** Follow up  
**Due By:** Monday, January 03, 2022 9:00 AM  
**Flag Status:** Flagged

External Email: Use caution before clicking links or opening attachments.

Shawna Papale  
Sent from my iPhone

Begin forwarded message:

**From:** Patrick Donnelly <pdonnelly@bdflegal.com>  
**Date:** December 13, 2021 at 5:02:56 PM EST  
**To:** Info <info@mvedge.org>, Shawna Papale <spapale@mvedge.org>  
**Cc:** Michael Fogel <mfogel@bdflegal.com>  
**Subject:** FOIL request regarding Central Utica Building, LLC Application for Financial Assistance

Dear FOIL Officer of the Oneida County Industrial Development Agency:

Please see the attached request pursuant to the Freedom of Information Law ("FOIL").

Thank you for your attention to this matter.

*Patrick D. Donnelly, Esq.*  
BROWN DUKE & FOGEL, P.C.  
120 Madison Street, AXA Tower 2, Suite 1620  
Syracuse, New York 13202  
Phone: (315) 399-4343, x206  
Fax: (315) 472-6215  
[pdonnelly@bdflegal.com](mailto:pdonnelly@bdflegal.com)  
<http://bdflegal.com/>

\*\*\*\*\*  
**Confidentiality Notice:** This e-mail transmission (including any attachments) is intended only for the use of the individual or entity to which it is addressed, and may contain information that is privileged, confidential, and exempt from disclosure under applicable law. If you are not the intended recipient, you are hereby notified that any disclosure, copying, distribution, or the taking of any action in reliance on the contents of this e-mail or any attachment is strictly prohibited. If you have received this transmission in error, please immediately notify the sender by return e-mail and delete all copies of this e-mail and any attachments.  
\*\*\*\*\*

CAUTION: This email originated from outside of the organization. Do not click links or open attachments unless you recognize the sender and know the content is safe.

**BROWN DUKE & FOGEL, P.C.**  
ATTORNEYS AND COUNSELORS AT LAW  
WWW.BDFLEGAL.COM

Patrick D. Donnelly, Esq.  
Brown Duke & Fogel, P.C.  
120 Madison Street, Suite 1620  
Syracuse, New York 13202  
[pdonnelly@bdflegal.com](mailto:pdonnelly@bdflegal.com)  
Tel: 315-399-4343

December 13, 2021

**Via Email**

Shawna Papale, Secretary/Executive Director  
Oneida County Industrial Development Agency  
584 Phoenix Drive  
Rome, New York 13441-4105  
[info@mvedge.org](mailto:info@mvedge.org)  
[spapale@mvedge.org](mailto:spapale@mvedge.org)

**Re: FOIL request regarding Central Utica Building, LLC  
Application for Financial Assistance**

Dear Executive Director Papale:

This is a request pursuant to the Freedom of Information Law ("FOIL") for copies of the following public records:

1. Central Utica Building, LLC Application for Financial Assistance (the "Application"), which Application was submitted on or about November 12, 2021 to the Oneida County Industrial Development Agency ("OCIDA").
2. All records relating to the above referenced Application.

The request for all records relating to the above referenced Application includes but is not limited to all submissions of any documents, forms, letters, emails or other records by Central Utica Building, LLC to OCIDA, letters and emails by OCIDA to Central Utica Building, LLC, letters and emails by any person or entity referencing or commenting on the Application, notices, agendas, minutes or any other record related to the Application or involving any aspect of the Application or meetings or hearings related to the Application.

If you deny any of this request, please cite each exemption you feel justifies the denial and notify me of the appeal procedures. Thank you.

Sincerely,  
BROWN DUKE & FOGEL, P.C.

By:   
Patrick D. Donnelly, Esq.

**Inducement Resolution  
Central Utica Building, LLC Facility**

RESOLUTION OF THE ONEIDA COUNTY INDUSTRIAL DEVELOPMENT AGENCY TAKING OFFICIAL ACTION TOWARD APPOINTING CENTRAL UTICA BUILDING, LLC, THE PRINCIPALS OF CENTRAL UTICA BUILDING, LLC, AND/OR AN ENTITY FORMED OR TO BE FORMED ON BEHALF OF ANY OF THE FOREGOING AS AGENT OF THE AGENCY IN CONNECTION WITH A LEASE-LEASEBACK TRANSACTION, AUTHORIZING THE EXECUTION AND DELIVERY OF AN INDUCEMENT AGREEMENT AND MAKING CERTAIN FINDINGS AND DETERMINATIONS WITH RESPECT TO THE PROJECT.

WHEREAS, Central Utica Building, LLC, on behalf of itself and/or the principals of Central Utica Building, LLC, and/or an entity formed or to be formed on behalf of any of the foregoing (collectively, the "Company") has applied to the Oneida County Industrial Development Agency (the "Agency") to enter into a transaction in which the Agency will assist in the construction of an 80,000± square foot state-of-the-art medical office building and appurtenant facilities including parking areas and all infrastructure, utilities and amenities to support the same (collectively, the "Improvements") situated on parcels of land measuring 2.90± acres in the aggregate adjacent to the new Wynn Hospital (the "Wynn Hospital") located at the Corner of State and Columbia Streets, City of Utica, Oneida County, New York (the "Land") and acquisition and installation of equipment in the Improvements (the "Equipment"), all for the purpose of providing a seamless and integrated health care delivery system together with the Wynn Hospital, and to enhance and expand the delivery of health care services to the community (the Land, the Improvements and the Equipment are referred to collectively as the "Facility" and the construction and equipping of the Improvements is referred to as the "Project"); and

WHEREAS, Mohawk Valley Health System ("MVHS") owns three of the parcels comprising the Land and will ground lease the same to the Company pursuant to a Ground Lease (the "Ground Lease") with a term of 99 years; and

WHEREAS, to accommodate the parking requirements for the Facility, the Company must acquire an interest in the property located at 411 Columbia Street (the "O'Brien Parcel") in order for the Project to proceed; and

WHEREAS, the Company will undertake the Project on the Land, and will lease the Facility to the Agency, pursuant to Article 18-A of the General Municipal Law of the State of New York and Chapter 372 of the Laws of 1970 of the State of New York, as may be amended from time to time (collectively, the "Act"); and

WHEREAS, the Agency will lease the Facility back to the Company pursuant to a Leaseback Agreement (the "Leaseback Agreement"); and

WHEREAS, the Company will sublease a 20,000± square foot portion of the Facility (the "CNYC Facility") to Central New York Cardiology, P.C. (the "CNYC Sublessee") for its operation pursuant to a sublease agreement (the "CNYC Sublease Agreement"); and

WHEREAS, the CNYC Sublessee intends to occupy and build out the CNYC Facility for the purpose of performing interventional cardiology services at the Wynn Hospital and to take cardiology call and provide cardiology services to patients admitted to the Wynn Hospital; and

WHEREAS, the Company will sublease an 18,000± square foot portion of the Facility (the "MVASC Facility") to Mohawk Valley ASC, LLC (the "MVASC Sublessee") for its operation pursuant to a sublease agreement (the "MVASC Sublease Agreement"); and

WHEREAS, the MVASC Sublessee intends to occupy and build out the MVASC Facility for the purpose of operating an Article 28 licensed, Medicare certified multi-specialty ambulatory surgery center with six operating rooms; and

WHEREAS, the Company will sublease other portions of the Facility to MVHS and other medical practices whose physicians practice in, and need access to, the Wynn Hospital, and to other commercial and/or retail tenants to provide complementary services (such sublessees, together with the CNYC Sublessee and the MVASC Sublessee, are referred to collectively as the "Sublessees"); and

WHEREAS, the Act authorizes and empowers the Agency to promote, develop, encourage and assist projects such as the Facility and to advance the job opportunities, health, general prosperity and economic welfare of the people of the State of New York; and

WHEREAS, the Agency contemplates that it will provide financial assistance to the Company in the form of exemptions from sales and use taxes and exemptions from mortgage recording taxes (the "Financial Assistance"); and

WHEREAS, based upon representations made by the Company in the Application, the value of the Financial Assistance requested by the Company is described as follows:

- Sales and use tax exemption estimated at \$1,820,000 not to exceed \$2,002,000
- Mortgage tax exemption estimated at \$128,138 not to exceed \$140,951,

which Financial Assistance is consistent with the Agency's Uniform Tax Exemption Policy; and

WHEREAS, the Agency proposes to amend the value of the Financial Assistance as follows:

- Sales and use tax exemption not to exceed \$500,000
- Mortgage tax exemption estimated at \$128,138 not to exceed \$140,951,

which financial assistance is a deviation from the Agency's Uniform Tax Exemption Policy, and which will be more particularly set forth in a final authorizing resolution; and

WHEREAS, the Company has committed to create (or cause the Sublessees to create) 14 FTEs at the Facility by the end of the third lease year as a result of the Project and to retain (or cause the Sublessees to retain) the existing 146.5 FTEs at the Facility as a result of the Project, and the Agency will condition the proposed financial assistance on the Company achieving the same and maintaining all FTEs for the full lease term, or be subject to termination or recapture of financial assistance; and

WHEREAS, prior to the closing of a lease-leaseback transaction, and the granting of any Financial Assistance, a public hearing (the "Hearing") will be held so that all persons with views in favor of or opposed to either the financial assistance contemplated by the Agency, or the location or nature of the Facility, can be heard; and

WHEREAS, notice of the Hearing will be given prior to the closing of a lease-leaseback transaction, and the granting of any tax benefits, and such notice (together with proof of publication) will be substantially in the form annexed hereto as Exhibit A-1; and

WHEREAS, the minutes of the Hearing are or will be annexed hereto as Exhibit B-1; and

WHEREAS, prior to the closing of a lease-leaseback transaction and the granting of any Financial Assistance and following the Hearing, the Agency will adopt a

Statement of Findings pursuant to the provisions of Section 862(2) of the Act (the "Retail Findings") and will request the County Executive of Oneida County to confirm in writing his approval of the Financial Assistance (the "County Executive Approval"); and

WHEREAS, the Agency has given due consideration to the application of the Company and to representations by the Company that the proposed lease-leaseback transaction is either an inducement to the Company to maintain and expand the Facility in the County or is necessary to maintain the competitive position of the Company in its industry; and

WHEREAS, pursuant to Article 8 of the Environmental Conservation Law and the regulations adopted pursuant thereto by the Department of Environmental Conservation of the State of New York (collectively, the "SEQR Act" or "SEQRA"), the Agency constitutes a "State Agency"; and

WHEREAS, to aid the Agency in determining whether the Facility may have a significant effect upon the environment, the Company has prepared and submitted to the Agency an Environmental Assessment Form and related documents (the "Questionnaire") with respect to the Facility, a copy of which is on file at the office of the Agency; and

WHEREAS, prior to the granting of any Financial Assistance and following the determination of the lead agency, the Agency will complete its environmental review and make determinations for purposes of SEQRA.

NOW, THEREFORE, BE IT RESOLVED by the Oneida County Industrial Development Agency (a majority of the members thereof affirmatively concurring) that:

- Section 1.
- (a) The construction and equipping of the Facility and the Agency's Financial Assistance therefor, will promote job opportunities, health, general prosperity and the economic welfare of the inhabitants of the County and the people of the State of New York and improve their standard of living, and thereby serve the public purposes of the Act and the same is, therefore, approved.
  - (b) It is desirable and in the public interest for the Agency to enter into a lease-leaseback transaction for the purpose of providing financial assistance for the construction and equipping of the Facility, as reflected in the Company's application to the Agency and as amended from time to time prior to the closing of the lease-leaseback transaction.



Section 2.

The form and substance of a proposed inducement agreement (in substantially the form presented to this meeting) by and between the Agency and the Company setting forth the undertakings of the Agency and the Company with respect to the closing of the lease-leaseback transaction, and the development of the Facility (the "Agreement") is hereby approved. The Chairman of the Agency is hereby authorized, on behalf of the Agency, to execute and deliver the Agreement, with such changes in terms and form as the Chairman shall approve. The execution thereof by the Chairman shall constitute conclusive evidence of such approval.

Section 3.

The Agency shall assist the Company in the construction and equipping of the Facility and will provide financial assistance with respect thereto subject to (i) obtaining all necessary governmental approvals, (ii) approval of the members of the Company, (iii) approval of the members of the Agency, (iv) the Agency adopting the Retail Findings and obtaining the County Executive Approval; (v) satisfactory completion of the environmental review of the Facility by the Agency in compliance with the State Environmental Quality Review Act, (vi) agreement by the Agency and the Company upon mutually acceptable terms and conditions for the Leaseback Agreement and other documentation usual and customary to transactions of this nature, (vii) the condition that there are no changes in New York State Law which prohibit or limit the Agency from fulfilling its obligation and commitment as herein set forth to enter into the lease-leaseback transaction and (viii) payment by the Company of the Agency's transaction fee and the fees and disbursements of transaction counsel and agency counsel, more particularly described in the Inducement Agreement.

Section 4.

The Company is herewith and hereby appointed the agent of the Agency to construct, equip and complete the Facility. The Company is hereby empowered to delegate its status as agent of the Agency to the agents, subagents, contractors, subcontractors, materialmen, suppliers, vendors and such other parties as the Company may choose in order to construct, equip and complete the Facility. The terms and conditions for the appointment of the Company as agent of the Agency for the purposes described in this resolution are set forth in the form of the attached letter addressed to the Company, marked as **Exhibit C** to this resolution. The form of such letter is incorporated herein by reference and is approved and adopted by the Agency, and the Chairman or Executive Director of the Agency

or any other duly authorized official of the Agency are authorized to execute and deliver such letter to the Company upon satisfaction of the conditions described in Section 3 hereof. The Agency hereby appoints the Company, the agents, subagents, contractors, subcontractors, materialmen, vendors and suppliers of the Company as agents of the Agency solely for purposes of making sales or leases of goods, services, and supplies to the Facility, and any such transaction between any agent, subagent, contractor, subcontractor, materialmen, vendor or supplier, and the Company, as agent of the Agency shall be deemed to be on behalf of the Agency and for the benefit of the Facility. The Company shall indemnify the Agency with respect to any transaction of any kind between and among the Company, the Sublessees, the agents, subagents, contractors, subcontractors, materialmen, vendors and/or suppliers and the Company, as agent of the Agency.

Section 5. The Agency is hereby authorized and directed to schedule the Hearing, so that the Agency may receive comments from all interested parties on the financial assistance contemplated by the Agency and the financial assistance requested by the Company.

Section 6. The law firm of Bond, Schoeneck & King, PLLC is appointed Transaction Counsel in connection with the lease-leaseback transaction.

Section 7. Counsel to the Agency and Transaction Counsel are hereby authorized to work with counsel to the Company and others to prepare, for submission to the Agency, all documents necessary to effect the lease-leaseback transaction.

Section 8. The Chairman of the Agency is hereby authorized and directed (i) to distribute copies of this resolution to the Company and (ii) to do such further things or perform such acts as may be necessary or convenient to implement the provisions of this resolution.

Section 9. This resolution shall take effect immediately.

The above resolution was AMENDED on December 17, 2021 as follows:

WHEREAS, on November 19, 2021 the Oneida County Industrial Development Agency (the "Agency") adopted a resolution granting preliminary approval for financial assistance to Central Utica Building, LLC (the "Company") consisting of exemptions from sales and use tax not to exceed \$500,000 and exemptions from mortgage recording tax estimated at \$128,138 not to exceed \$140,951 (collectively, the "Financial Assistance"); and

WHEREAS, on December 10, 2021 the Agency conducted a public hearing regarding the proposed Financial Assistance and the nature and location of the Facility; and

WHEREAS, the Agency members were provided with the minutes of the Public Hearing and all written and verbal comments for and against the Project; and

WHEREAS, the Company submitted a letter dated December 10, 2021 requesting the Agency reconsider its limitation on the sales tax exemption contained in the resolution adopted on November 19, 2021, and requesting the opportunity to make a presentation to the Agency to support its request; and

WHEREAS, as a supplement to its Application for Financial Assistance (the "Application"), the Company presented new information to the Agency regarding the Project including (a) new renderings of the Facility that were not available at the time the Application was submitted, which renderings show that the proposed building has grown from 80,000 square feet to 94,000 square feet and the added cost has not been incorporated into the requested sales tax exemption; (b) the importance of the Facility being operational prior to the completion of the Wynn Hospital so that sufficient surgical capacity is in place; (c) the unprecedented size of the private sector investment; (d) the significant number of new patients the CNYC Sublessee will attract to the Facility; (e) the American College of Cardiology has recognized MVHS as the first Heart Center in New York State, which demonstrates the quality of heart care locally; (f) the Facility will provide critical modern technology and services, while providing care in a lower cost setting; (g) the Facility will be used as a recruiting tool to help attract high-quality doctors to the region; (h) the impact of price increases and supply chain disruptions on the feasibility of the Project; and (i) the fact that the CNYC Sublessee has outgrown its current facility, and the possibility that the CNYC Sublessee will relocate outside of the region if the Project does not proceed; and

WHEREAS, the Agency has given due consideration to the supplemental information and to the comments received at the December 10, 2021 public hearing.

NOW, THEREFORE, BE IT RESOLVED by the Oneida County Industrial Development Agency (a majority of the members thereof affirmatively concurring) that:

**RESOLVED:** the Agency accepts the information presented by the Company as an amendment and supplement to its Application; and

**RESOLVED:** that the Agency proposes to amend the value of the Financial Assistance as follows:

- Sales and use tax exemption estimated at \$1,820,000 not to exceed \$2,002,000
- Mortgage tax exemption estimated at \$128,138 not to exceed \$140,951,

which amended Financial Assistance is consistent with the Agency's Uniform Tax Exemption Policy; and

**RESOLVED:** prior to the closing of a lease-leaseback transaction, and the granting of any amended Financial Assistance, a new public hearing (the "Hearing") will be held so that all persons with views in favor of or opposed to either the amended Financial Assistance contemplated by the Agency, or the location or nature of the Facility, can be heard; and

**RESOLVED:** notice of the Hearing will be given prior to the closing of a lease-leaseback transaction, and the granting of any amended Financial Assistance, and such notice (together with proof of publication) will be substantially in the form annexed hereto as Exhibit A-2; and

**RESOLVED:** the minutes of the Hearing are or will be annexed hereto as Exhibit B-2; and

**RESOLVED:** the form of agency appointment letter attached as Exhibit C shall be revised to reflect the amended Financial Assistance; and

**RESOLVED:** prior to the closing of a lease-leaseback transaction and the granting of any Financial Assistance and following the Hearing, the Agency will adopt a Statement of Findings pursuant to the provisions of Section 862(2) of the Act (the "Retail Findings") and will request the County Executive of Oneida County to confirm in writing his approval of the Financial Assistance (the "County Executive Approval"); and

**RESOLVED:** this resolution shall take effect immediately.

STATE OF NEW YORK    )  
                                  : ss.:  
COUNTY OF ONEIDA    )

I, the undersigned Secretary of the Oneida County Industrial Development Agency DO HEREBY CERTIFY THAT:

I have compared the foregoing copy of a resolution of the Oneida County Industrial Development Agency (the "Agency"), with the original thereof on file in the office of the Agency, and that the same is a true and correct copy of such resolution and of the proceedings of the Agency in connection with such matter.

Such resolution was passed at a meeting of the Agency duly convened in public session on November 19, 2021 at eight a.m., local time, at Rome, New York which the following members were:

Members Present: David Grow, Michael Fitzgerald, Kirk Hinman, Eugene Quadraro, Steven Zogby

Members Webex/Teleconference: Ferris Betrus

Members Excused: Mary Faith Messenger

The question of the adoption of the foregoing resolution was duly put to vote, which resulted as follows:

	Aye	Nay	Abstain
Ferris Betrus	<u>  X  </u>	<u>      </u>	<u>      </u>
Michael Fitzgerald	<u>  X  </u>	<u>      </u>	<u>      </u>
David Grow	<u>  X  </u>	<u>      </u>	<u>      </u>
Kirk Hinman	<u>  X  </u>	<u>      </u>	<u>      </u>
Eugene Quadraro	<u>  X  </u>	<u>      </u>	<u>      </u>
Steve Zogby	<u>  X  </u>	<u>      </u>	<u>      </u>

and, therefore, the resolution was declared duly adopted.

The Agreement and the Application are in substantially the form presented to and approved at such meeting.

I have also compared the foregoing copy of an amended resolution of the Oneida County Industrial Development Agency (the "Agency"), with the original thereof on file in the office of the Agency, and that the same is a true and correct copy of such resolution and of the proceedings of the Agency in connection with such matter.

Such amended resolution was passed at a meeting of the Agency duly convened in public session on December 17, 2021 at eight a.m., local time, at Rome, New York which the following members were:

Members Present: David Grow, Kirk Hinman, Steven Zogby

Members Webex/Teleconference: Ferris Betrus, Mary Faith Messenger, Eugene Quadraro

Members Excused: Michael Fitzgerald

The question of the adoption of the foregoing resolution was duly put to vote, which resulted as follows:

	Aye	Nay	Abstain
Ferris Betrus	<u>  X  </u>	<u>      </u>	<u>      </u>
David Grow	<u>  X  </u>	<u>      </u>	<u>      </u>
Kirk Hinman	<u>  X  </u>	<u>      </u>	<u>      </u>
Mary Faith Messenger	<u>  X  </u>	<u>      </u>	<u>      </u>
Eugene Quadraro	<u>  X  </u>	<u>      </u>	<u>      </u>
Steve Zogby	<u>  X  </u>	<u>      </u>	<u>      </u>

and, therefore, the amended resolution was declared duly adopted.

The Agreement and the Application are in substantially the form presented to and approved at such meeting.

I FURTHER CERTIFY that (i) all members of the Agency had due notice of said meetings, (ii) said meetings were open for the public to attend and public notice of the time, place of, and instructions to access, said meetings was duly given, (iii) the meetings in all respects were duly held, and (iv) there was a quorum present throughout.

IN WITNESS WHEREOF, I have hereunto set my hand this \_\_\_\_\_ day of \_\_\_\_\_ 2022.

\_\_\_\_\_  
Shawna Papale, Secretary

## EXHIBIT A-1

### NOTICE OF PUBLIC HEARING

NOTICE IS HEREBY GIVEN that a public hearing pursuant to Article 18-A of the New York State General Municipal Law, will be held by the Oneida County Industrial Development Agency (the "Agency") on the 10th day of December 2021 at 10:00 a.m., local time, at Oneida County Legislative Chambers, 8<sup>th</sup> Floor, Oneida County Office Building, 800 Park Avenue, City of Utica, New York in connection with the following matters:

Central Utica Building, LLC, on behalf of itself and/or the principals of Central Utica Building, LLC, and/or an entity formed or to be formed on behalf of any of the foregoing (collectively, the "Company") has applied to the Oneida County Industrial Development Agency (the "Agency") to enter into a transaction in which the Agency will assist in the construction of an 80,000± square foot state-of-the-art medical office building and appurtenant facilities including parking areas and all infrastructure, utilities and amenities to support the same (collectively, the "Improvements") situated on parcels of land measuring 2.90± acres in the aggregate adjacent to the new Wynn Hospital (the "Wynn Hospital") located at the Corner of State and Columbia Streets, City of Utica, Oneida County, New York (the "Land") and acquisition and installation of equipment in the Improvements (the "Equipment"), all for the purpose of providing a seamless and integrated health care delivery system together with the Wynn Hospital, and to enhance and expand the delivery of health care services to the community (the Land, the Improvements and the Equipment are referred to collectively as the "Facility" and the construction and equipping of the Improvements is referred to as the "Project"). The Facility will be initially operated and/or managed by the Company.

The Company will lease the Facility to the Agency, and the Agency will lease the Facility back to the Company pursuant to a leaseback agreement. At the end of the lease term, the Agency will terminate its leasehold interest in the Facility. The Company will sublease a 20,000± square foot portion of the Facility to Central New York Cardiology, P.C. (the "CNYC Sublessee") for its operation for the purpose of performing interventional cardiology services at the Wynn Hospital and to take cardiology call and provide cardiology services to patients admitted to the Wynn Hospital. The Company will sublease an 18,000± square foot portion of the Facility to Mohawk Valley ASC, LLC (the "MVASC Sublessee") for its operation for the purpose of operating an Article 28 licensed, Medicare certified multi-specialty ambulatory surgery center with six operating rooms. The Company will sublease other portions of the Facility to MVHS and other medical practices whose physicians practice in, and need access to, the Wynn Hospital, and to other commercial and/or retail tenants to provide complementary services (such sublessees, together with the CNYC Sublessee and the MVASC Sublessee, are referred to collectively as the "Sublessees").



The Agency is contemplating providing financial assistance in the form of exemptions from mortgage recording taxes and exemptions from sales tax on materials and equipment acquired and installed in connection with the Project, such sales tax exemptions to be limited to \$500,000, which financial assistance is a deviation from the Agency's Uniform Tax Exemption Policy, to be more particularly described in a Final Authorizing Resolution to be adopted by the Agency prior to the closing of the transactions described herein. Such financial assistance will be conditioned upon the Company creating, retaining and maintaining (or causing the Sublessees to create, retain and maintain) certain employment at the Facility as a result of undertaking the Project.

A representative of the Agency will at the above-stated time and place hear and accept written comments from all persons with views in favor of or opposed to either the proposed financial assistance to the Company or the location or nature of the Facility. Comments may also be submitted to the Agency in writing or electronically prior to the Public Hearing. Members of the public may also access the Public Hearing and comment on the Project and the benefits to be granted to the Applicant by the Agency during the Public Hearing by calling 1-408-418-9388 (Access code: \_\_\_\_\_). Minutes of the Public Hearing will be transcribed and posted on the Agency's website. A copy of the Application for Financial Assistance filed by the Company with the Agency, including an analysis of the costs and benefits of the proposed Project, is available for public inspection at the offices of the Agency, 584 Phoenix Drive, Rome, New York.

ONEIDA COUNTY INDUSTRIAL  
DEVELOPMENT AGENCY

Dated: November 19, 2021

By: /s/ Shawna M. Papale, Executive Director

## **EXHIBIT A-2**

### **NOTICE OF PUBLIC HEARING**

NOTICE IS HEREBY GIVEN that a public hearing pursuant to Article 18-A of the New York State General Municipal Law, will be held by the Oneida County Industrial Development Agency (the "Agency") on the 18th day of January 2022 at 10:00 a.m., local time, at Oneida County Legislative Chambers, 10<sup>th</sup> Floor, Oneida County Office Building, 800 Park Avenue, Utica, New York in connection with the following matters:

Central Utica Building, LLC, on behalf of itself and/or the principals of Central Utica Building, LLC, and/or an entity formed or to be formed on behalf of any of the foregoing (collectively, the "Company") has applied to the Oneida County Industrial Development Agency (the "Agency") to enter into a transaction in which the Agency will assist in the construction of a 94,000± square foot state-of-the-art medical office building and appurtenant facilities including parking areas and all infrastructure, utilities and amenities to support the same (collectively, the "Improvements") situated on parcels of land measuring 2.90± acres in the aggregate adjacent to the new Wynn Hospital (the "Wynn Hospital") located at the Corner of State and Columbia Streets, City of Utica, Oneida County, New York (the "Land") and acquisition and installation of equipment in the Improvements (the "Equipment"), all for the purpose of providing a seamless and integrated health care delivery system together with the Wynn Hospital, and to enhance and expand the delivery of health care services to the community (the Land, the Improvements and the Equipment are referred to collectively as the "Facility" and the construction and equipping of the Improvements is referred to as the "Project"). The Facility will be initially operated and/or managed by the Company.

The Company will lease the Facility to the Agency, and the Agency will lease the Facility back to the Company pursuant to a leaseback agreement. At the end of the lease term, the Agency will terminate its leasehold interest in the Facility. The Company will sublease a 20,000± square foot portion of the Facility to Central New York Cardiology, P.C. (the "CNYC Sublessee") for its operation for the purpose of performing interventional cardiology services at the Wynn Hospital, to take cardiology call and provide cardiology services to patients admitted to the Wynn Hospital. The Company will sublease an 18,000± square foot portion of the Facility to Mohawk Valley ASC, LLC (the "MVASC Sublessee") for its operation for the purpose of operating an Article 28 licensed, Medicare certified multi-specialty ambulatory surgery center with six operating rooms. The Company will sublease other portions of the Facility to MVHS and other medical practices whose physicians practice in, and need access to, the Wynn Hospital, and to other commercial and/or retail tenants to provide complementary services (such sublessees, together with the CNYC Sublessee and the MVASC Sublessee, are referred to collectively as the "Sublessees").

The Agency was contemplating providing financial assistance in the form of exemptions from mortgage recording taxes and exemptions from sales tax on materials and equipment acquired and installed in connection with the Project, such sales tax exemption limited to \$500,000, which financial assistance was a deviation from the Agency's Uniform Tax Exemption Policy (the "Policy"). The Agency conducted a public hearing on December 10, 2021 to hear and accept written comments from all persons with views in favor of or opposed to either the proposed financial assistance or the location or nature of the Facility. The Agency is now contemplating providing financial assistance in the form of exemptions from mortgage recording taxes and exemptions from sales tax on all taxable materials and equipment acquired and installed in connection with the Project, which financial assistance is consistent with the Policy, to be more particularly described in a Final Authorizing Resolution to be adopted by the Agency prior to the closing of the transactions described herein. Such financial assistance will be conditioned upon the Company creating, retaining and maintaining (or causing the Sublessees to create, retain and maintain) certain employment at the Facility as a result of undertaking the Project.

A representative of the Agency will at the above-stated time and place hear and accept written comments from all persons with views in favor of or opposed to either the proposed amended financial assistance or the location or nature of the Facility. Comments may also be submitted to the Agency in writing or electronically prior to the Public Hearing. Members of the public may listen to the Public Hearing by calling 1-408-418-9388 (Access code: 263 489 89116). Minutes of the Public Hearing will be transcribed and posted on the Agency's website. A copy of the Application for Financial Assistance filed by the Company with the Agency, including an analysis of the costs and benefits of the proposed Project, is available for public inspection at the offices of the Agency, 584 Phoenix Drive, Rome, New York.

ONEIDA COUNTY INDUSTRIAL  
DEVELOPMENT AGENCY

Dated: January 4, 2022

By: /s/ Shawna M. Papale, Executive Director

EXHIBIT B-1

**MINUTES OF DECEMBER 10, 2021 PUBLIC HEARING**

Oneida County Industrial Development Agency  
Lease-Leaseback Transaction  
Central Utica Building, LLC Facility

1. Jennifer Waters, Assistant Secretary of the Oneida County Industrial Development Agency (the "Agency"), called the hearing to order at 10:00 a.m.
2. Mark Kaucher, a representative of the Agency, recorded the minutes of the hearing.
3. The Assistant Secretary then described the proposed project and related financial assistance as follows:

Central Utica Building, LLC, on behalf of itself and/or the principals of Central Utica Building, LLC, and/or an entity formed or to be formed on behalf of any of the foregoing (collectively, the "Company") has applied to the Oneida County Industrial Development Agency (the "Agency") to enter into a transaction in which the Agency will assist in the construction of an 80,000± square foot state-of-the-art medical office building and appurtenant facilities including parking areas and all infrastructure, utilities and amenities to support the same (collectively, the "Improvements") situated on parcels of land measuring 2.90± acres in the aggregate adjacent to the new Wynn Hospital (the "Wynn Hospital") located at the corner of State and Columbia Streets, City of Utica, Oneida County, New York (the "Land") and acquisition and installation of equipment in the Improvements (the "Equipment"), all for the purpose of providing a seamless and integrated health care delivery system together with the Wynn Hospital, and to enhance and expand the delivery of health care services to the community (the Land, the Improvements and the Equipment are referred to collectively as the "Facility" and the construction and equipping of the Improvements is referred to as the "Project"). The Facility will be initially operated and/or managed by the Company.

The Company will lease the Facility to the Agency, and the Agency will lease the Facility back to the Company pursuant to a leaseback agreement. At the end of the lease term, the Agency will terminate its leasehold interest in the Facility. The Company will sublease a 20,000± square foot portion of the Facility (the "CNYC Facility") to Central New York Cardiology, P.C. (the "CNYC Sublessee") for its operation for the

purpose of performing interventional cardiology services at the Wynn Hospital and to take cardiology call and provide cardiology services to patients admitted to the Wynn Hospital. The Company will sublease an 18,000± square foot portion of the Facility (the "MVASC Facility") to Mohawk Valley ASC, LLC (the "MVASC Sublessee") for its operation for the purpose of operating an Article 28 licensed, Medicare certified multi-specialty ambulatory surgery center with six operating rooms. The Company will sublease other portions of the Facility to MVHS and other medical practices whose physicians practice in, and need access to, the Wynn Hospital, and to other commercial and/or retail tenants to provide complementary services (such sublessees, together with the CNYC Sublessee and the MVASC Sublessee, are referred to collectively as the "Sublessees").

The Agency is contemplating providing financial assistance in the form of exemptions from mortgage recording taxes and exemptions from sales tax on materials and equipment acquired and installed in connection with the Project, which financial assistance is consistent with the Agency's Uniform Tax Exemption Policy, to be more particularly described in a Final Authorizing Resolution to be adopted by the Agency prior to the closing of the transactions described herein. Such financial assistance will be conditioned upon the Company creating, retaining and maintaining (or causing the Sublessees to create, retain and maintain) certain employment at the Facility as a result of undertaking the Project.

4. The Assistant Secretary then opened up the hearing for comments from the floor for or against the proposed financial assistance and the location and nature of the Facility. Attached is a listing of the persons heard and a summary of their views as well as all written comments submitted for consideration.
5. The Assistant Secretary then asked if there were any further comments, and, there being none, the hearing was closed at 10:24 a.m.

---

Mark Kaucher

STATE OF NEW YORK        )  
                                  : SS.:  
COUNTY OF ONEIDA        )

I, the undersigned Secretary of the Oneida County Industrial Development Agency, DO HEREBY CERTIFY:

That I have compared the foregoing copy of the minutes of a public hearing held by the Oneida County Industrial Development Agency (the "Agency") on December 10, 2021 at 10:00 a.m. local time, at Oneida County Legislative Chambers, 8<sup>th</sup> Floor, Oneida County Office Building, 800 Park Avenue, City of Utica, New York, with the original thereof on file in the office of the Agency, and that the same is a true and correct copy of the minutes in connection with such matter.

I FURTHER CERTIFY that (i) the public hearing was open for the public to attend and public notice of said hearing was duly given, (ii) the hearing in all respects was duly held, and (iii) members of the public had an opportunity to be heard.

IN WITNESS WHEREOF, I have hereunto set my hand as of \_\_\_\_\_, 2021.

\_\_\_\_\_  
Secretary

EXHIBIT B-2

**MINUTES OF JANUARY 18, 2022 PUBLIC HEARING**

Oneida County Industrial Development Agency  
Lease-Leaseback Transaction  
Central Utica Building, LLC Facility

1. Jennifer Waters, Assistant Secretary of the Oneida County Industrial Development Agency (the "Agency"), called the hearing to order at 10:00 a.m.
2. Mark Kaucher, a representative of the Agency, recorded the minutes of the hearing.
3. The Assistant Secretary then described the proposed project and related financial assistance as follows:

Central Utica Building, LLC, on behalf of itself and/or the principals of Central Utica Building, LLC, and/or an entity formed or to be formed on behalf of any of the foregoing (collectively, the "Company") has applied to the Oneida County Industrial Development Agency (the "Agency") to enter into a transaction in which the Agency will assist in the construction of a 94,000± square foot state-of-the-art medical office building and appurtenant facilities including parking areas and all infrastructure, utilities and amenities to support the same (collectively, the "Improvements") situated on parcels of land measuring 2.90± acres in the aggregate adjacent to the new Wynn Hospital (the "Wynn Hospital") located at the Corner of State and Columbia Streets, City of Utica, Oneida County, New York (the "Land") and acquisition and installation of equipment in the Improvements (the "Equipment"), all for the purpose of providing a seamless and integrated health care delivery system together with the Wynn Hospital, and to enhance and expand the delivery of health care services to the community (the Land, the Improvements and the Equipment are referred to collectively as the "Facility" and the construction and equipping of the Improvements is referred to as the "Project"). The Facility will be initially operated and/or managed by the Company.

The Company will lease the Facility to the Agency, and the Agency will lease the Facility back to the Company pursuant to a leaseback agreement. At the end of the lease term, the Agency will terminate its leasehold interest in the Facility. The Company will sublease a 20,000± square foot portion of the Facility to Central New York Cardiology, P.C. (the "CNYC Sublessee") for its operation for the purpose of performing interventional cardiology services at the Wynn Hospital, to take cardiology call and provide cardiology services to patients admitted to

the Wynn Hospital. The Company will sublease an 18,000± square foot portion of the Facility to Mohawk Valley ASC, LLC (the "MVASC Sublessee") for its operation for the purpose of operating an Article 28 licensed, Medicare certified multi-specialty ambulatory surgery center with six operating rooms. The Company will sublease other portions of the Facility to MVHS and other medical practices whose physicians practice in, and need access to, the Wynn Hospital, and to other commercial and/or retail tenants to provide complementary services (such sublessees, together with the CNYC Sublessee and the MVASC Sublessee, are referred to collectively as the "Sublessees").

The Agency was contemplating providing financial assistance in the form of exemptions from mortgage recording taxes and exemptions from sales tax on materials and equipment acquired and installed in connection with the Project, such sales tax exemption limited to \$500,000, which financial assistance was a deviation from the Agency's Uniform Tax Exemption Policy (the "Policy"). The Agency conducted a public hearing on December 10, 2021 to hear and accept written comments from all persons with views in favor of or opposed to either the proposed financial assistance or the location or nature of the Facility. The Agency is now contemplating providing financial assistance in the form of exemptions from mortgage recording taxes and exemptions from sales tax on all taxable materials and equipment acquired and installed in connection with the Project, which financial assistance is consistent with the Policy, to be more particularly described in a Final Authorizing Resolution to be adopted by the Agency prior to the closing of the transactions described herein. Such financial assistance will be conditioned upon the Company creating, retaining and maintaining (or causing the Sublessees to create, retain and maintain) certain employment at the Facility as a result of undertaking the Project.

4. The Assistant Secretary then opened up the hearing for comments from the floor for or against the proposed financial assistance and the location and nature of the Facility. Attached is a listing of the persons heard and a summary of their views as well as all written comments submitted for consideration.
5. The Assistant Secretary then asked if there were any further comments, and, there being none, the hearing was closed at \_\_\_\_\_ a.m.

---

Mark Kaucher



STATE OF NEW YORK        )  
                                      : SS.:  
COUNTY OF ONEIDA        )

I, the undersigned Secretary of the Oneida County Industrial Development Agency, DO HEREBY CERTIFY:

That I have compared the foregoing copy of the minutes of a public hearing held by the Oneida County Industrial Development Agency (the "Agency") on December 10, 2021 at 10:00 a.m. local time, at Oneida County Legislative Chambers, 8<sup>th</sup> Floor, Oneida County Office Building, 800 Park Avenue, City of Utica, New York, with the original thereof on file in the office of the Agency, and that the same is a true and correct copy of the minutes in connection with such matter.

I FURTHER CERTIFY that (i) the public hearing was open for the public to attend and public notice of said hearing was duly given, (ii) the hearing in all respects was duly held, and (iii) members of the public had an opportunity to be heard.

IN WITNESS WHEREOF, I have hereunto set my hand as of \_\_\_\_\_, 2021.

---

Secretary

EXHIBIT C

[To be printed on IDA letterhead and delivered to the Company when appropriate]

\_\_\_\_\_, 2022

Central Utica Building, LLC  
Attn.: David Quirello  
2211 Genesee Street  
Utica, New York 13501

RE: *Oneida County Industrial Development Agency Lease-Leaseback Transaction  
Central Utica Building, LLC Facility*

Dear Mr. Quirello:

Pursuant to a resolution duly adopted on November 19, 2021 and amended on December 17, 2021, Oneida County Industrial Development Agency (the "Agency") appointed Central Utica Building, LLC (the "Company") its agent in connection with a transaction in which the Agency will assist in the construction of an 94,000± square foot state-of-the-art medical office building and appurtenant facilities including parking areas and all infrastructure, utilities and amenities to support the same (collectively, the "Improvements") situated on parcels of land measuring 2.90± acres in the aggregate adjacent to the new Wynn Hospital (the "Wynn Hospital") located at the corner of State and Columbia Streets, City of Utica, Oneida County, New York (the "Land") and acquisition and installation of equipment in the Improvements (the "Equipment"), all for the purpose of providing a seamless and integrated health care delivery system together with the Wynn Hospital, and to enhance and expand the delivery of health care services to the community (the Land, the Improvements and the Equipment are referred to collectively as the "Facility" and the construction and equipping of the Improvements is referred to as the "Project"). The Company will lease the Facility to the Agency and the Agency will lease the Facility back to the Company pursuant to a Leaseback Agreement. The Company will sublease a 20,000± square foot portion of the Facility (the "CNYC Facility") to Central New York

Cardiology, P.C. (the "CNYC Sublessee") for its operation for the purpose of performing interventional cardiology services at the Wynn Hospital and to take cardiology call and provide cardiology services to patients admitted to the Wynn Hospital. The Company will sublease an 18,000± square foot portion of the Facility (the "MVASC Facility") to Mohawk Valley ASC, LLC (the "MVASC Sublessee") for its operation for the purpose of operating an Article 28 licensed, Medicare certified multi-specialty ambulatory surgery center with six operating rooms. The Company will sublease other portions of the Facility to MVHS and other medical practices whose physicians practice in, and need access to, the Wynn Hospital, and to other commercial and/or retail tenants to provide complementary services (such sublessees, together with the CNYC Sublessee and the MVASC Sublessee, are referred to collectively as the "Sublessees").

This appointment includes authority to purchase on behalf of the Agency all materials to be incorporated into and made an integral part of the Facility, and the following activities as they relate to any construction, equipping and completion of any buildings, whether or not any materials, equipment or supplies described below are incorporated into or become an integral part of such buildings: (i) all purchases, leases, rentals and other uses of tools, machinery and equipment in connection with construction and equipping (ii) all purchases, rentals, uses or consumption of supplies, materials and services of every kind and description used in connection with construction and equipping and (iii) all purchases, leases, rentals and uses of equipment, machinery, and other tangible personal property (including installation costs), installed or placed in, upon or under such building, including all repairs and replacements of such property.

The Agency will appoint the Company as its only direct agent for the Project. The agency appointment includes the power of the Company to delegate such agency appointment, in whole or in part, to agents, subagents, contractors, subcontractors, materialmen, suppliers and vendors of the Company and to such other parties as the Company chooses so long as they are engaged, directly or indirectly, in the activities hereinbefore described. Please advise the Executive Director of the Agency if you wish to appoint a contractor or other subagent, and the Agency will issue an ST-60 to that party.

In exercising this agency appointment, you and each of your properly appointed agents and subagents must claim the sales tax exemption for all purchases by giving your vendors New York State Form ST-123. The supplier or vendor should identify the Facility on each bill or invoice as the "**Central Utica Building, LLC Facility**" and indicate thereon that the Company, its agents, subagents, contractors and subcontractors acted as agent for the Agency in making the purchase.

You and each of your agents, subagents, contractors and/or subcontractors claiming a sales tax exemption in connection with the Facility must complete a New York State Department of Taxation and Finance Form ST-60. Original copies of each completed Form ST-60 must be delivered to the Agency within five (5) days of the

appointment of each of your agents, subagents, contractors or subcontractors. Any agent, subagent, contractor or subcontractors of the Company which delivers completed Form ST-60 to the Agency will be deemed to be the agent, subagent, contractor or subcontractor of the Agency for purposes of constructing and equipping the Facility, and shall only then be authorized to use Form ST-123 as described above. Failure to comply with these requirements may result in loss of sales tax exemptions for the Facility.

It is important to note that contractors and subcontractors who have not been appointed subagent cannot use the sales tax exemption for equipment rental, tools, supplies and other items that do not become part of the finished project. Contractors and subcontractors must be appointed as agent or sub-agent of the Agency to use the Agency sales tax exemption for these purchases. Contractors and subcontractors who have not been appointed a subagent and are making purchases that would otherwise be exempt outside of the Agency's interest in the Facility must claim the sales tax exemption for construction materials by giving their vendors a completed "Contractor Exempt Purchase Certificate" (Form ST-120.1) checking box (a).

The aforesaid appointment of the Company as agent of the Agency to renovate and equip the Facility shall expire at the earlier of (a) the completion of such activities and improvements, or (b) November 19, 2022, provided, however, such appointment may be extended at the discretion of the Agency, upon the written request of the Company if such activities and improvements are not completed by such time, and further provided that the Agency shall not unreasonably withhold its consent to the extension of such appointment.

Based upon representations made by the Company, the value of the sales tax to be abated relating to the renovation and equipping of the Facility is estimated at estimated at \$1,820,000; the value of sales tax exemptions currently authorized by the Agency is not to exceed \$2,002,000. The Agency is required by law to recapture any New York State sales tax exemptions claimed by the Company that (a) exceed \$100,000 for purchases made between November 19, 2021 and the date of the public hearing; and (b) exceed \$2,002,000 for purchases made relating to the Project in the aggregate.

You should be aware that the New York State General Municipal Law requires you to file an Annual Statement (Form ST-340) with the New York State Department of Taxation and Finance regarding the value of sales tax exemptions you, your agents, consultants or subcontractors have claimed pursuant to the authority we have conferred on you with respect to the Project. We are providing a form of a worksheet for you to track all exempt purchases made in completing the Project, using Forms ST-123 or Form ST-120.1. Please provide the Agency with a copy of Form ST-340 along with your annual report to the Agency and this worksheet. The penalty for failure to file such statement, or to provide a copy to the Agency, is the removal of your authority to act as an agent.

If, for some reason, this transaction never closes, you will be liable for payment of the sales tax, if applicable and you are not otherwise exempt, on all materials purchased.

Please sign and return a copy of this letter for our files. The Agency will issue and deliver Form ST-60 to you upon receipt of this signed agency appointment letter. The Agency reserves the right to issue a revised agency appointment letter with respect to the process for utilizing and reporting exemptions hereunder.

Very truly yours,

ONEIDA COUNTY INDUSTRIAL  
DEVELOPMENT AGENCY

By: \_\_\_\_\_  
Name:  
Title:

ACCEPTED & AGREED:

CENTRAL UTICA BUILDING, LLC

By: \_\_\_\_\_  
Name:  
Title:

**From:** [Dave Quirello](#)  
**To:** [Mark Kaucher](#)  
**Cc:** [Shawna Papale](#)  
**Subject:** RE: Prevailing Wage Rates on IDA Projects  
**Date:** Tuesday, December 21, 2021 10:19:34 AM  
**Attachments:** [image002.png](#)

---

Based on a quick look this is not applicable because "public funds" which include tax breaks do not represent at least 30% of the total construction project costs.

David Quirello, CMPE  
Chief Financial Officer



**Central New York Cardiology**  
2211 Genesee Street  
Utica NY 13501  
Phone: (315) 733-7598 ext. 2236  
Fax: (315) 733-7694  
[dquirello@cnycardiology.com](mailto:dquirello@cnycardiology.com)

**From:** Mark Kaucher [<mailto:mkaucher@mvedge.org>]  
**Sent:** Thursday, December 16, 2021 3:28 PM  
**To:** Dave Quirello <[dquirello@cnycardiology.com](mailto:dquirello@cnycardiology.com)>  
**Cc:** Shawna Papale <[spapale@mvedge.org](mailto:spapale@mvedge.org)>  
**Subject:** Prevailing Wage Rates on IDA Projects

Dear David,

Please see the attached.

Best Regards,

**Mark F. Kaucher, V. P. Economic Development**  
Mohawk Valley EDGE  
584 Phoenix Drive, Rome, NY 13441  
(315) 338-0393/Office (315) 271-7276/cell  
(315) 338-5694/Fax [mkaucher@mvedge.org](mailto:mkaucher@mvedge.org)

CAUTION: This email originated from outside of the organization. Do not click links or open attachments unless you recognize the sender and know the content is safe.



**From:** [Dave Quirello](#)  
**To:** [Mark Kaucher](#)  
**Cc:** [Shawna Papale](#)  
**Subject:** RE: Prevailing Wage Rates on IDA Projects  
**Date:** Friday, December 17, 2021 12:54:24 PM  
**Attachments:** [image002.png](#)

---

This isn't good!

David Quirello, CMPE  
Chief Financial Officer



Central New York Cardiology

2211 Genesee Street

Utica NY 13501

Phone: (315) 733-7598 ext. 2236

Fax: (315) 733-7694

[dquirello@cnycardiology.com](mailto:dquirello@cnycardiology.com)

**From:** Mark Kaucher [<mailto:mkaucher@mvedge.org>]  
**Sent:** Thursday, December 16, 2021 3:28 PM  
**To:** Dave Quirello <[dquirello@cnycardiology.com](mailto:dquirello@cnycardiology.com)>  
**Cc:** Shawna Papale <[spapale@mvedge.org](mailto:spapale@mvedge.org)>  
**Subject:** Prevailing Wage Rates on IDA Projects

Dear David,

Please see the attached.

Best Regards,

**Mark F. Kaucher, V. P. Economic Development**  
Mohawk Valley EDGE  
584 Phoenix Drive, Rome, NY 13441  
(315) 338-0393/Office (315) 271-7276/cell  
(315) 338-5694/Fax [mkaucher@mvedge.org](mailto:mkaucher@mvedge.org)

CAUTION: This email originated from outside of the organization. Do not click links or open attachments unless you recognize the sender and know the content is safe.





Anthony J. Picente Jr.  
County Executive

Shawna M. Papale  
Secretary/Executive Director

Jennifer Waters  
Assistant Secretary

ONEIDA COUNTY INDUSTRIAL  
DEVELOPMENT AGENCY



584 Phoenix Drive,  
Rome, New York 13441-4105  
(315) 338-0393, fax (315) 338-5694  
[info@mvedge.org](mailto:info@mvedge.org), [www.mvedge.org](http://www.mvedge.org)

David C. Grow  
Chairman

Michael Fitzgerald  
Vice Chairperson

Mary Falth Messenger  
Treasurer

Ferris Betrus, Jr.  
Kirk Hinman  
Eugene Quadraro  
Stephen Zogby

December 16, 2021

Central Utica Building, LLC  
Davis Quirello  
2211 Genesee St.  
Utica, NY 13501

Dear David,

Effective for closings that occur after December 31, 2021, certain industrial agency projects will be subject to prevailing wage rules. We had hoped to be able to provide clients with some basic guidance regarding the impending change in law long before now, but as of today the language of the statute is ambiguous at best, and more aptly described as nearly impossible to interpret. New York State has yet to appoint a member to the committee that will have oversight, and who will be able to answer questions regarding terms that have no assigned definition.

Compliance is fully the obligation of the project operator. I am attaching the legislation here so you can review with your counsel to determine what impact, if any, such a rule will have on your project.

We will keep project operators apprised if we receive more definitive guidance on the subject.

If you have any questions, please feel free to contact me at (315) 338-0393.

Sincerely,

Shawna Papale  
Executive Director

Att.

13 Section 1. The labor law is amended by adding a new section 224-a to  
14 read as follows:

15 § 224-a. Prevailing wage requirements applicable to construction  
16 projects performed under private contract. 1. Subject to the provisions  
17 of this section, each "covered project" as defined in this section shall  
18 be subject to prevailing wage requirements in accordance with section  
19 two hundred twenty and two hundred twenty-b of this article. A "covered  
20 project" shall mean construction work done under contract which is paid  
21 for in whole or in part out of public funds as such term is defined in  
22 this section where the amount of all such public funds, when aggregated,  
23 is at least thirty percent of the total construction project costs and  
24 where such project costs are over five million dollars except as  
25 provided for by section two hundred twenty-four-c of this article.

26 2. For purposes of this section, "paid for in whole or in part out of  
27 public funds" shall mean any of the following:

28 a. The payment of money, by a public entity, or a third party acting  
29 on behalf of and for the benefit of a public entity, directly to or on  
30 behalf of the contractor, subcontractor, developer or owner that is not  
31 subject to repayment;

32 b. The savings achieved from fees, rents, interest rates, or other  
33 loan costs, or insurance costs that are lower than market rate costs;  
34 savings from reduced taxes as a result of tax credits, tax abatements,  
35 tax exemptions or tax increment financing; savings from payments in lieu  
36 of taxes; and any other savings from reduced, waived, or forgiven costs  
37 that would have otherwise been at a higher or market rate but for the  
38 involvement of the public entity;

39 c. Money loaned by the public entity that is to be repaid on a contin-  
40 gent basis; or

41 d. Credits that are applied by the public entity against repayment of  
42 obligations to the public entity.

43 3. For purposes of this section, "paid for in whole or in part out of  
44 public funds" shall not include:

45 a. Benefits under section four hundred twenty-one-a of the real prop-  
46 erty tax law;

47 b. Funds that are not provided primarily to promote, incentivize, or  
48 ensure that construction work is performed, which would otherwise be  
49 captured in subdivision two of this section;

50 c. Funds used to incentivize or ensure the development of a comprehen-  
51 sive sewage system, including connection to existing sewer lines or  
52 creation of new sewage lines or sewer capacity, provided, however, that

S. 7508--B

96

A. 9508--B

1 such work shall be deemed to be a public work covered under the  
2 provisions of this article;

3 d. tax benefits provided for projects the length or value of which are  
4 not able to be calculated at the time the work is to be performed;

5 e. tax benefits related to brownfield remediation or brownfield rede-  
6 velopment pursuant to section twenty-one, twenty-two, one hundred eight-  
7 y-seven-g or one hundred eighty-seven-h of the tax law, subdivision  
8 seventeen or eighteen of section two hundred ten-B of the tax law,  
9 subsection (dd) or (ee) of section six hundred six of the tax law, or  
10 subdivision (u) or (v) of section fifteen hundred eleven of the tax law;

11 f. funds provided pursuant to subdivision three of section twenty-  
12 eight hundred fifty-three of the education law; and

13 g. any other public monies, credits, savings or loans, determined by  
14 the public subsidy board created in section two hundred twenty-four-c of  
15 this article as exempt from this definition.

16 4. For purposes of this section "covered project" shall not include  
17 any of the following:

18 a. Construction work on one or two family dwellings where the property  
19 is the owner's primary residence, or construction work performed on

20 property where the owner of the property owns no more than four dwelling  
21 units;

22 b. Construction work performed under a contract with a not-for-profit  
23 corporation as defined in section one hundred two of the not-for-profit  
24 corporation law, other than a not-for-profit corporation formed exclu-  
25 sively for the purpose of holding title to property and collecting  
26 income thereof or any public entity as defined in this section where the  
27 not-for-profit corporation has gross annual revenue and support less  
28 than five million dollars;

29 c. Construction work performed on a multiple residence and/or ancil-  
30 lary amenities or installations that is wholly privately owned in any of  
31 the following circumstances except as provided for by section two  
32 hundred twenty-four-c of this article:

33 (i) where no less than twenty-five percent of the residential units  
34 are affordable and shall be retained subject to an anticipated regula-  
35 tory agreement with a local, state, or federal governmental entity, or a  
36 not-for-profit entity with an anticipated formal agreement with a local,  
37 state, or federal governmental entity for purposes of providing afforda-  
38 ble housing in a given locality or region provided that the period of  
39 affordability for a residential unit deemed affordable under the  
40 provisions of this paragraph shall be for no less than fifteen years  
41 from the date of construction; or

42 (ii) where no less than thirty-five percent of the residential units  
43 involves the provision of supportive housing services for vulnerable  
44 populations provided that such units are subject to an anticipated regu-  
45 latory agreement with a local, state, or federal governmental entity; or

46 (iii) any newly created programs for affordable or subsidized housing  
47 as determined by the public subsidy board established by section two  
48 hundred twenty-four-c of this article.

49 d. Construction work performed on a manufactured home park as defined  
50 in paragraph three of subdivision a of section two hundred thirty-three  
51 of the real property law where the manufactured home park is subject to  
52 a regulatory agreement with a local, state, or federal governmental  
53 entity for no less than fifteen years;

54 e. Construction work performed under a pre-hire collective bargaining  
55 agreement between an owner or contractor and a bona fide building and  
56 construction trade labor organization which has established itself as

S. 7508--B

97

A. 9508--B

1 the collective bargaining representative for all persons who will  
2 perform work on such a project, and which provides that only contractors  
3 and subcontractors who sign a pre-negotiated agreement with the labor  
4 organization can perform work on such a project, or construction work  
5 performed under a labor peace agreement, project labor agreement, or any  
6 other construction work performed under an enforceable agreement between  
7 an owner or contractor and a bona fide building and construction trade  
8 labor organization;

9 f. Construction work performed on projects funded by section sixteen-n  
10 of the urban development corporation act or the downtown revitalization  
11 initiative;

12 g. Construction work and engineering and consulting services performed  
13 in connection with the installation of a renewable energy system, renew-  
14 able heating or cooling system, or energy storage system, with a capaci-  
15 ty equal to or under five megawatts alternating current;

16 h. Construction work performed on supermarket retail space built or  
17 renovated with tax incentives provided under the food retail expansion  
18 to support health (FRESH) program through the New York city industrial  
19 development agency;

20 i. Construction work performed for interior fit-outs and improvements  
21 under ten thousand square feet through small business incubation  
22 programs operated by the New York city economic development corporation;

23 j. Construction work on space to be used as a school under sixty thou-  
24 sand square feet, pursuant to a lease from a private owner to the New

25 York city department of education and the school construction authority;  
26 or

27 k. Construction work performed on projects that received tax benefits  
28 related to historic rehabilitation pursuant to subdivision twenty-six of  
29 section two hundred ten-B of the tax law, subsection (oo) or (pp) of  
30 section six hundred six of the tax law, or subdivision (y) of section  
31 fifteen hundred eleven of the tax law.

32 5. For purposes of this section, "public entity" shall include, but  
33 shall not be limited to, the state, a local development corporation as  
34 defined in subdivision eight of section eighteen hundred one of the  
35 public authorities law or section fourteen hundred eleven of the not-  
36 for-profit corporation law, a municipal corporation as defined in  
37 section one hundred nineteen-n of the general municipal law, an indus-  
38 trial development agency formed pursuant to article eighteen-A of the  
39 general municipal law or industrial development authorities formed  
40 pursuant to article eight of the public authorities law, and any state,  
41 local or interstate or international authorities as defined in section  
42 two of the public authorities law; and shall include any trust created  
43 by any such entities.

44 6. For purposes of this section, "construction" means work which shall  
45 be as defined by the public subsidy board to require payment of prevail-  
46 ing wage, and which may involve the employment of laborers, workers, or  
47 mechanics.

48 7. For purposes of this section and section two hundred twenty-four-b  
49 of this article, the "fiscal officer" shall be deemed to be the commis-  
50 sioner.

51 8. The enforcement of any construction work deemed to be a covered  
52 project pursuant to this section, and any additional requirements, shall  
53 be subject, in addition to this section, only to the requirements of  
54 sections two hundred twenty, two hundred twenty-four-b, two hundred  
55 twenty-four-c, and two hundred twenty-b of this article and within the  
56 jurisdiction of the fiscal officer; provided, however, nothing contained  
S. 7508--B 98 A. 9508--B

1 in this section shall be deemed to construe any covered project as  
2 otherwise being considered public work pursuant to this article; and  
3 further provided:

4 a. The owner or developer of such covered project shall certify under  
5 penalty of perjury within five days of commencement of construction work  
6 whether the project at issue is subject to the provisions of this  
7 section through the use of a standard form developed by the fiscal offi-  
8 cer.

9 b. The owners or developers of a property who are undertaking a  
10 project under private contract, may seek guidance from the public subsi-  
11 dy board contained in section two hundred twenty-four-c of this article,  
12 and such board may render an opinion as to whether or not the project is  
13 a covered project within the meaning of this article. Any such determi-  
14 nation shall not be reviewable by the fiscal officer, nor shall it be  
15 reviewable by the department pursuant to section two hundred twenty of  
16 this article.

17 c. The owner or developer of a covered project shall be responsible  
18 for retaining original payroll records in accordance with section two  
19 hundred twenty of this article for a period of six years from the  
20 conclusion of such work. All payroll records maintained by an owner or  
21 developer pursuant to this section shall be subject to inspection on  
22 request of the fiscal officer. Such owner or developer may authorize  
23 the prime contractor of the construction project to take responsibility  
24 for retaining and maintaining payroll records, but will be held jointly  
25 and severally liable for any violations of such contractor. All records  
26 obtained by the fiscal officer shall be subject to the Freedom of Infor-  
27 mation Law.

28 d. Each public entity providing any of the public funds listed in  
29 subdivision two of this section to an owner, developer, contractor or

30 subcontractor of a project shall identify the nature and dollar value of  
31 such funds and whether any such funds are excluded under subdivision  
32 three of this section and shall so notify the recipient of such funds of  
33 such determination and of their obligations under paragraph a of this  
34 subdivision.

35 e. The fiscal officer may issue rules and regulations governing the  
36 provisions of this section. Violations of this section shall be grounds  
37 for determinations and orders pursuant to section two hundred twenty-b  
38 of this article.

39 9. Each owner and developer subject to the requirements of this  
40 section shall comply with the objectives and goals of minority and  
41 women-owned business enterprises pursuant to article fifteen-A of the  
42 executive law and service-disabled veteran-owned businesses pursuant to  
43 article seventeen-B of the executive law. The department in consulta-  
44 tion with the directors of the division of minority and women's business  
45 development and of the division of service-disabled veterans' business  
46 development shall make training and resources available to assist minor-  
47 ity and women-owned business enterprises and service-disabled veteran-  
48 owned business enterprises on covered projects achieve and maintain  
49 compliance with prevailing wage requirements. The department shall make  
50 such training and resources available online and shall afford minority  
51 and women-owned business enterprises and service-disabled veteran-owned  
52 business enterprises an opportunity to submit comments on such training.

53 10. a. The fiscal officer shall report to the governor, the temporary  
54 president of the senate, and the speaker of the assembly by July first,  
55 two thousand twenty-two, and annually thereafter, on the participation  
56 of minority and women-owned business enterprises in relation to covered

S. 7508--B

99

A. 9508--B

1 projects and contracts for public work subject to the provisions of this  
2 section and section two hundred twenty of this article respectively as  
3 well as the diversity practices of contractors and subcontractors  
4 employing laborers, workers, and mechanics on such projects.

5 b. Such reports shall include aggregated data on the utilization and  
6 participation of minority and women-owned business enterprises, the  
7 employment of minorities and women in construction-related jobs on such  
8 projects, and the commitment of contractors and subcontractors on such  
9 projects to adopting practices and policies that promote diversity with-  
10 in the workforce. The reports shall also examine the compliance of  
11 contractors and subcontractors with other equal employment opportunity  
12 requirements and anti-discrimination laws, in addition to any other  
13 employment practices deemed pertinent by the commissioner.

14 c. The fiscal officer may require any owner or developer to disclose  
15 information on the participation of minority and women-owned business  
16 enterprises and the diversity practices of contractors and subcontractors  
17 involved in the performance of any covered project. It shall be  
18 the duty of the fiscal officer to consult and to share such information  
19 in order to effectuate the requirements of this section.

20 11. If construction work is not deemed to be a covered project, wheth-  
21 er by virtue of an exclusion of such project under subdivision four of  
22 this section, or by virtue or not receiving sufficient public money to  
23 be deemed "paid for in whole or in part out of public funds", such  
24 project shall not be subject to the requirements of sections two hundred  
25 twenty and two hundred twenty-b of this article.

26 § 2. The labor law is amended by adding a new section 224-b to read as  
27 follows:

28 § 224-b. Stop-work orders. Where a complaint is received pursuant to  
29 this article, or where the fiscal officer upon his or her own investi-  
30 gation, finds cause to believe that any person, in connection with the  
31 performance of any contract for public work pursuant to section two  
32 hundred twenty of this article or any covered project pursuant to  
33 section two hundred twenty-four-a of this article, has substantially and  
34 materially failed to comply with or intentionally evaded the provisions

35 of this article, the fiscal officer may notify such person in writing of  
36 his or her intention to issue a stop-work order. Such notice shall (i)  
37 be served in a manner consistent with section three hundred eight of the  
38 civil practice law and rules; (ii) notify such person of his or her  
39 right to a hearing; and (iii) state the factual basis upon which the  
40 fiscal officer has based his or her decision to issue a stop-work order.  
41 Any documents, reports, or information that form a basis for such deci-  
42 sion shall be provided to such person within a reasonable time before  
43 the hearing. Such hearing shall be expeditiously conducted.

44 Following the hearing, if the fiscal officer issues a stop-work order,  
45 it shall be served by regular mail, and a second copy may be served by  
46 telefacsimile or by electronic mail, with service effective upon receipt  
47 of any such order. Such stop-work order shall also be served with regard  
48 to a worksite by posting a copy of such order in a conspicuous location  
49 at the worksite. The order shall remain in effect until the fiscal offi-  
50 cer directs that the stop-work order be removed, upon a final determi-  
51 nation on the complaint or where such failure to comply or evade has  
52 been deemed corrected. If the person against whom such order is issued  
53 shall within thirty days after issuance of the stop-work order makes an  
54 application in affidavit form for a redetermination review of such order  
55 the fiscal officer shall make a decision in writing on the issues raised  
56 in such application. The fiscal officer may direct a conditional release  
S. 7508--B 100 A. 9508--B

1 from a stop-work order upon a finding that such person has taken mean-  
2 ingful and good faith steps to comply with the provisions of this arti-  
3 cle.

4 § 3. The labor law is amended by adding a new section 224-c to read as  
5 follows:

6 § 224-c. Public subsidy board. 1. A board on public subsidies, herein-  
7 after "the board", is hereby created, to consist of thirteen members.  
8 The thirteen members shall be appointed by the governor as follows: one  
9 member upon the recommendation of the temporary president of the senate,  
10 one member upon the recommendation of the speaker of the assembly, the  
11 commissioner, the president of the empire state development corporation,  
12 the director of the division of the budget, two members representing  
13 employees in the construction industry, of whom one shall be a represen-  
14 tative of the largest statewide trade labor association representing  
15 building and construction workers, and one shall be a representative of  
16 the largest trade labor association representing building and  
17 construction workers with membership in New York City, and two members  
18 representing employers in the construction industry, of whom one shall  
19 be a representative of the largest statewide organization representing  
20 building owners and developers, either for-profit or not-for-profit, and  
21 one shall be a representative of a statewide organization representing  
22 building owners and developers, either for-profit or not-for-profit,  
23 representing a region different than the region primarily represented by  
24 the initial employer representative. The commissioner shall act as the  
25 chair. The members shall serve at the pleasure of the authority recom-  
26 mending, designating, or otherwise appointing such member and shall  
27 serve without salary or compensation but shall be reimbursed for neces-  
28 sary expenses incurred in the performance of their duties.

29 2. The board shall meet on an as needed basis and shall have the power  
30 to conduct public hearings. The board may also consult with employers  
31 and employees, and their respective representatives, in the construction  
32 industry and with such other persons, including the commissioner, as it  
33 shall determine. No public officer or employee appointed to the board  
34 shall forfeit any position or office by virtue of appointment to such  
35 board. Any proceedings of the board which relate to a particular indi-  
36 vidual or project shall be confidential.

37 3. The board may examine and make recommendations regarding the  
38 following:

39 (a) the minimum threshold percentage of public funds set forth in

40 subdivision one of section two hundred twenty-four-a of this article,  
41 but no lower than that which is set forth in such subdivision;

42 (b) the minimum dollar threshold of projects set forth in subdivision  
43 one of section two hundred twenty-four-a of this article, but no lower  
44 than that which is set forth in such subdivision;

45 (c) construction work excluded as a covered project, as set forth in  
46 subparagraphs (i), (ii) and (iii) of paragraph c of subdivision four of  
47 section two hundred twenty-four-a of this article;

48 (d) the definition of construction for purposes of section two hundred  
49 twenty-four-a of this article; or

50 (e) particular instances of benefits, monies or credits as to whether  
51 or not they should constitute public funds.

52 4. Prior to making any recommendation intended to apply to all  
53 projects, the board shall hold a public hearing. The board shall  
54 announce each public hearing at least fifteen days in advance. The  
55 announcement shall contain an agenda of the topics the board will  
56 discuss. At each hearing, the board may hear testimony and/or review

S. 7508--B

101

A. 9508--B

1 written documents from any interested stakeholders related to the  
2 planned agenda of the meeting. The board shall make any such recommen-  
3 dations in writing. In making its recommendations, the board shall exam-  
4 ine the impact of such thresholds and circumstances on private develop-  
5 ment in light of available public subsidies, existing labor market  
6 conditions, prevailing wage and supplement practices, and shall consider  
7 the extent to which adjustments to such thresholds and circumstances  
8 could ameliorate adverse impacts, if any, or expand opportunities for  
9 prevailing wage and supplement standards on publicly subsidized private  
10 construction projects in any region or regions of the state.

11 5. The board shall be empowered to issue binding determinations to any  
12 public entity, or any private or not-for-profit owner or developer as to  
13 any particular matter related to an existing or potential covered  
14 project. In such instances the board shall make a determination based  
15 upon documents, or testimony, or both in its sole discretion. Any such  
16 proceedings shall be confidential, except that publication of such deci-  
17 sions shall be made available on the department's website, subject to  
18 redaction or confidentiality as the board shall deem warranted in  
19 accordance with any applicable federal or state statutory or regulatory  
20 requirement governing confidentiality and personal privacy.

21 6. Any recommendation rendered by the board pursuant to this section  
22 shall be subject to the provisions of article seventy-eight of the civil  
23 practice law and rules.

24 7. In the event that the board finds that there is or likely would be  
25 a significant negative economic impact of implementing the prevailing  
26 wage requirements provided for in section two hundred twenty-four-a of  
27 this article, the board may temporarily delay the implementation of such  
28 requirements beyond January first, two thousand twenty-two. Such a delay  
29 may be effective statewide or effective only in a region of the state as  
30 defined by the regional economic development councils. In making such a  
31 determination to delay, the board shall consult the department, the  
32 department's division of research and statistics, the United States  
33 department of labor, the federal reserve bank of New York and other  
34 economic experts. The board will reference well-established economic  
35 indexes and accepted economic factors tied to the construction industry,  
36 including but not limited to construction industry employment, wages,  
37 and overall construction activity.

38 § 4. The labor law is amended by adding a new section 813-a to read as  
39 follows:

40 § 813-a. Annual reports by apprenticeship programs. 1. On an annual  
41 basis, all apprenticeship programs covered under the provisions of this  
42 article shall report to the department on the participation of appren-  
43 tices currently enrolled in such apprenticeship program. The data to be  
44 included in such report shall include, at a minimum: (a) the total



45 number of apprentices in such apprenticeship program; (b) the demograph-  
46 ic information of such apprentices to the extent such data is available,  
47 including, but not limited to, the age, gender, race, ethnicity, and  
48 national origin of such apprentices; (c) the rate of advancement and  
49 graduation of such apprentices; and (d) the rate of placement of such  
50 apprentices onto job sites as well as the demographic information of  
51 such apprentices to the extent such data is available, including, but  
52 not limited to the age, gender, race, ethnicity, and national origin of  
53 such apprentices.

54 2. The department shall make such data publicly available on its  
55 website by July first, two thousand twenty-two and on an annual basis,  
56 but no later than December thirty-first of each following year.

S. 7508--B

102

A. 9508--B

1 3. The commissioner may promulgate rules and regulations necessary for  
2 the implementation of this section.

3 § 5. Severability clause. If any clause, sentence, paragraph, subdivi-  
4 sion, or section of this act shall be adjudged by any court of competent  
5 jurisdiction to be invalid, such judgment shall not affect, impair, or  
6 invalidate the remainder thereof, but shall be confined in its operation  
7 to the clause, sentence, paragraph, subdivision, or section thereof  
8 directly involved in the controversy in which such judgment shall have  
9 been rendered. It is hereby declared to be the intent of the legislature  
10 that this act would have been enacted even if such invalid provisions  
11 had not been included herein.

12 § 6. This act shall take effect on January 1, 2022 and shall apply to  
13 contracts for construction executed, incentive agreements executed,  
14 procurements or solicitations issued, or applications for building  
15 permits on or after such date; provided however that section three of  
16 this act shall take effect on April 1, 2021, and provided further that  
17 this act shall not pre-exempt any existing contracts, nor apply to any  
18 appropriations of public funds made prior to the day on which this act  
19 shall have become a law, or to re-appropriations of such funds first  
20 appropriated prior to the day on which this act shall have become a law.  
21 Effective immediately, the addition, amendment and/or repeal of any rule  
22 or regulation necessary for the implementation of this act on its effec-  
23 tive date are authorized to be made and completed on or before such  
24 effective date.

**From:** Dave Quirello  
**To:** Shawna Papale  
**Cc:** Bruce A. Smith; michaelkeiberman@roadrunner.com; Ruberto, Laura; Linda Romano  
**Subject:** Re: Sales Tax Exemption  
**Date:** Thursday, December 30, 2021 5:45:22 PM

---

That's what I thought. Thank you.

Dave  
sent from my iPhone

On Dec 30, 2021, at 5:37 PM, Shawna Papale <spapale@mvedge.org> wrote:

Dave I would do it when you come close to the \$1.8 million. Shawna

Shawna Papale  
Sent from my iPhone

On Dec 30, 2021, at 2:05 PM, Dave Quirello  
<dquirello@cnycardiology.com> wrote:

Shawna,

I need some clarity. I know we were approved for up to \$2MM and thank you. However, are we to reapply with an increased budget now or come close to maximizing the \$1.8MM and then ask for more?

David Quirello, CMPE  
Chief Financial Officer  
<image001.png>

2211 Genesee Street  
Utica NY 13501  
Phone: (315) 733-7598 ext. 2236  
Fax: (315) 733-7694  
dquirello@cnycardiology.com

CAUTION: This email originated from outside of the organization.  
Do not click links or open attachments unless you recognize the sender and know the content is safe.

CAUTION: This email originated from outside of the organization. Do not click links or open attachments unless you recognize the sender and know the content is safe.

**From:** [Dave Quirello](#)  
**To:** [Ruberto, Laura](#); ["Bruce A. Smith"](#); [Mark Kaucher](#); [Shawna Papale](#)  
**Cc:** ["Romano, Linda"](#)  
**Subject:** RE: Central Utica Building, LLC/Oneida County IDA  
**Date:** Monday, January 3, 2022 3:41:49 PM  
**Attachments:** [image004.png](#)  
[image001.png](#)

---

I will be out of town from Jan 8-22

David Quirello, CMPE  
Chief Financial Officer



Central New York Cardiology

2211 Genesee Street  
Utica NY 13501  
Phone: (315) 733-7598 ext. 2236  
Fax: (315) 733-7694  
[dquirello@cnycardiology.com](mailto:dquirello@cnycardiology.com)

**From:** Ruberto, Laura [<mailto:RubertL@bsk.com>]  
**Sent:** Monday, January 3, 2022 3:00 PM  
**To:** Dave Quirello <[dquirello@cnycardiology.com](mailto:dquirello@cnycardiology.com)>; 'Bruce A. Smith' <[bsmith@ccblaw.com](mailto:bsmith@ccblaw.com)>; 'Mark Kaucher' <[mkaucher@mvedge.org](mailto:mkaucher@mvedge.org)>; 'Shawna Papale' <[spapale@mvedge.org](mailto:spapale@mvedge.org)>  
**Cc:** Romano, Linda <[romanol@bsk.com](mailto:romanol@bsk.com)>  
**Subject:** RE: Central Utica Building, LLC/Oneida County IDA

No problem, our email came at the same time as your conversation about the increase so the confusion is understandable. I believe the proposed dates for the hearing are now January 19 or 20 – do you have a preference?

**Laura S. Ruberto**  
315.738.1223 Direct

**From:** Dave Quirello <[dquirello@cnycardiology.com](mailto:dquirello@cnycardiology.com)>  
**Sent:** Monday, January 03, 2022 2:55 PM  
**To:** Ruberto, Laura <[RubertL@bsk.com](mailto:RubertL@bsk.com)>; 'Bruce A. Smith' <[bsmith@ccblaw.com](mailto:bsmith@ccblaw.com)>; 'Mark Kaucher' <[mkaucher@mvedge.org](mailto:mkaucher@mvedge.org)>; 'Shawna Papale' <[spapale@mvedge.org](mailto:spapale@mvedge.org)>  
**Cc:** Romano, Linda <[romanol@bsk.com](mailto:romanol@bsk.com)>  
**Subject:** RE: Central Utica Building, LLC/Oneida County IDA

**External Email:** Use caution before clicking links or opening attachments.

Ok Laura that makes sense. Sorry I was confused thinking you were talking about the jump to \$2MM. The 25<sup>th</sup> and 27<sup>th</sup> would work best.

David Quirello, CMPE

Chief Financial Officer



Central New York Cardiology

2211 Genesee Street

Utica NY 13501

Phone: (315) 733-7598 ext. 2236

Fax: (315) 733-7694

[dquirello@cnycardiology.com](mailto:dquirello@cnycardiology.com)

**From:** Ruberto, Laura [<mailto:Ruberti@bsk.com>]

**Sent:** Monday, January 3, 2022 12:52 PM

**To:** Dave Quirello <[dquirello@cnycardiology.com](mailto:dquirello@cnycardiology.com)>; 'Bruce A. Smith' <[bsmith@ccblaw.com](mailto:bsmith@ccblaw.com)>; 'Mark Kaucher' <[mkaucher@mvedge.org](mailto:mkaucher@mvedge.org)>; 'Shawna Papale' <[spapale@mvedge.org](mailto:spapale@mvedge.org)>

**Cc:** Romano, Linda <[romanol@bsk.com](mailto:romanol@bsk.com)>

**Subject:** RE: Central Utica Building, LLC/Oneida County IDA

Dave, at the December meeting the IDA amended its inducement to omit the \$500,000 limit on the sales tax exemption. This amendment only amounts to preliminary approval of the \$1.8 million sales tax exemption. Before it can consider final approval, the IDA must conduct a public hearing relating to this proposed amendment to financial assistance. Following the public hearing, the IDA will consider a final authorizing resolution which, if adopted, will grant the final approvals for the \$1.8 million sales tax. The IDA would like to consider the final resolution at its January 21 meeting, which is why they would like to conduct the hearing earlier that week.

I believe the conversation relating to the additional funding is a request to increase the value above \$1.8 million, which would come at a later date.

I hope this is helpful.

**Laura S. Ruberto**

315.738.1223 Direct

**From:** Dave Quirello <[dquirello@cnycardiology.com](mailto:dquirello@cnycardiology.com)>

**Sent:** Monday, January 03, 2022 12:31 PM

**To:** 'Bruce A. Smith' <[bsmith@ccblaw.com](mailto:bsmith@ccblaw.com)>; 'Mark Kaucher' <[mkaucher@mvedge.org](mailto:mkaucher@mvedge.org)>; Ruberto, Laura <[Ruberti@bsk.com](mailto:Ruberti@bsk.com)>; 'Shawna Papale' <[spapale@mvedge.org](mailto:spapale@mvedge.org)>

**Cc:** Romano, Linda <[romanol@bsk.com](mailto:romanol@bsk.com)>

**Subject:** RE: Central Utica Building, LLC/Oneida County IDA

**External Email:** Use caution before clicking links or opening attachments.

Per Shawna's request we are waiting until we get close to using the \$1.8MM before resubmitting for the additional funding?

David Quirello, CMPE

Chief Financial Officer



Central New York Cardiology

2211 Genesee Street

Utica NY 13501

Phone: (315) 733-7598 ext. 2236

Fax: (315) 733-7694

[dquirello@cnycardiology.com](mailto:dquirello@cnycardiology.com)

**From:** Bruce A. Smith [<mailto:bsmith@ccblaw.com>]

**Sent:** Monday, January 3, 2022 11:27 AM

**To:** 'Mark Kaucher' <[mkaucher@mvedge.org](mailto:mkaucher@mvedge.org)>; Ruberto, Laura <[rubertl@bsk.com](mailto:rubertl@bsk.com)>; Dave Quirello <[dquirello@cnycardiology.com](mailto:dquirello@cnycardiology.com)>; Shawna Papale <[spapale@mvedge.org](mailto:spapale@mvedge.org)>

**Cc:** Romano, Linda <[romanol@bsk.com](mailto:romanol@bsk.com)>; David Quirello ([dquirello@cnycardiology.com](mailto:dquirello@cnycardiology.com)) <[dquirello@cnycardiology.com](mailto:dquirello@cnycardiology.com)>

**Subject:** RE: Central Utica Building, LLC/Oneida County IDA

Any day except Friday, January 28

Bruce A. Smith, Esq.

Cohen Compagni Beckman Appler & Knoll, PLLC

507 Plum Street, Suite 310

Syracuse, New York 13204

Direct Phone: (315) 477-6291

Direct Fax: (315) 425-3691

E-mail: [bsmith@ccblaw.com](mailto:bsmith@ccblaw.com)

Website: [www.ccblaw.com](http://www.ccblaw.com)

**This electronic transmission contains information from the law firm of Cohen Compagni Beckman Appler & Knoll, PLLC, which is confidential, covered by the attorney-client privilege, and solely for the person or entity named above. If you are not the intended recipient, be aware that any disclosure, copying, distribution or use of this information is prohibited. If you have received this electronic mail transmission in error, please notify us by telephone, mail or electronic mail and destroy this communication.**

**From:** Mark Kaucher <[mkaucher@mvedge.org](mailto:mkaucher@mvedge.org)>

**Sent:** Monday, January 3, 2022 11:19 AM

**To:** Ruberto, Laura <[rubertl@bsk.com](mailto:rubertl@bsk.com)>; Dave Quirello <[dquirello@cnycardiology.com](mailto:dquirello@cnycardiology.com)>; Shawna Papale <[spapale@mvedge.org](mailto:spapale@mvedge.org)>; Bruce A. Smith <[bsmith@ccblaw.com](mailto:bsmith@ccblaw.com)>

**Cc:** Romano, Linda <[romanol@bsk.com](mailto:romanol@bsk.com)>

**Subject:** RE: Central Utica Building, LLC/Oneida County IDA

How does 10 AM, any day during the week of January the 24<sup>th</sup>, except Wednesday, look?

**Mark F. Kaucher, V. P. Economic Development**

Mohawk Valley EDGE

584 Phoenix Drive, Rome, NY 13441

(315) 338-0393/Office (315) 271-7276/cell

(315) 338-5694/Fax [mkaucher@mvedge.org](mailto:mkaucher@mvedge.org)

**From:** Ruberto, Laura <[RubertL@bsk.com](mailto:RubertL@bsk.com)>

**Sent:** Monday, January 3, 2022 9:04 AM

**To:** Dave Quirello <[dquirello@cnycardiology.com](mailto:dquirello@cnycardiology.com)>; Shawna Papale <[spapale@mvedge.org](mailto:spapale@mvedge.org)>; Mark Kaucher <[mkaucher@mvedge.org](mailto:mkaucher@mvedge.org)>; Bruce A. Smith <[bsmith@ccbllaw.com](mailto:bsmith@ccbllaw.com)>

**Cc:** Romano, Linda <[romanol@bsk.com](mailto:romanol@bsk.com)>

**Subject:** Central Utica Building, LLC/Oneida County IDA

Good morning; the IDA must conduct a public hearing relating to the proposed amended financial assistance. Attached is a legal notice for that purpose – a clean version and a redline version compared against the original legal notice is attached for review.

If we can publish by noon tomorrow, the hearing can be conducted any time after Monday, January 17<sup>th</sup>. Mark/Shawna, would you like to suggest some dates convenient to the IDA?

Best,  
Laura

**Laura S. Ruberto**

Paralegal

Business

315.738.1223 Direct

315.724.2074 Fax

[lruberto@bsk.com](mailto:lruberto@bsk.com)

501 Main Street, Utica, NY 13501-1245

This email is ONLY for the person(s) named in the message header. Unless otherwise indicated, it contains information that is confidential, privileged or exempt from disclosure under applicable law. If you have received it in error, please notify the sender of the error and delete the message.

IRS regulations require us to notify you that any tax advice contained in this communication (including any attachments) is not intended or written to be used, and cannot be used, for the purpose of avoiding penalties under the Internal Revenue Code. If you want a further description of this requirement, go to <https://www.bsk.com/disclaimer>.

**CAUTION:** This email originated from outside of the organization. Do not click links or open attachments unless you recognize the sender and know the content is safe.

**CAUTION:** This email originated from outside of the organization. Do not click links or open attachments unless you recognize the sender and know the content is safe.

**From:** Bruce A. Smith  
**To:** Ruberto, Laura; Dave Quirello; Shawna Papale; Mark Kaucher  
**Cc:** Romano, Linda; David Quirello (dquirello@cnycardiology.com)  
**Subject:** RE: Central Utica Building, LLC/Oneida County IDA  
**Date:** Monday, January 3, 2022 11:25:39 AM

---

Only comment is that the building size is now approx. 94,000 sf

Bruce A. Smith, Esq.  
Cohen Compagni Beckman Appler & Knoll, PLLC  
507 Plum Street, Suite 310  
Syracuse, New York 13204  
Direct Phone: (315) 477-6291  
Direct Fax: (315) 425-3691  
E-mail: [bsmith@ccblaw.com](mailto:bsmith@ccblaw.com)  
Website: [www.ccblaw.com](http://www.ccblaw.com)

**This electronic transmission contains information from the law firm of Cohen Compagni Beckman Appler & Knoll, PLLC, which is confidential, covered by the attorney-client privilege, and solely for the person or entity named above. If you are not the intended recipient, be aware that any disclosure, copying, distribution or use of this information is prohibited. If you have received this electronic mail transmission in error, please notify us by telephone, mail or electronic mail and destroy this communication.**

**From:** Ruberto, Laura <RubertL@bsk.com>  
**Sent:** Monday, January 3, 2022 9:04 AM  
**To:** Dave Quirello <dquirello@cnycardiology.com>; Shawna Papale <spapale@mvedge.org>; Mark Kaucher <mkaucher@mvedge.org>; Bruce A. Smith <bsmith@ccblaw.com>  
**Cc:** Romano, Linda <romanol@bsk.com>  
**Subject:** Central Utica Building, LLC/Oneida County IDA

Good morning; the IDA must conduct a public hearing relating to the proposed amended financial assistance. Attached is a legal notice for that purpose – a clean version and a redline version compared against the original legal notice is attached for review.

If we can publish by noon tomorrow, the hearing can be conducted any time after Monday, January 17<sup>th</sup>. Mark/Shawna, would you like to suggest some dates convenient to the IDA?

Best,  
Laura

**Laura S. Ruberto**  
Paralegal  
Business  
315.738.1223 Direct  
315.724.2074 Fax  
[lruberto@bsk.com](mailto:lruberto@bsk.com)

---

501 Main Street, Utica, NY 13501-1245

This email is ONLY for the person(s) named in the message header. Unless otherwise indicated, it contains information that is confidential, privileged or exempt from disclosure under applicable law. If you have received it in error, please notify the sender of the error and delete the message. IRS regulations require us to notify you that any tax advice contained in this communication (including any attachments) is not intended or written to be used, and cannot be used, for the purpose of avoiding penalties under the Internal Revenue Code. If you want a further description of this requirement, go to <https://www.irs.com/disclaimer>.

**CAUTION: This email originated from outside of the organization. Do not click links or open attachments unless you recognize the sender and know the content is safe.**



## NOTICE OF PUBLIC HEARING

NOTICE IS HEREBY GIVEN that a public hearing pursuant to Article 18-A of the New York State General Municipal Law, will be held by the Oneida County Industrial Development Agency (the "Agency") on the ~~10th~~ \_\_\_\_\_ day of ~~December 2021~~ ~~at 10:00~~ January 2022 at \_\_\_\_\_ a.m., local time, at Oneida County Legislative Chambers, 10<sup>th</sup> Floor, Oneida County Office Building, 800 Park Avenue, Utica, New York in connection with the following matters:

Central Utica Building, LLC, on behalf of itself and/or the principals of Central Utica Building, LLC, and/or an entity formed or to be formed on behalf of any of the foregoing (collectively, the "Company") has applied to the Oneida County Industrial Development Agency (the "Agency") to enter into a transaction in which the Agency will assist in the construction of an 80,000± square foot state-of-the-art medical office building and appurtenant facilities including parking areas and all infrastructure, utilities and amenities to support the same (collectively, the "Improvements") situated on parcels of land measuring 2.90± acres in the aggregate adjacent to the new Wynn Hospital (the "Wynn Hospital") located at the Corner of State and Columbia Streets, City of Utica, Oneida County, New York (the "Land") and acquisition and installation of equipment in the Improvements (the "Equipment"), all for the purpose of providing a seamless and integrated health care delivery system together with the Wynn Hospital, and to enhance and expand the delivery of health care services to the community (the Land, the Improvements and the Equipment are referred to collectively as the "Facility" and the construction and equipping of the Improvements is referred to as the "Project"). The Facility will be initially operated and/or managed by the Company.

The Company will lease the Facility to the Agency, and the Agency will lease the Facility back to the Company pursuant to a leaseback agreement. At the end of the lease term, the Agency will terminate its leasehold interest in the Facility. The Company will sublease a 20,000± square foot portion of the Facility to Central New York Cardiology, P.C. (the "CNYC Sublessee") for its operation for the purpose of performing interventional cardiology services at the Wynn Hospital, to take cardiology call and provide cardiology services to patients admitted to the Wynn Hospital. The Company will sublease an 18,000± square foot portion of the Facility to Mohawk Valley ASC, LLC (the "MVASC Sublessee") for its operation for the purpose of operating an Article 28 licensed, Medicare certified multi-specialty ambulatory surgery center with six operating rooms. The Company will sublease other portions of the Facility to MVHS and other medical practices whose physicians practice in, and need access to, the Wynn Hospital, and to other commercial and/or retail tenants to provide complementary services (such sublessees, together with the CNYC Sublessee and the MVASC Sublessee, are referred to collectively as the "Sublessees").

The Agency is contemplating providing financial assistance in the form of exemptions from mortgage recording taxes and exemptions from sales tax on materials and equipment acquired and installed in connection with the Project, ~~such sales tax exemptions to be limited to \$500,000.00,~~ which financial assistance is a deviation from

consistent with the Agency's Uniform Tax Exemption Policy, to be more particularly described in a Final Authorizing Resolution to be adopted by the Agency prior to the closing of the transactions described herein. Such financial assistance will be conditioned upon the Company creating, retaining and maintaining (or causing the Sublessees to create, retain and maintain) certain employment at the Facility as a result of undertaking the Project.

A representative of the Agency will at the above-stated time and place hear and accept written comments from all persons with views in favor of or opposed to either the proposed financial assistance to the Company or the location or nature of the Facility. Comments may also be submitted to the Agency in writing or electronically prior to the Public Hearing. Members of the public may also ~~access the Public Hearing and comment on the Project and the benefits to be granted to the Applicant by the Agency during listen~~ to the Public Hearing by calling 1-408-418-9388 (Access code: 263 377 79443). Minutes of the Public Hearing will be transcribed and posted on the Agency's website. A copy of the Application for Financial Assistance filed by the Company with the Agency, including an analysis of the costs and benefits of the proposed Project, is available for public inspection at the offices of the Agency, 584 Phoenix Drive, Rome, New York.

ONEIDA COUNTY INDUSTRIAL  
DEVELOPMENT AGENCY

Dated: ~~November 22, 2021~~ January 3, 2022  
Executive Director

By: /s/ Shawna M. Papale,

## NOTICE OF PUBLIC HEARING

NOTICE IS HEREBY GIVEN that a public hearing pursuant to Article 18-A of the New York State General Municipal Law, will be held by the Oneida County Industrial Development Agency (the "Agency") on the \_\_\_\_\_ day of January 2022 at \_\_\_\_\_ a.m., local time, at Oneida County Legislative Chambers, 10<sup>th</sup> Floor, Oneida County Office Building, 800 Park Avenue, Utica, New York in connection with the following matters:

Central Utica Building, LLC, on behalf of itself and/or the principals of Central Utica Building, LLC, and/or an entity formed or to be formed on behalf of any of the foregoing (collectively, the "Company") has applied to the Oneida County Industrial Development Agency (the "Agency") to enter into a transaction in which the Agency will assist in the construction of an 80,000± square foot state-of-the-art medical office building and appurtenant facilities including parking areas and all infrastructure, utilities and amenities to support the same (collectively, the "Improvements") situated on parcels of land measuring 2.90± acres in the aggregate adjacent to the new Wynn Hospital (the "Wynn Hospital") located at the Corner of State and Columbia Streets, City of Utica, Oneida County, New York (the "Land") and acquisition and installation of equipment in the Improvements (the "Equipment"), all for the purpose of providing a seamless and integrated health care delivery system together with the Wynn Hospital, and to enhance and expand the delivery of health care services to the community (the Land, the Improvements and the Equipment are referred to collectively as the "Facility" and the construction and equipping of the Improvements is referred to as the "Project"). The Facility will be initially operated and/or managed by the Company.

The Company will lease the Facility to the Agency, and the Agency will lease the Facility back to the Company pursuant to a leaseback agreement. At the end of the lease term, the Agency will terminate its leasehold interest in the Facility. The Company will sublease a 20,000± square foot portion of the Facility to Central New York Cardiology, P.C. (the "CNYC Sublessee") for its operation for the purpose of performing interventional cardiology services at the Wynn Hospital, to take cardiology call and provide cardiology services to patients admitted to the Wynn Hospital. The Company will sublease an 18,000± square foot portion of the Facility to Mohawk Valley ASC, LLC (the "MVASC Sublessee") for its operation for the purpose of operating an Article 28 licensed, Medicare certified multi-specialty ambulatory surgery center with six operating rooms. The Company will sublease other portions of the Facility to MVHS and other medical practices whose physicians practice in, and need access to, the Wynn Hospital, and to other commercial and/or retail tenants to provide complementary services (such sublessees, together with the CNYC Sublessee and the MVASC Sublessee, are referred to collectively as the "Sublessees").

The Agency is contemplating providing financial assistance in the form of exemptions from mortgage recording taxes and exemptions from sales tax on materials and equipment acquired and installed in connection with the Project, which financial assistance is consistent with the Agency's Uniform Tax Exemption Policy, to be more particularly described in a Final Authorizing Resolution to be adopted by the Agency prior

to the closing of the transactions described herein. Such financial assistance will be conditioned upon the Company creating, retaining and maintaining (or causing the Sublessees to create, retain and maintain) certain employment at the Facility as a result of undertaking the Project.

A representative of the Agency will at the above-stated time and place hear and accept written comments from all persons with views in favor of or opposed to either the proposed financial assistance to the Company or the location or nature of the Facility. Comments may also be submitted to the Agency in writing or electronically prior to the Public Hearing. Members of the public may also listen to the Public Hearing by calling 1-408-418-9388 (Access code: 263 377 79443). Minutes of the Public Hearing will be transcribed and posted on the Agency's website. A copy of the Application for Financial Assistance filed by the Company with the Agency, including an analysis of the costs and benefits of the proposed Project, is available for public inspection at the offices of the Agency, 584 Phoenix Drive, Rome, New York.

ONEIDA COUNTY INDUSTRIAL  
DEVELOPMENT AGENCY

Dated: January 3, 2022

By: /s/ Shawna M. Papale, Executive Director

**From:** [Bruce A. Smith](#)  
**To:** [Ruberto, Laura](#); [Dave Quirello](#); [Shawna Papale](#); [Mark Kaucher](#)  
**Cc:** [Romano, Linda](#)  
**Subject:** RE: Central Utica Building, LLC/Oneida County IDA  
**Date:** Tuesday, January 4, 2022 10:57:42 AM

---

Looks good and I am available to attend

Bruce A. Smith, Esq.  
Cohen Compagni Beckman Appler & Knoll, PLLC  
507 Plum Street, Suite 310  
Syracuse, New York 13204  
Direct Phone: (315) 477-6291  
Direct Fax: (315) 425-3691  
E-mail: [bsmith@ccblaw.com](mailto:bsmith@ccblaw.com)  
Website: [www.ccblaw.com](http://www.ccblaw.com)

**This electronic transmission contains information from the law firm of Cohen Compagni Beckman Appler & Knoll, PLLC, which is confidential, covered by the attorney-client privilege, and solely for the person or entity named above. If you are not the intended recipient, be aware that any disclosure, copying, distribution or use of this information is prohibited. If you have received this electronic mail transmission in error, please notify us by telephone, mail or electronic mail and destroy this communication.**

**From:** Ruberto, Laura <[RubertL@bsk.com](mailto:RubertL@bsk.com)>  
**Sent:** Tuesday, January 4, 2022 10:48 AM  
**To:** Bruce A. Smith <[bsmith@ccblaw.com](mailto:bsmith@ccblaw.com)>; Dave Quirello <[dquirello@cnycardiology.com](mailto:dquirello@cnycardiology.com)>; Shawna Papale <[spapale@mvedge.org](mailto:spapale@mvedge.org)>; Mark Kaucher <[mkaucher@mvedge.org](mailto:mkaucher@mvedge.org)>  
**Cc:** Romano, Linda <[romanol@bsk.com](mailto:romanol@bsk.com)>  
**Subject:** RE: Central Utica Building, LLC/Oneida County IDA

Good morning – attached is a revised legal notice, incorporating Bruce's revision below and clarifying the history of the action taken by the IDA.

The IDA would like to conduct the public hearing prior to the January 21 meeting, despite the fact that Dave will not be available. **Bruce**, will you be able to participate in the hearing in his stead?

If we submit today we do have time to meet notice requirements and conduct the hearing the week of January 17. Please let us know when a date is confirmed and we will finalize the notice for publication.

Thank you,  
Laura

**Laura S. Ruberto**  
315.738.1223 Direct

**From:** Bruce A. Smith <[bsmith@ccblaw.com](mailto:bsmith@ccblaw.com)>  
**Sent:** Monday, January 03, 2022 11:26 AM  
**To:** Ruberto, Laura <[RubertL@bsk.com](mailto:RubertL@bsk.com)>; Dave Quirello <[dquirello@cnycardiology.com](mailto:dquirello@cnycardiology.com)>; Shawna Papale <[spapale@mvedge.org](mailto:spapale@mvedge.org)>; Mark Kaucher <[mkaucher@mvedge.org](mailto:mkaucher@mvedge.org)>

**Cc:** Romano, Linda <[romanol@bsk.com](mailto:romanol@bsk.com)>; David Quirello ([dquirello@cnycardiology.com](mailto:dquirello@cnycardiology.com))  
<[dquirello@cnycardiology.com](mailto:dquirello@cnycardiology.com)>  
**Subject:** RE: Central Utica Building, LLC/Oneida County IDA

**External Email:** Use caution before clicking links or opening attachments.

Only comment is that the building size is now approx. 94,000 sf

Bruce A. Smith, Esq.  
Cohen Compagni Beckman Appler & Knoll, PLLC  
507 Plum Street, Suite 310  
Syracuse, New York 13204  
Direct Phone: (315) 477-6291  
Direct Fax: (315) 425-3691  
E-mail: [bsmith@ccblaw.com](mailto:bsmith@ccblaw.com)  
Website: [www.ccblaw.com](http://www.ccblaw.com)

**This electronic transmission contains information from the law firm of Cohen Compagni Beckman Appler & Knoll, PLLC, which is confidential, covered by the attorney-client privilege, and solely for the person or entity named above. If you are not the intended recipient, be aware that any disclosure, copying, distribution or use of this information is prohibited. If you have received this electronic mail transmission in error, please notify us by telephone, mail or electronic mail and destroy this communication.**

**From:** Ruberto, Laura <[RubertL@bsk.com](mailto:RubertL@bsk.com)>  
**Sent:** Monday, January 3, 2022 9:04 AM  
**To:** Dave Quirello <[dquirello@cnycardiology.com](mailto:dquirello@cnycardiology.com)>; Shawna Papale <[spapale@mvedge.org](mailto:spapale@mvedge.org)>; Mark Kaucher <[mkaucher@mvedge.org](mailto:mkaucher@mvedge.org)>; Bruce A. Smith <[bsmith@ccblaw.com](mailto:bsmith@ccblaw.com)>  
**Cc:** Romano, Linda <[romanol@bsk.com](mailto:romanol@bsk.com)>  
**Subject:** Central Utica Building, LLC/Oneida County IDA

Good morning; the IDA must conduct a public hearing relating to the proposed amended financial assistance. Attached is a legal notice for that purpose – a clean version and a redline version compared against the original legal notice is attached for review.

If we can publish by noon tomorrow, the hearing can be conducted any time after Monday, January 17<sup>th</sup>. Mark/Shawna, would you like to suggest some dates convenient to the IDA?

Best,  
Laura

**Laura S. Ruberto**  
Paralegal  
Business  
315.738.1223 Direct  
315.724.2074 Fax  
[lruberto@bsk.com](mailto:lruberto@bsk.com)

501 Main Street, Utica, NY 13501-1245

This email is ONLY for the person(s) named in the message header. Unless otherwise indicated, it contains information that is confidential, privileged or exempt from disclosure under applicable law. If you have received it in error, please notify the sender of the error and delete the message.

IRS regulations require us to notify you that any tax advice contained in this communication (including any attachments) is not intended or written to be used, and cannot be used, for the purpose of avoiding penalties under the Internal Revenue Code. If you want a further description of this requirement, go to <https://www.irs.com/irs/amtvr>.

**CAUTION: This email originated from outside of the organization. Do not click links or open attachments unless you recognize the sender and know the content is safe.**





## NOTICE OF PUBLIC HEARING

NOTICE IS HEREBY GIVEN that a public hearing pursuant to Article 18-A of the New York State General Municipal Law, will be held by the Oneida County Industrial Development Agency (the "Agency") on the \_\_\_\_\_ day of January 2022 at \_\_\_\_\_ 10:00 a.m., local time, at Oneida County Legislative Chambers, 10<sup>th</sup> Floor, Oneida County Office Building, 800 Park Avenue, Utica, New York in connection with the following matters:

Central Utica Building, LLC, on behalf of itself and/or the principals of Central Utica Building, LLC, and/or an entity formed or to be formed on behalf of any of the foregoing (collectively, the "Company") has applied to the Oneida County Industrial Development Agency (the "Agency") to enter into a transaction in which the Agency will assist in the construction of ~~an 80,000±~~ a 94,000± square foot state-of-the-art medical office building and appurtenant facilities including parking areas and all infrastructure, utilities and amenities to support the same (collectively, the "Improvements") situated on parcels of land measuring 2.90± acres in the aggregate adjacent to the new Wynn Hospital (the "Wynn Hospital") located at the Corner of State and Columbia Streets, City of Utica, Oneida County, New York (the "Land") and acquisition and installation of equipment in the Improvements (the "Equipment"), all for the purpose of providing a seamless and integrated health care delivery system together with the Wynn Hospital, and to enhance and expand the delivery of health care services to the community (the Land, the Improvements and the Equipment are referred to collectively as the "Facility" and the construction and equipping of the Improvements is referred to as the "Project"). The Facility will be initially operated and/or managed by the Company.

The Company will lease the Facility to the Agency, and the Agency will lease the Facility back to the Company pursuant to a leaseback agreement. At the end of the lease term, the Agency will terminate its leasehold interest in the Facility. The Company will sublease a 20,000± square foot portion of the Facility to Central New York Cardiology, P.C. (the "CNYC Sublessee") for its operation for the purpose of performing interventional cardiology services at the Wynn Hospital, to take cardiology call and provide cardiology services to patients admitted to the Wynn Hospital. The Company will sublease an 18,000± square foot portion of the Facility to Mohawk Valley ASC, LLC (the "MVASC Sublessee") for its operation for the purpose of operating an Article 28 licensed, Medicare certified multi-specialty ambulatory surgery center with six operating rooms. The Company will sublease other portions of the Facility to MVHS and other medical practices whose physicians practice in, and need access to, the Wynn Hospital, and to other commercial and/or retail tenants to provide complementary services (such sublessees, together with the CNYC Sublessee and the MVASC Sublessee, are referred to collectively as the "Sublessees").

The Agency ~~is~~ was contemplating providing financial assistance in the form of exemptions from mortgage recording taxes and exemptions from sales tax on materials and equipment acquired and installed in connection with the Project, such sales tax exemption limited to \$500,000, which financial assistance ~~is consistent with~~ was a

deviation from the Agency's Uniform Tax Exemption Policy (the "Policy"). The Agency conducted a public hearing on December 10, 2021 to hear and accept written comments from all persons with views in favor of or opposed to either the proposed financial assistance or the location or nature of the Facility. The Agency is now contemplating providing financial assistance in the form of exemptions from mortgage recording taxes and exemptions from sales tax on all taxable materials and equipment acquired and installed in connection with the Project, which financial assistance is consistent with the Policy, to be more particularly described in a Final Authorizing Resolution to be adopted by the Agency prior to the closing of the transactions described herein. Such financial assistance will be conditioned upon the Company creating, retaining and maintaining (or causing the Sublessees to create, retain and maintain) certain employment at the Facility as a result of undertaking the Project.

A representative of the Agency will at the above-stated time and place hear and accept written comments from all persons with views in favor of or opposed to either the proposed amended financial assistance to the Company or the location or nature of the Facility. Comments may also be submitted to the Agency in writing or electronically prior to the Public Hearing. Members of the public may also listen to the Public Hearing by calling 1-408-418-9388 (Access code: 263 377 79443). Minutes of the Public Hearing will be transcribed and posted on the Agency's website. A copy of the Application for Financial Assistance filed by the Company with the Agency, including an analysis of the costs and benefits of the proposed Project, is available for public inspection at the offices of the Agency, 584 Phoenix Drive, Rome, New York.

ONEIDA COUNTY INDUSTRIAL  
DEVELOPMENT AGENCY

Dated: January 34, 2022

By: /s/ Shawna M. Papale, Executive Director

## NOTICE OF PUBLIC HEARING

NOTICE IS HEREBY GIVEN that a public hearing pursuant to Article 18-A of the New York State General Municipal Law, will be held by the Oneida County Industrial Development Agency (the "Agency") on the \_\_\_\_\_ day of January 2022 at 10:00 a.m., local time, at Oneida County Legislative Chambers, 10<sup>th</sup> Floor, Oneida County Office Building, 800 Park Avenue, Utica, New York in connection with the following matters:

Central Utica Building, LLC, on behalf of itself and/or the principals of Central Utica Building, LLC, and/or an entity formed or to be formed on behalf of any of the foregoing (collectively, the "Company") has applied to the Oneida County Industrial Development Agency (the "Agency") to enter into a transaction in which the Agency will assist in the construction of a 94,000± square foot state-of-the-art medical office building and appurtenant facilities including parking areas and all infrastructure, utilities and amenities to support the same (collectively, the "Improvements") situated on parcels of land measuring 2.90± acres in the aggregate adjacent to the new Wynn Hospital (the "Wynn Hospital") located at the Corner of State and Columbia Streets, City of Utica, Oneida County, New York (the "Land") and acquisition and installation of equipment in the Improvements (the "Equipment"), all for the purpose of providing a seamless and integrated health care delivery system together with the Wynn Hospital, and to enhance and expand the delivery of health care services to the community (the Land, the Improvements and the Equipment are referred to collectively as the "Facility" and the construction and equipping of the Improvements is referred to as the "Project"). The Facility will be initially operated and/or managed by the Company.

The Company will lease the Facility to the Agency, and the Agency will lease the Facility back to the Company pursuant to a leaseback agreement. At the end of the lease term, the Agency will terminate its leasehold interest in the Facility. The Company will sublease a 20,000± square foot portion of the Facility to Central New York Cardiology, P.C. (the "CNYC Sublessee") for its operation for the purpose of performing interventional cardiology services at the Wynn Hospital, to take cardiology call and provide cardiology services to patients admitted to the Wynn Hospital. The Company will sublease an 18,000± square foot portion of the Facility to Mohawk Valley ASC, LLC (the "MVASC Sublessee") for its operation for the purpose of operating an Article 28 licensed, Medicare certified multi-specialty ambulatory surgery center with six operating rooms. The Company will sublease other portions of the Facility to MVHS and other medical practices whose physicians practice in, and need access to, the Wynn Hospital, and to other commercial and/or retail tenants to provide complementary services (such sublessees, together with the CNYC Sublessee and the MVASC Sublessee, are referred to collectively as the "Sublessees").

The Agency was contemplating providing financial assistance in the form of exemptions from mortgage recording taxes and exemptions from sales tax on materials and equipment acquired and installed in connection with the Project, such sales tax exemption limited to \$500,000, which financial assistance was a deviation from the Agency's Uniform Tax Exemption Policy (the "Policy"). The Agency conducted a public

hearing on December 10, 2021 to hear and accept written comments from all persons with views in favor of or opposed to either the proposed financial assistance or the location or nature of the Facility. The Agency is now contemplating providing financial assistance in the form of exemptions from mortgage recording taxes and exemptions from sales tax on all taxable materials and equipment acquired and installed in connection with the Project, which financial assistance is consistent with the Policy, to be more particularly described in a Final Authorizing Resolution to be adopted by the Agency prior to the closing of the transactions described herein. Such financial assistance will be conditioned upon the Company creating, retaining and maintaining (or causing the Sublessees to create, retain and maintain) certain employment at the Facility as a result of undertaking the Project.

A representative of the Agency will at the above-stated time and place hear and accept written comments from all persons with views in favor of or opposed to either the proposed amended financial assistance or the location or nature of the Facility. Comments may also be submitted to the Agency in writing or electronically prior to the Public Hearing. Members of the public may listen to the Public Hearing by calling 1-408-418-9388 (Access code: 263 377 79443). Minutes of the Public Hearing will be transcribed and posted on the Agency's website. A copy of the Application for Financial Assistance filed by the Company with the Agency, including an analysis of the costs and benefits of the proposed Project, is available for public inspection at the offices of the Agency, 584 Phoenix Drive, Rome, New York.

ONEIDA COUNTY INDUSTRIAL  
DEVELOPMENT AGENCY

Dated: January 4, 2022

By: /s/ Shawna M. Papale, Executive Director

**From:** [Dave Quirello](#)  
**To:** [Ruberto, Laura](#); ["Bruce A. Smith"](#); [Shawna Papale](#); [Mark Kaucher](#)  
**Cc:** ["Romano, Linda"](#)  
**Subject:** RE: Central Utica Building, LLC/Oneida County IDA  
**Date:** Tuesday, January 4, 2022 11:19:38 AM  
**Attachments:** [image001.png](#)

---

Good morning,

I think it is a good idea to move forward asap. I will forward to Bob, Lou and Dr. Kelberman.

David Quirello, CMPE  
Chief Financial Officer



**Central New York Cardiology**

2211 Genesee Street  
Utica NY 13501  
Phone: (315) 733-7598 ext. 2236  
Fax: (315) 733-7694  
[dquirello@cnycardiology.com](mailto:dquirello@cnycardiology.com)

**From:** Ruberto, Laura [<mailto:RubertL@bsk.com>]  
**Sent:** Tuesday, January 4, 2022 10:48 AM  
**To:** Bruce A. Smith <[bsmith@ccblaw.com](mailto:bsmith@ccblaw.com)>; Dave Quirello <[dquirello@cnycardiology.com](mailto:dquirello@cnycardiology.com)>; Shawna Papale <[spapale@mvedge.org](mailto:spapale@mvedge.org)>; Mark Kaucher <[mkaucher@mvedge.org](mailto:mkaucher@mvedge.org)>  
**Cc:** Romano, Linda <[romanol@bsk.com](mailto:romanol@bsk.com)>  
**Subject:** RE: Central Utica Building, LLC/Oneida County IDA

Good morning – attached is a revised legal notice, incorporating Bruce's revision below and clarifying the history of the action taken by the IDA.

The IDA would like to conduct the public hearing prior to the January 21 meeting, despite the fact that Dave will not be available. **Bruce**, will you be able to participate in the hearing in his stead?

If we submit today we do have time to meet notice requirements and conduct the hearing the week of January 17. Please let us know when a date is confirmed and we will finalize the notice for publication.

Thank you,  
Laura

**Laura S. Ruberto**  
315.738.1223 Direct

**From:** Bruce A. Smth <[bsmith@ccblaw.com](mailto:bsmith@ccblaw.com)>  
**Sent:** Monday, January 03, 2022 11:26 AM

**To:** Ruberto, Laura <[RubertL@bsk.com](mailto:RubertL@bsk.com)>; Dave Quirello <[dquirello@cnycardiology.com](mailto:dquirello@cnycardiology.com)>; Shawna Papale <[spapale@mvedge.org](mailto:spapale@mvedge.org)>; Mark Kaucher <[mkaucher@mvedge.org](mailto:mkaucher@mvedge.org)>  
**Cc:** Romano, Linda <[romanol@bsk.com](mailto:romanol@bsk.com)>; David Quirello (<[dquirello@cnycardiology.com](mailto:dquirello@cnycardiology.com)>  
<[dquirello@cnycardiology.com](mailto:dquirello@cnycardiology.com)>  
**Subject:** RE: Central Utica Building, LLC/Oneida County IDA

**External Email: Use caution before clicking links or opening attachments.**

Only comment is that the building size is now approx. 94,000 sf

Bruce A. Smith, Esq.  
Cohen Compagni Beckman Appler & Knoll, PLLC  
507 Plum Street, Suite 310  
Syracuse, New York 13204  
Direct Phone: (315) 477-6291  
Direct Fax: (315) 425-3691  
E-mail: [bsmith@ccblaw.com](mailto:bsmith@ccblaw.com)  
Website: [www.ccblaw.com](http://www.ccblaw.com)

**This electronic transmission contains information from the law firm of Cohen Compagni Beckman Appler & Knoll, PLLC, which is confidential, covered by the attorney-client privilege, and solely for the person or entity named above. If you are not the intended recipient, be aware that any disclosure, copying, distribution or use of this information is prohibited. If you have received this electronic mail transmission in error, please notify us by telephone, mail or electronic mail and destroy this communication.**

**From:** Ruberto, Laura <[RubertL@bsk.com](mailto:RubertL@bsk.com)>  
**Sent:** Monday, January 3, 2022 9:04 AM  
**To:** Dave Quirello <[dquirello@cnycardiology.com](mailto:dquirello@cnycardiology.com)>; Shawna Papale <[spapale@mvedge.org](mailto:spapale@mvedge.org)>; Mark Kaucher <[mkaucher@mvedge.org](mailto:mkaucher@mvedge.org)>; Bruce A. Smith <[bsmith@ccblaw.com](mailto:bsmith@ccblaw.com)>  
**Cc:** Romano, Linda <[romanol@bsk.com](mailto:romanol@bsk.com)>  
**Subject:** Central Utica Building, LLC/Oneida County IDA

Good morning; the IDA must conduct a public hearing relating to the proposed amended financial assistance. Attached is a legal notice for that purpose – a clean version and a redline version compared against the original legal notice is attached for review.

If we can publish by noon tomorrow, the hearing can be conducted any time after Monday, January 17<sup>th</sup>. **Mark/Shawna**, would you like to suggest some dates convenient to the IDA?

Best,  
Laura

**Laura S. Ruberto**  
Paralegal  
Business  
315.738.1223 Direct  
315.724.2074 Fax  
[lruberto@bsk.com](mailto:lruberto@bsk.com)

---

501 Main Street, Utica, NY 13501-1245

This email is ONLY for the person(s) named in the message header. Unless otherwise indicated, it contains information that is confidential, privileged or exempt from disclosure under applicable law. If you have received it in error, please notify the sender of the error and delete the message.

IRS regulations require us to notify you that any tax advice contained in this communication (including any attachments) is not intended or written to be used, and cannot be used, for the purpose of avoiding penalties under the Internal Revenue Code. If you want a further description of this requirement, go to <https://www.irs.com/disclaimer>.

**CAUTION: This email originated from outside of the organization. Do not click links or open attachments unless you recognize the sender and know the content is safe.**





## Ruberto, Laura

---

**From:** Ruberto, Laura  
**Sent:** Wednesday, January 05, 2022 1:04 PM  
**To:** Anthony J. Picente; llapolla@uticaschools.org; mayor@cityofutica.com; bkaram@uticaschools.org  
**Cc:** realproperty@ocgov.net; Pilbeam, Kathy; Carvelli, Anthony; Padron, Daisy; Brian McClusky; William Morehouse; Haylee Lallier; Romano, Linda; Richard Maxwell; Merima Smajic; 'Billard, Mike'; Shawna Papale (spapale@mvedge.org); Mark Kaucher  
**Subject:** Notice of Public Hearing: Central Utica Building, LLC/Oneida County IDA  
**Attachments:** notice of public hearing (CUB)(13374231.4).pdf

Tracking:	Recipient	Delivery
	Anthony J. Picente	
	llapolla@uticaschools.org	
	mayor@cityofutica.com	
	bkaram@uticaschools.org	
	realproperty@ocgov.net	
	Pilbeam, Kathy	
	Carvelli, Anthony	
	Padron, Daisy	
	Brian McClusky	
	William Morehouse	
	Haylee Lallier	
	Romano, Linda	Delivered: 1/5/2022 1:09 PM
	Richard Maxwell	
	Merima Smajic	
	'Billard, Mike'	
	Shawna Papale (spapale@mvedge.org)	
	Mark Kaucher	
	Oneida County Industrial Development Age_Central Utica Building_ LLC Lease_Leaseb_033807_427270_ _Email and Correspondence	

On **January 18, 2022 at 10:00 a.m.**, local time, the Oneida County Industrial Development Agency (the "Agency") will conduct a second public hearing for a project for **Central Utica Building, LLC**. Attached is a copy of the Notice of Public Hearing describing the project and the proposed amended financial assistance contemplated by the Agency. The Notice has been submitted to the *Observer-Dispatch*, Utica, New York for publication.

You are welcome to attend such hearing and provide comments on the nature of the Facility and the provision of financial assistance. We are providing this notice to you, pursuant to Chapters 356 and 357 of the Laws of 1993, as the chief executive officer of an affected tax jurisdiction within which the project is located.

Should you desire to discuss this matter or if you have any questions concerning this notice please feel free to contact Shawna Papale at the Agency at telephone number 315-338-0393.

Be well,  
Laura

**Laura S. Ruberto**  
Paralegal  
Business  
315.738.1223 Direct  
315.724.2074 Fax  
[lruberto@bsk.com](mailto:lruberto@bsk.com)



501 Main Street, Utica, NY 13501-1245

This email is ONLY for the person(s) named in the message header. Unless otherwise indicated, it contains information that is confidential, privileged or exempt from disclosure under applicable law. If you have received it in error, please notify the sender of the error and delete the message.

IRS regulations require us to notify you that any tax advice contained in this communication (including any attachments) is not intended or written to be used, and cannot be used, for the purpose of avoiding penalties under the Internal Revenue Code. If you want a further description of this requirement, go to <https://www.bsk.com/disclaimer>.

**From:** Ruberto, Laura

**Sent:** Tuesday, November 23, 2021 8:14 AM

**To:** Anthony J. Picente <[apicente@ocgov.net](mailto:apicente@ocgov.net)>; [llapolla@uticaschools.org](mailto:llapolla@uticaschools.org); [mayor@cityofutica.com](mailto:mayor@cityofutica.com); [bkaram@uticaschools.org](mailto:bkaram@uticaschools.org)

**Cc:** [realproperty@ocgov.net](mailto:realproperty@ocgov.net); Pilbeam, Kathy <[kpilbeam@ocgov.net](mailto:kpilbeam@ocgov.net)>; Carvelli, Anthony <[carvelli@ocgov.net](mailto:carvelli@ocgov.net)>; Padron, Daisy <[dpadron@ocgov.net](mailto:dpadron@ocgov.net)>; Brian McClusky <[bmccclusky@cityofutica.com](mailto:bmccclusky@cityofutica.com)>; William Morehouse <[wmorehouse@cityofutica.com](mailto:wmorehouse@cityofutica.com)>; Haylee Lallier <[hlallier@uticaschools.org](mailto:hlallier@uticaschools.org)>; Romano, Linda <[Romanol@bsk.com](mailto:Romanol@bsk.com)>; Richard Maxwell <[rmaxwell@cityofutica.com](mailto:rmaxwell@cityofutica.com)>; Merima Smajic <[mismajic@cityofutica.com](mailto:mismajic@cityofutica.com)>; 'Billard, Mike' <[mbillard@ocgov.net](mailto:mbillard@ocgov.net)>; Shawna Papale ([spapale@mvedge.org](mailto:spapale@mvedge.org)) <[spapale@mvedge.org](mailto:spapale@mvedge.org)>; Mark Kaucher <[mkaucher@mvedge.org](mailto:mkaucher@mvedge.org)>

**Subject:** Notice of Public Hearing: Central Utica Building, LLC/Oneida County IDA

On **December 10, 2021 at 10:00 a.m.**, local time, the Oneida County Industrial Development Agency (the "Agency") will conduct a public hearing regarding a project for **Central Utica Building, LLC**. Attached is a copy of the Notice of Public Hearing describing the project and the financial assistance contemplated by the Agency. The Notice has been submitted to the *Observer-Dispatch*, Utica, New York for publication.

You are welcome to attend such hearing and provide comments on the nature of the Facility and the provision of financial assistance. We are providing this notice to you, pursuant to Chapters 356 and 357 of the Laws of 1993, as the chief executive officer of an affected tax jurisdiction within which the project is located.

Should you desire to discuss this matter or if you have any questions concerning this notice please feel free to contact Shawna Papale at the Agency at telephone number 315-338-0393.

Be well,  
Laura

**Laura S. Ruberto**  
Paralegal

Business  
315.738.1223 Direct  
315.724.2074 Fax  
[lruberto@bsk.com](mailto:lruberto@bsk.com)



501 Main Street, Utica, NY 13501-1245

This email is ONLY for the person(s) named in the message header. Unless otherwise indicated, it contains information that is confidential, privileged or exempt from disclosure under applicable law. If you have received it in error, please notify the sender of the error and delete the message.

IRS regulations require us to notify you that any tax advice contained in this communication (including any attachments) is not intended or written to be used, and cannot be used, for the purpose of avoiding penalties under the Internal Revenue Code. If you want a further description of this requirement, go to <https://www.bsk.com/disclaimer>.



## NOTICE OF PUBLIC HEARING

NOTICE IS HEREBY GIVEN that a public hearing pursuant to Article 18-A of the New York State General Municipal Law, will be held by the Oneida County Industrial Development Agency (the "Agency") on the 18th day of January 2022 at 10:00 a.m., local time, at Oneida County Legislative Chambers, 10<sup>th</sup> Floor, Oneida County Office Building, 800 Park Avenue, Utica, New York in connection with the following matters:

Central Utica Building, LLC, on behalf of itself and/or the principals of Central Utica Building, LLC, and/or an entity formed or to be formed on behalf of any of the foregoing (collectively, the "Company") has applied to the Oneida County Industrial Development Agency (the "Agency") to enter into a transaction in which the Agency will assist in the construction of a 94,000± square foot state-of-the-art medical office building and appurtenant facilities including parking areas and all infrastructure, utilities and amenities to support the same (collectively, the "Improvements") situated on parcels of land measuring 2.90± acres in the aggregate adjacent to the new Wynn Hospital (the "Wynn Hospital") located at the Corner of State and Columbia Streets, City of Utica, Oneida County, New York (the "Land") and acquisition and installation of equipment in the Improvements (the "Equipment"), all for the purpose of providing a seamless and integrated health care delivery system together with the Wynn Hospital, and to enhance and expand the delivery of health care services to the community (the Land, the Improvements and the Equipment are referred to collectively as the "Facility" and the construction and equipping of the Improvements is referred to as the "Project"). The Facility will be initially operated and/or managed by the Company.

The Company will lease the Facility to the Agency, and the Agency will lease the Facility back to the Company pursuant to a leaseback agreement. At the end of the lease term, the Agency will terminate its leasehold interest in the Facility. The Company will sublease a 20,000± square foot portion of the Facility to Central New York Cardiology, P.C. (the "CNYC Sublessee") for its operation for the purpose of performing interventional cardiology services at the Wynn Hospital, to take cardiology call and provide cardiology services to patients admitted to the Wynn Hospital. The Company will sublease an 18,000± square foot portion of the Facility to Mohawk Valley ASC, LLC (the "MVASC Sublessee") for its operation for the purpose of operating an Article 28 licensed, Medicare certified multi-specialty ambulatory surgery center with six operating rooms. The Company will sublease other portions of the Facility to MVHS and other medical practices whose physicians practice in, and need access to, the Wynn Hospital, and to other commercial and/or retail tenants to provide complementary services (such sublessees, together with the CNYC Sublessee and the MVASC Sublessee, are referred to collectively as the "Sublessees").

The Agency was contemplating providing financial assistance in the form of exemptions from mortgage recording taxes and exemptions from sales tax on materials and equipment acquired and installed in connection with the Project, such sales tax exemption limited to \$500,000, which financial assistance was a deviation from the Agency's Uniform Tax Exemption Policy (the "Policy"). The Agency conducted a public

hearing on December 10, 2021 to hear and accept written comments from all persons with views in favor of or opposed to either the proposed financial assistance or the location or nature of the Facility. The Agency is now contemplating providing financial assistance in the form of exemptions from mortgage recording taxes and exemptions from sales tax on all taxable materials and equipment acquired and installed in connection with the Project, which financial assistance is consistent with the Policy, to be more particularly described in a Final Authorizing Resolution to be adopted by the Agency prior to the closing of the transactions described herein. Such financial assistance will be conditioned upon the Company creating, retaining and maintaining (or causing the Sublessees to create, retain and maintain) certain employment at the Facility as a result of undertaking the Project.

A representative of the Agency will at the above-stated time and place hear and accept written comments from all persons with views in favor of or opposed to either the proposed amended financial assistance or the location or nature of the Facility. Comments may also be submitted to the Agency in writing or electronically prior to the Public Hearing. Members of the public may listen to the Public Hearing by calling 1-408-418-9388 (Access code: 263 489 89116). Minutes of the Public Hearing will be transcribed and posted on the Agency's website. A copy of the Application for Financial Assistance filed by the Company with the Agency, including an analysis of the costs and benefits of the proposed Project, is available for public inspection at the offices of the Agency, 584 Phoenix Drive, Rome, New York.

ONEIDA COUNTY INDUSTRIAL  
DEVELOPMENT AGENCY

Dated: January 4, 2022

By: /s/ Shawna M. Papale, Executive Director

Anthony J. Picente Jr.  
County Executive

Shawna M. Papale  
Secretary/  
Executive Director

Jennifer Waters  
Assistant Secretary

ONEIDA COUNTY INDUSTRIAL  
DEVELOPMENT AGENCY



584 Phoenix Drive  
Rome, New York 13441-4105  
(315) 338-0393, fax (315) 338-5694

David C. Grow  
Chairman

Michael Fitzgerald  
Vice Chairman

Mary Faith Messenger  
Treasurer

Ferris Betrus Jr.  
Eugene Quadraro  
Stephen Zogby  
Kirk Hinman

January 13, 2022

**VIA ELECTRONIC MAIL:** [pdonnelly@bdflegal.com](mailto:pdonnelly@bdflegal.com)

Patrick D. Donnelly, Esq.  
Brown Duke & Fogel, P.C.  
120 Madison Street, Suite 1620  
Syracuse NY 13202

**Re: FOIL Request Regarding Central Utica Building, LLC  
Application for Financial Assistance**

Dear Mr. Donnelly:

Oneida County Industrial Development Agency has reviewed its records relating to the above-referenced subject. Attached please find all documents that we believe to be responsive to your request. We are not delivering confidential communication between the IDA and our attorneys that is protected under CPLR § 4503(A)(1), as the IDA claims and has not waived that privilege.

Thank you.

Very truly yours,

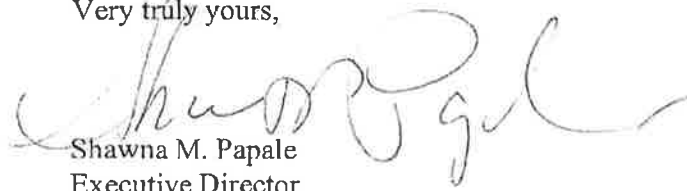
  
Shawna M. Papale  
Executive Director

SMP/lsr

Attachment

c: Linda E. Romano, Esq.  
Mark D. Levitt, Esq.

# **EXHIBIT B**



# BROWN DUKE & FOGEL, P.C.

ATTORNEYS AND COUNSELORS AT LAW  
WWW.BDFLEGAL.COM

Patrick D. Donnelly, Esq.  
Brown Duke & Fogel, P.C.  
120 Madison Street, Suite 1620  
Syracuse, New York 13202  
[pdonnelly@bdflegal.com](mailto:pdonnelly@bdflegal.com)  
Tel: 315-399-4343

January 21, 2022

## **Via Email**

Shawna Papale, Secretary/Executive Director  
Oneida County Industrial Development Agency  
584 Phoenix Drive  
Rome, New York 13441-4105  
[info@mvedge.org](mailto:info@mvedge.org)  
[spapale@mvedge.org](mailto:spapale@mvedge.org)

### **Re: FOIL request regarding Central Utica Building, LLC Application for Financial Assistance**

Dear Executive Director Papale:

This is a request pursuant to the Freedom of Information Law ("FOIL") for copies of the following public records:

1. All updates and amendments to the Central Utica Building, LLC Application for Financial Assistance (the "Application"), which Application was submitted on or about November 12, 2021 to the Oneida County Industrial Development Agency ("OCIDA").
2. All application materials submitted with or related to the Application, including but not limited to all cost-benefit analysis submissions and all completed forms regarding the State Environmental Quality Review Act ("SEQRA") such as all completed Environmental Assessment Forms ("EAFs").
3. All resolution(s) adopted as to the following agenda items on the agenda for the January 21, 2022 OCIDA meeting:
  - a. Agenda item # 4 "Consider a SEQR resolution relating to the Central Utica Building, LLC facility. The City of Utica Planning Board acted as lead agency and the Agency is adopting the findings and determinations of the lead agency."
  - b. Agenda item # 5 "Consider a statement of findings relating to the Central Utica Building LLC facility and request the Oneida County Executive confirm the provision of financial assistance to the facility."
  - c. Agenda item # 6 "Consider the request of Central Utica Building, LLC ("CUB") that the OCIDA commence condemnation proceedings pursuant to Article 2 of the Eminent Domain Procedure Law ("EDPL") to obtain a parcel of land known as 411 Columbia Street (SBL No.: 318.41-2-38) in the City of Utica which parcel is necessary to provide adequate parking for a 94,000 square foot medical office building and ambulatory surgery center that is being constructed on an adjacent parcel and schedule a public hearing for same."

4. All documents, letters, correspondence, notices, resolutions and other records discussed, referenced or considered at the January 21, 2022 OCIDA meeting as to the above listed agenda items.
5. The letter by Bruce Smith discussed during the January 21, 2022 OCIDA meeting related to the above referenced agenda item # 6 or eminent domain.
6. All notices of public hearing related to the above referenced agenda item # 6, including but not limited to any notice as to an upcoming hearing on taking by eminent domain the above referenced parcel of land known as 411 Columbia Street (SBL No.: 318.41-2-38).
7. All letters, emails and other correspondence to, from or between Central Utica Building, LLC ("CUB") or its agents or attorneys and OCIDA or OCIDA board members, staff, agents or attorneys regarding the Application or taking by eminent domain the above referenced parcel of land known as 411 Columbia Street (SBL No.: 318.41-2-38).
8. All letters, emails and other correspondence to, from or between Mohawk Valley Health System ("MVHS") or its agents or attorneys and OCIDA or OCIDA board members, staff, agents or attorneys regarding the Application or taking by eminent domain the above referenced parcel of land known as 411 Columbia Street (SBL No.: 318.41-2-38).

If you deny any of these requests, please cite each exemption you feel justifies the denial and notify me of the appeal procedures. Thank you.

Sincerely,  
BROWN DUKE & FOGEL, P.C.

By:   
Patrick D. Donnelly, Esq.

# **EXHIBIT C**

Anthony J. Picente Jr.  
County Executive

Shawna M. Papale  
Secretary/  
Executive Director

Jennifer Waters  
Assistant Secretary

ONEIDA COUNTY INDUSTRIAL  
DEVELOPMENT AGENCY

**OCIDA**



584 Phoenix Drive  
Rome, New York 13441-4105  
(315) 338-0393, fax (315) 338-5694

David C. Grow  
Chairman

Michael Fitzgerald  
Vice Chairman

Mary Faith Messenger  
Treasurer

Ferris Belrus Jr.  
Eugene Quadraro  
Stephen Zogby  
Kirk Hinman

January 27, 2022

**VIA ELECTRONIC MAIL: [pdonnelly@bdflegal.com](mailto:pdonnelly@bdflegal.com)**

Patrick D. Donnelly, Esq.  
Brown Duke & Fogel, P.C.  
120 Madison Street, Suite 1620  
Syracuse NY 13202

**Re: Request for Access to Records under New York State Freedom of Information Law Regarding  
Central Utica Building, LLC**

Dear Mr. Donnelly:

We write to acknowledge receipt of your request for documents relating to the Central Utica Building, LLC Facility in Utica, New York.

The IDA will review the file you referenced and determine whether the documents contained therein are responsive to your request and are not subject to an exception under Public Officers Law §87. We estimate we will require twenty (20) business days to make that determination and to locate the records you requested.

Please do not hesitate to contact me if you wish to discuss this request.

Very truly yours,

Shawna M. Papale  
Executive Director

# **EXHIBIT D**

Anthony J. Picente Jr.  
County Executive

Shawna M. Papale  
Secretary/  
Executive Director

Jennifer Waters  
Assistant Secretary

ONEIDA COUNTY INDUSTRIAL  
DEVELOPMENT AGENCY



584 Phoenix Drive  
Rome, New York 13441-4105  
(315) 338-0393, fax (315) 338-5694

David C. Grow  
Chairman

Michael Fitzgerald  
Vice Chairman

Mary Faith Messenger  
Treasurer

Ferris Betrus Jr.  
Eugene Quadraro  
Stephen Zogby  
Kirk Hinman

February 15, 2022

**VIA ELECTRONIC MAIL: [pdonnelly@bdflegal.com](mailto:pdonnelly@bdflegal.com)**

Patrick D. Donnelly, Esq.  
Brown Duke & Fogel, P.C.  
120 Madison Street, Suite 1620  
Syracuse NY 13202

**Re: Request for Access to Records under New York State Freedom of Information Law Regarding  
Central Utica Building, LLC - Extension**

Dear Mr. Donnelly:

We write to acknowledge receipt of your request for documents relating to the Central Utica Building, LLC Facility in Utica, New York.

The IDA will review the file you referenced and determine whether the documents contained therein are responsive to your request and are not subject to an exception under Public Officers Law §87. We estimate we will require an additional thirty (30) business days to make that determination and to locate the records you requested.

Please do not hesitate to contact me if you wish to discuss this request.

Very truly yours,

Shawna M. Papale  
Executive Director

# **EXHIBIT E**

**Patrick Donnelly**

---

**From:** Paul Goldman <PGoldman@goldmanpllc.com>  
**Sent:** Tuesday, March 1, 2022 3:04 PM  
**To:** Patrick Donnelly; Jennifer Waters  
**Cc:** Shawna Papale; Michael Fogel  
**Subject:** RE: Letters to OCIDA objecting to taking 411 Columbia Street by eminent domain

Patrick:

I will advise you when it is ready.

**Paul J. Goldman, Esq.**

Goldman Attorneys PLLC  
255 Washington Avenue Extension, Suite 108  
Albany, New York 12205  
Direct Dial: (518) 275-4411  
Office: (518) 431-0941 Ext. 105 | Fax: (518) 694-4821 | Email: [pgoldman@goldmanpllc.com](mailto:pgoldman@goldmanpllc.com)

The information contained in this message contains information from Goldman Attorneys PLLC, which is confidential or privileged. The information is intended for the use of the individual or entity named above. If you are not the intended recipient, be aware that any disclosure, copying, distribution or use of the contents of this communication is prohibited. If you have received this e-mail message in error, please destroy this message and notify the sender by reply e-mail. Thank you.

Disclosure under IRS Circular 230: Unless expressly stated otherwise, nothing contained in this communication is intended or written to be used, nor may it be relied upon or used, (1) by any taxpayer for the purpose of avoiding penalties that may be imposed under the Internal Revenue Code, and/or (2) by any person to support the promotion or marketing of or to recommend any Federal tax transaction(s) or matter(s) addressed in this communication.

**From:** Patrick Donnelly <[pdonnelly@bdflegal.com](mailto:pdonnelly@bdflegal.com)>  
**Sent:** Tuesday, March 1, 2022 3:00 PM  
**To:** Jennifer Waters <[jwaters@mvedge.org](mailto:jwaters@mvedge.org)>  
**Cc:** Paul Goldman <PGoldman@goldmanpllc.com>; Shawna Papale <[spapale@mvedge.org](mailto:spapale@mvedge.org)>; Michael Fogel <[mfogel@bdflegal.com](mailto:mfogel@bdflegal.com)>  
**Subject:** RE: Letters to OCIDA objecting to taking 411 Columbia Street by eminent domain

Jennifer,

When can I come by and inspect and copy the below referenced documents, legal descriptions, maps and project information? Can I just come by, or do I need an appointment?

**Patrick D. Donnelly, Esq.**

BROWN DUKE & FOGEL, P.C.  
120 Madison Street, AXA Tower 2, Suite 1620  
Syracuse, New York 13202  
Phone: (315) 399-4343, x206  
Fax: (315) 472-6215  
[pdonnelly@bdflegal.com](mailto:pdonnelly@bdflegal.com)  
<http://bdflegal.com/>

\*\*\*\*\*  
**Confidentiality Notice:** This e-mail transmission (including any attachments) is intended only for the use of the individual or entity to which it is addressed, and may contain information that is privileged, confidential, and exempt from disclosure under applicable law. If you are not the intended recipient, you are hereby notified that any disclosure, copying, distribution, or the taking of any action in reliance on the contents of this e-mail or any attachment is strictly prohibited. If you have received this transmission in error, please immediately notify the sender by return e-mail and delete all copies of this e-mail and any attachments.  
\*\*\*\*\*



**From:** Patrick Donnelly  
**Sent:** Friday, February 25, 2022 11:28 AM  
**To:** Jennifer Waters <[jwaters@mvedge.org](mailto:jwaters@mvedge.org)>  
**Cc:** PGoldman@goldmanpllc.com; Shawna Papale <[spapale@mvedge.org](mailto:spapale@mvedge.org)>; Michael Fogel <[mfogel@bdflegal.com](mailto:mfogel@bdflegal.com)>  
**Subject:** RE: Letters to OCIDA objecting to taking 411 Columbia Street by eminent domain

Jennifer,

Thank you for that, but what I called about was to see if I needed an appointment or could just come by and inspect and copy the documents listed in the following part of the hearing notice. When can I come by and inspect and copy the following referenced documents, legal descriptions, maps and project information?

The hearing notice states:

Availability of Additional Information

More particular information concerning the Additional Project Land proposed to be acquired by the OCIDA pursuant to the EDPL, including legal descriptions and maps, and the Project are available for public inspection during normal business hours at OCIDA, 584 Phoenix Drive, Rome, New York 13441.

*Patrick D. Donnelly, Esq.*  
BROWN DUKE & FOGEL, P.C.  
120 Madison Street, AXA Tower 2, Suite 1620  
Syracuse, New York 13202  
Phone: (315) 399-4343, x206  
Fax: (315) 472-6215  
[pdonnelly@bdflegal.com](mailto:pdonnelly@bdflegal.com)  
<http://bdflegal.com/>

\*\*\*\*\*  
**Confidentiality Notice:** This e-mail transmission (including any attachments) is intended only for the use of the individual or entity to which it is addressed, and may contain information that is privileged, confidential, and exempt from disclosure under applicable law. If you are not the intended recipient, you are hereby notified that any disclosure, copying, distribution, or the taking of any action in reliance on the contents of this e-mail or any attachment is strictly prohibited. If you have received this transmission in error, please immediately notify the sender by return e-mail and delete all copies of this e-mail and any attachments.  
\*\*\*\*\*

**From:** Jennifer Waters <[jwaters@mvedge.org](mailto:jwaters@mvedge.org)>  
**Sent:** Friday, February 25, 2022 10:16 AM  
**To:** Patrick Donnelly <[pdonnelly@bdflegal.com](mailto:pdonnelly@bdflegal.com)>; Michael Fogel <[mfogel@bdflegal.com](mailto:mfogel@bdflegal.com)>  
**Cc:** PGoldman@goldmanpllc.com; Shawna Papale <[spapale@mvedge.org](mailto:spapale@mvedge.org)>  
**Subject:** RE: Letters to OCIDA objecting to taking 411 Columbia Street by eminent domain

Morning Patrick,

Per your phone request to Tim Fitzgerald, please find attached the only other written statement, besides yours, that we have received in regards to the public hearing on Wednesday. Note that written comments have until March 2<sup>nd</sup> to be received. Thank you.

Jen

**Jennifer Waters**  
VP Business Development & Communications, Mohawk Valley EDGE  
315.338.0393 | [jwaters@mvedge.org](mailto:jwaters@mvedge.org) | [www.mvedge.org](http://www.mvedge.org)  
584 Phoenix Drive, Rome, NY 13441

Keep up to date with [EDGE on Facebook!](#)

**From:** Patrick Donnelly <[pdonnelly@bdflegal.com](mailto:pdonnelly@bdflegal.com)>  
**Sent:** Wednesday, February 23, 2022 7:13 AM  
**To:** Shawna Papale <[spapale@mvedge.org](mailto:spapale@mvedge.org)>; Info <[info@mvedge.org](mailto:info@mvedge.org)>  
**Cc:** PGoldman@goldmanpllc.com; Michael Fogel <[mfogel@bdflegal.com](mailto:mfogel@bdflegal.com)>  
**Subject:** Letters to OCIDA objecting to taking 411 Columbia Street by eminent domain

Dear Oneida County Industrial Development Agency:

Please see the attached letter from this firm and the attached letter from James P. O'Brien III objecting to taking by eminent domain the property at 411 Columbia Street, Utica, NY for the Central Utica Building, LLC ("CUB") project. Please include the attached in the record of the public hearing scheduled for February 23, 2022.

Thank you,

*Patrick D. Donnelly, Esq.*  
BROWN DUKE & FOGEL, P.C.  
120 Madison Street, AXA Tower 2, Suite 1620  
Syracuse, New York 13202  
Phone: (315) 399-4343, x206  
Fax: (315) 472-6215  
[pdonnelly@bdflegal.com](mailto:pdonnelly@bdflegal.com)  
<http://bdflegal.com/>

\*\*\*\*\*  
**Confidentiality Notice:** This e-mail transmission (including any attachments) is intended only for the use of the individual or entity to which it is addressed, and may contain information that is privileged, confidential, and exempt from disclosure under applicable law. If you are not the intended recipient, you are hereby notified that any disclosure, copying, distribution, or the taking of any action in reliance on the contents of this e-mail or any attachment is strictly prohibited. If you have received this transmission in error, please immediately notify the sender by return e-mail and delete all copies of this e-mail and any attachments.  
\*\*\*\*\*

**CAUTION:** This email originated from outside of the organization. Do not click links or open attachments unless you recognize the sender and know the content is safe.

# **EXHIBIT F**

From: Mark Harf

To: [mbillard@ocgov.net](mailto:mbillard@ocgov.net) <[mbillard@ocgov.net](mailto:mbillard@ocgov.net)>

Sent: Wed, Feb 23, 2022 7:02 pm

Subject: CUB MVHS Physicians and the Eminent Domain Case: OC Legislature Board Meeting Wed Feb 23

Greetings Oneida County Board of Legislators:

I am an Oneida County Taxpayer. I live at 805 Van Buren Street in Utica. Like all of you, I am also a patient of healthcare services in the Mohawk Valley.

Unfortunately, I was not aware that today's Oneida County Board Meeting was a public meeting. There should be a better strategy to promote these meetings, provide clarity on whether they are public, and overall openness in Oneida County Legislature Meetings (more push alerts, clearer descriptions in the news on what they are and who is the intended audience, etc.).

I do not support the use of eminent domain for 411 Columbia St. It seems that O'Brien Plumbing and Bowers Development have already entered into a contractual sale and that Bowers has a plan to create a better Medical Office Building than the MVHS Practicing Physicians who are disguising themselves under the moniker of CUB.

- It is NOT a good, legitimate, or financially prudent use of taxpayer funds to pursue an eminent domain case that does not meet the definition of the intended use of eminent domain and in a scenario in which there is no very clear public benefit. This is especially the case when there is also a concurrent risk of legal costs for having pursued in illegitimately.
- The hospital having been located downtown was to spur private sector development downtown. It sends the wrong message to Bowers AND other developers to fight their purchase and development plans. Development should not be restricted to 2 exclusive partners (i.e., MVHS and its affiliated Physicians). Your fiduciary obligation to taxpayers is to ensure that 'risk' is spread across multiple viable parties. It is not to pander to MVHS's personal wishes or to physicians who want to further build their personal wealth by dabbling in development.
- Development downtown should not be a matter of preferred partners to MVHS, especially when those partners are also affiliated with MVHS. It should be about diversifying partners, who engaged early, and who has the best plan in terms of design, scale, and scope.
- As a patient of healthcare services in the Mohawk Valley, I find it to be a potential conflict of interest to have the physicians servicing patients in the community to also be acting as real estate developers in the same community and in the same facilities in which they are providing care and also leading to a community hospital with which they are affiliated. I do not want to potentially be receiving care and charged for services guessing whether my care and my bill was influenced by the need to the finance real estate investments of the same healthcare practitioners who are providing care. If the CUB physicians wish to concurrently be in the real estate development business, they should do so in communities in which they are not providing care. Developers should be in the real estate development business and physicians should be in the business of providing patient care.
- I understand that at least one of the CUB physicians has not proven to be a good community citizen by having built a mid rise apartment building in a residential neighborhood of tiny bungalows in South Utica, when there was an option to achieve the same goal for its autistic residents via the creation of garden style homes much like the Roosevelt Residences in Cornhill. The new building on Sunset Ave is out of place and is already showing signs of contributing to neighborhood decay. This is not a good indicator of what may follow in downtown Utica.

I have no affiliations with MVHS, the CUB physicians, O'Brien Plumbing, Bowers Development, or any individuals associated with same. I am a local citizen and I am frustrated that political leadership in this region is not listening to local taxpayers in the journey surrounding this hospital. Please abandon the discussion around eminent domain, encourage MVHS to diversify their partner base, and let Bowers move forward as the developer of the medical office complex.

Please feel free to respond to this email and/or to reach me if you have any questions, 315-254-5794.

Thank you, Mark Harf

# BROWN DUKE & FOGEL, P.C.

ATTORNEYS AND COUNSELORS AT LAW

WWW.BDFLEGAL.COM

Michael A. Fogel, Esq.  
Brown Duke & Fogel, P.C.  
120 Madison Street, Suite 1620  
Syracuse, New York 13202  
[mfogel@bdflegal.com](mailto:mfogel@bdflegal.com)  
Tel: 315-399-4343

March 30, 2022

Oneida County Industrial Development Agency  
c/o Mohawk Valley Edge  
584 Phoenix Drive  
Rome, New York 13441  
[jwaters@mvedge.org](mailto:jwaters@mvedge.org)  
[info@mvedge.org](mailto:info@mvedge.org)  
[spapale@mvedge.org](mailto:spapale@mvedge.org)

**Re: Eminent Domain Procedure Law (“EDPL”) § 203 Public Hearing with respect to 411 Columbia Street, City of Utica, Oneida County, New York a/k/a SBL 318.41-2-38**

Dear Oneida County Industrial Development Agency:

This office represents Bowers Development, LLC and Utica Med Building, LLC (collectively “Bowers”). Please accept this letter as Bowers’ further objections and comments as to the EDPL, Article 2, Public Hearing (“Public Hearing”) by the Oneida County Industrial Development Agency (“OCIDA”) regarding its proposed taking by eminent domain of the property referred to as 411 Columbia Street, Utica, New York (SBL No.: 318.41-2-38) (the “Property”) for the proposed Central Utica Building, LLC Project (the “CUB Project”). As stated in OCIDA’s letter to us, written comments will be accepted through March 30, 2022 at 5:00 pm.

As discussed in our prior letters, it would be outrageous, unlawful, unconstitutional and an abuse of discretion for OCIDA to take the Property by eminent domain for the CUB Project as requested by Central Utica Building, LLC (“CUB”), which is made up of a group of doctors. This letter supplements and is in addition to our prior letters and comments.

First and foremost, for reasons stated below, OCIDA should hold another public hearing and extend the comment period to allow us and the public to comment on taking the Property by eminent domain.

We have been seeking to review the documents referenced in the purported hearing notice dated February 2, 2022, which states, “Availability of Additional Information: More particular information concerning the Additional Project Land proposed to be acquired by the OCIDA pursuant to the EDPL, including legal descriptions and maps, and the Project are available for public inspection during normal business hours at OCIDA, 584 Phoenix Drive, Rome, New York 13441.” It is apparent that was never made available to us and the public prior to the February 23, 2022 public hearing, and in fact, despite our repeated requests, it still has not been made available to us and the public.

On March 16, 2022, Paul Goldman, Esq. stated in a letter and email to my firm that the “record of the public hearing” was now available for inspection and copying at OCIDA’s office and the Oneida County Clerk’s office. This was not true (*see* attached hereto as **Exhibit A** an email regarding same by Patrick Donnelly, Esq., of my office, dated March 24, 2022, the email of Paul Goldman, Esq., dated March 16, 2022 and the letter of Paul Goldman, Esq., dated March 16, 2022). As detailed in the email from my office to Attorney Goldman, neither OCIDA nor the County Clerk’s Office was able to provide access to these documents, or at least in any comprehensive way that would allow us to reasonably conclude that the entire “record of the public hearing” was actually provided. It has to be stressed that the statutory burden is on the condemning authority to provide the complete record in a clear, comprehensive fashion to the public so that the public can meaningfully comment. The burden is certainly not on the public or the party whose property is proposed to be taken by eminent domain to figure out what constitutes the complete record. The fact that OCIDA continues to place the burden on the public and Bowers to “figure it out” is just more evidence of bad faith and a complete disregard for the rights of the public and Bowers.

Suffice it to say that OCIDA has still not provided the full record of the public hearing for inspection and copying by us and the public at OCIDA’s office and the Oneida County Clerk’s office (*see* Exhibit A). What OCIDA has posted on its website is not consistent with what it provided to us at OCIDA’s office and with what OCIDA provided to the Oneida County Clerk’s office (*see e.g.* Exhibit A). The pdf posted on OCIDA’s website is 1,165 pages while the documents at the Oneida County Clerk’s office appear to be 7,000 pages long. When you search instrument number F2022-00025 on the County Clerk’s website, it shows 770 pages, but then IQS indicated that instrument is 7,000 pages (*see* Exhibit A). The purported “record of the public hearing” is still missing items, including but not limited to the official complete CUB application submitted to OCIDA and completed SEQRA forms for this Project. It also appears that at least hard copies of certain items were not available at either OCIDA’s office or the County Clerk’s office as the binder at the Clerk’s office had one or more tabs with nothing in the tab but a statement that the document is a link to a website that was not an OCIDA or County Clerk website. Even if the record were complete and available for inspection and copying on March 16, 2022 (which it was not), it is unreasonable for OCIDA to expect us and the public to review that many pages and make meaningful comments by March 30, 2022. Thus, OCIDA has failed to comply with the requirements of the EDPL, including but not limited to EDPL § 203.

Further, OCIDA has not made available the documents it stated were available in the public hearing notice dated February 2, 2022. Thus, again, OCIDA has failed to comply with the requirements of the EDPL, including but not limited to EDPL § 203.

OCIDA has still not responded to our Freedom of Information Law (“FOIL”) requests. We should not have to raise this issue again in this letter, but OCIDA continues to delay its response to our FOIL requests, as discussed in our prior letter dated March 2, 2022.

OCIDA has not made available the final signed resolution(s) regarding this project, including but not limited to the resolution(s) purportedly adopted on or about January 21, 2022, as to CUB’s project (including the Property) being a “retail” facility. Although, as we have repeatedly stated, this is a hospital or health-related facility that is not within OCIDA’s jurisdiction and authority.

We also note that some of the statements by OCIDA or CUB seem to indicate that they are now trying to characterize the taking of the Property here as something else or for a different public purpose. However, such efforts are clearly illusory and made in an illegal effort to try to get around the restrictions on OCIDA set forth in our prior comments.

All of this is more evidence of “bad faith” on the part of OCIDA and CUB and a lack of concern for providing us and the public a reasonable opportunity to comment on the records before OCIDA.

Based on the records that we have been able to inspect, it appears that the location of the CUB MOB/ASC is larger in size and in a different location than the MOB purportedly considered in the SEQRA review by the City of Utica Planning Board in 2018/2019. This raises issues that OCIDA is required to address under SEQRA. Is the proposed CUB MOB a different and additional MOB than what was considered by the Planning Board in 2018/2019? In other words, is the MOB in the location reviewed in 2018/2019 still proposed to be constructed, or is it just proposed to be in a different location? Either way OCIDA is required to do its own SEQRA review before proceeding with eminent domain for this MOB project. OCIDA is required under SEQRA to identify all relevant areas of environmental concern and take a “hard look” at those areas before it can move forward with the eminent domain proceeding. This MOB project must be studied in its current proposed size and location, and all environmental impacts associated with the MOB must be analyzed, including but not limited to, impacts on traffic, electrical, utilities, water and sewer use and the implications of being much closer to the proposed helicopter pad than the MOB proposal purportedly studied in 2018/2019 (*see* attached hereto **Exhibit B** showing the different locations).

The location of this MOB project in a different location with a larger size fronting on a different street with different entrance locations may have different and greater implications for vehicle and pedestrian traffic. There may be issues as to emergency vehicles and loading. The change in the location of the MOB and its entrances may have implications as to traffic interfering with what appears to be the proposed ambulance entrance to the hospital emergency room. The larger size may also have significant impacts as to electrical, utilities, water and sewer usage that has not been examined.

The location of this MOB directly across the street from the proposed ground-level helicopter pad raises concerns as to whether appropriate spacing will be provided around the helicopter pad, including but not limited to with regards to turbulence, exhaust and for approach and departure paths and sight lines. Notice to the Federal Aviation Administration (“FAA”) may be needed pursuant 14 CFR § 77.9 (*see e.g.* attached hereto as **Exhibit C** images from the documents referenced in Exhibit A). The medical imaging and similar equipment proposed to be used in the CUB Project in this location may have significant interference with helicopter instruments, compasses and navigational equipment. As indicated in documents purportedly part of the “record of the public hearing”, nearby electromagnetic devices, magnetic resonance imaging machines (“MRI”), large ventilator motors, elevator motors or other devices that consume large amounts of electricity may cause temporary aberrations and interference with such helicopter equipment. We are not aware of anything in the record showing where all such equipment will be located in the proposed CUB Project and analysis as to the impact of such equipment in such locations.

The proposed layout of the CUB Project that purportedly necessitates eminent domain therefore, for all the foregoing reasons, cannot be properly evaluated and commented on at this time, and again, alternative solutions should be considered.

Finally, the City of Utica Mayor in his letter to the Observer-Dispatch, dated March 22, 2022, stated that “there are ample opportunities at this location that can benefit everyone if the respective parties are willing to communicate and work together. The city has been willing to work with all parties for the betterment of our community. It is my hope other project stakeholders will do the same.” Bowers remains willing to discuss a solution here that does not involve eminent domain, and OCIDA should encourage CUB to do the same. We encourage OCIDA to read the Mayor’s letter, which is attached hereto as **Exhibit D**.

Thank you for your attention to this matter. Please include this letter and the enclosures in the Public Hearing record. If you have any questions or concerns, please do not hesitate to contact me.

Very truly yours,

BROWN DUKE & FOGEL, P.C.

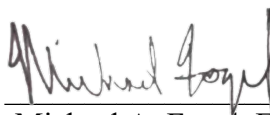
By:   
Michael A. Fogel, Esq.

cc: Paul J. Goldman, Esq.

Enclosures:

- Exhibit A:
  - Email by Patrick Donnelly, Esq., dated March 24, 2022
  - Email by Paul Goldman, Esq., dated March 16, 2022
  - Letter of Paul Goldman, Esq., dated March 16, 2022
- Exhibit B:
  - MOB locations
- Exhibit C:
  - Helicopter issues
- Exhibit D:
  - Letter to Observer-Dispatch, dated March 22, 2022, by City of Utica Mayor Palmieri



# **EXHIBIT A**

**From:** [Patrick Donnelly](mailto:Patrick.Donnelly@goldmanpllc.com)  
**To:** [PGoldman@goldmanpllc.com](mailto:PGoldman@goldmanpllc.com)  
**Cc:** [Shawna Papale](#); [Michael Fogel](#)  
**Subject:** RE: 411 Columbia Street, City of Utica, Oneida County, New York  
**Date:** Thursday, March 24, 2022 5:19:00 PM

---

Mr. Goldman:

First, in response to your email below, we were seeking to review the documents referenced in the hearing notice dated February 2, 2022, which states, "[Availability of Additional Information](#): More particular information concerning the Additional Project Land proposed to be acquired by the OCIDA pursuant to the EDPL, including legal descriptions and maps, and the Project are available for public inspection during normal business hours at OCIDA, 584 Phoenix Drive, Rome, New York 13441." It is apparent that was never made available to us and the public prior to the February 23, 2022 public hearing. It also appears that has still not been made available to us and the public.

Second, it is not clear whether the full record of the public hearing you reference in your email below (and your letter dated March 16, 2022) has been made available. In fact, it appears it has not been made available.

I went to the OCIDA office on March 17, 2022 and asked to inspect and copy the full record of the public hearing. It was not available. It appears that staff at OCIDA then rushed to put together a binder and a separate pile of papers that were not stapled or bound in any way. I asked if I could make copies and was told I couldn't. The staff also gave me a piece of paper with a link to a website of the Oneida County Clerk that was stated to have a binder of information. I tried the link on my cell phone and my laptop, but it didn't work. I eventually was able to find the purported documents through a search of the County Clerk's online land records using the instrument number stated on the piece of paper, and I started noticing discrepancies between that and what was provided to me for inspection (but not copying) at OCIDA's office.

I then went to the County Clerk's office that same day to see what was available there and what the options were for copying. After a large amount of explaining and discussing with different clerks, I was told the binder you provided to the County Clerk had not been scanned in yet and would cost about \$800 to \$1,000 for me to copy. (This itself was odd as I had already seen documents on the Clerk's website as stated above.) After more discussion with a couple clerks, I was allowed to look at the binder standing up at a table at the end of the clerk's desk. I immediately noticed discrepancies between what was presented to me at the County Clerk's from what was presented at OCIDA's office.

I then noticed earlier this week that OCIDA had posted online on its website in its minutes tab something called "Record of CUB Public Hearing and Comments". I immediately noticed discrepancies between that and what was presented to me at OCIDA's office and at the County Clerk's office. I then compared that to what was posted online on the County Clerk's website and noticed discrepancies, including that the record posted on OCIDA's website is 1165 pages long while the County Clerk's website shows 770 pages.

I then purchased and tried downloading the pdf on the County Clerk's website earlier this week, but the download did not work. I called the County Clerk's office and was eventually directed to the Clerk's vendor IQS who indicated the pdf was too large and that the IT person at IQS would email me the pdf in parts. IQS then also told me that the pdf they were emailing me was a total of 7,000 pages long.

Thus, I am left wondering what is the full record of the Public Hearing and whether it is the documents at OCIDA that are inconsistent with the documents OCIDA provided to the County Clerk or the 1165 pages, the 770 pages or the 7,000 pages.

It is ridiculous that OCIDA has this in such disarray and is giving us only until March 30, 2022 at 5 pm to comment. OCIDA must straighten this out and give us and the public a full and fair opportunity on proper notice to comment both orally and in writing.

Respectfully,

**Patrick D. Donnelly, Esq.**  
BROWN DUKE & FOGEL, P.C.  
120 Madison Street, AXA Tower 2, Suite 1620  
Syracuse, New York 13202  
Phone: (315) 399-4343, x206  
Fax: (315) 472-6215  
[pdonnelly@bdflegal.com](mailto:pdonnelly@bdflegal.com)  
<http://bdflegal.com/>

\*\*\*\*\*  
**Confidentiality Notice:** This e-mail transmission (including any attachments) is intended only for the use of the individual or entity to which it is addressed, and may contain information that is privileged, confidential, and exempt from disclosure under applicable law. If you are not the intended recipient, you are hereby notified that any disclosure, copying, distribution, or the taking of any action in reliance on the contents of this e-mail or any attachment is strictly prohibited. If you have received this transmission in error, please immediately notify the sender by return e-mail and delete all copies of this e-mail and any attachments.

---

**From:** Paul Goldman [<mailto:PGoldman@goldmanpllc.com>]  
**Sent:** Wednesday, March 16, 2022 4:41 PM  
**To:** Patrick Donnelly <[pdonnelly@bdflegal.com](mailto:pdonnelly@bdflegal.com)>  
**Cc:** Shawna Papale <[spapale@mvedge.org](mailto:spapale@mvedge.org)>; Jennifer Waters ([jwaters@mvedge.org](mailto:jwaters@mvedge.org)) <[jwaters@mvedge.org](mailto:jwaters@mvedge.org)>; Laura Cohen <[lcohen@mvedge.org](mailto:lcohen@mvedge.org)>; Bruce A. Smith <[bsmith@ccblaw.com](mailto:bsmith@ccblaw.com)>; Kevin Bernstein ([kbernstein@bsk.com](mailto:kbernstein@bsk.com)) <[kbernstein@bsk.com](mailto:kbernstein@bsk.com)>  
**Subject:** 411 Columbia Street, City of Utica, Oneida County, New York

Mr. Donnelly:

Please be advised that this firm represents the Oneida County IDA ("OCIDA") in connection with the above referenced Property. Pursuant to your request, I write to advise you that the record of the public hearing is now available for inspection at the offices of the OCIDA at 584 Phoenix Drive, Rome NY 13441. In addition, I am enclosing my letter of today's date addressed to the JP O'Brien Plumbing & Heating Supply Inc., Bowers Development, LLC and you and Mr. Fogel. Please advise me when you

wish to inspect the records and we will have that set up for you. In addition, the attached letter gives notice that you may provide additional comment on the documents on or before March 30, 2022 at 5.00. I am also providing a copy of this email to the Attorneys for CUB and MVHS and advising them that they have a similar right of inspection and comment on such documents.

If you have any questions please do not hesitate to call me.

**Paul J. Goldman, Esq.**

Goldman Attorneys PLLC

255 Washington Avenue Extension, Suite 108

Albany, New York 12205

Direct Dial: (518) 275-4411

Office: (518) 431-0941 Ext. 105 | Fax: (518) 694-4821 | Email: [pgoldman@goldmanpllc.com](mailto:pgoldman@goldmanpllc.com)

The information contained in this message contains information from Goldman Attorneys PLLC, which is confidential or privileged. The information is intended for the use of the individual or entity named above. If you are not the intended recipient, be aware that any disclosure, copying, distribution or use of the contents of this communication is prohibited. If you have received this e-mail message in error, please destroy this message and notify the sender by reply e-mail. Thank you.

Disclosure under IRS Circular 230: Unless expressly stated otherwise, nothing contained in this communication is intended or written to be used, nor may it be relied upon or used, (1) by any taxpayer for the purpose of avoiding penalties that may be imposed under the Internal Revenue Code, and/or (2) by any person to support the promotion or marketing of or to recommend any Federal tax transaction(s) or matter(s) addressed in this communication.

# GOLDMAN ATTORNEYS PLLC

*Attorney and Counselors at Law*

---

255 WASHINGTON AVENUE EXTENSION, SUITE 108  
ALBANY, NEW YORK 12205

TELEPHONE: (518) 431-0941  
FAX: (518) 694-4821

Paul J. Goldman  
[pgoldman@goldmanpllc.com](mailto:pgoldman@goldmanpllc.com)

March 16, 2022

## **CERTIFIED MAIL RETURN RECEIPT REQUESTED**

JP O'Brien Plumbing & Heating Supply, Inc.  
411 Columbia Street  
Utica, New York 13502

Bowers Development, LLC  
6308 Fly Road  
East Syracuse, New York 13057

Michael A. Fogel, Esq.  
Patrick Donnelly, Esq.  
Brown Duke & Fogel, P.C.  
120 Madison Street, Suite 1620  
Syracuse, New York 13202

Re: Eminent Domain Procedure Law §203 Public Hearing with respect to 411  
Columbia Street, City of Utica, Oneida County, New York a/k/a Section 318.41,  
Block 2, Lot 38 (the "Property")

Dear Sir or Madam:

Please be advised that this firm represents the Oneida County Industrial Development Agency ("OCIDA") in connection with its evaluation of the Need and Location for a Public Project consisting of a parking lot to be constructed on the Property pursuant to Article 2 of the Eminent Domain Procedure Law ("EDPL"). Per your request, the full record of the Public Hearing is available for inspection and copying at the office of the OCIDA located at c/o Mohawk Valley Edge, 584 Phoenix Drive, Rome, New York 13441. In addition, this record is also available for inspection and copying at the Oneida County Clerk's office located at 800 Park Avenue, Utica, New York 13501. If you wish to inspect the same at the offices of EDGE, please contact Ms. Jennifer Waters or Ms. Laura Cohen at (315) 338-0393.

**Further notice is hereby given that you and the public may comment on all or any portion of the attached documents by providing written comment to the OCIDA at c/o Mohawk Valley Edge, 584 Phoenix Drive, Rome, New York 13441 which comment must be submitted to the OCIDA on or before March 30, 2022 at 5.00 PM. Comments will be accepted by the OCIDA by hand delivery and/or email to [jwaters@mvedge.org](mailto:jwaters@mvedge.org). Finally, it is respectfully requested that comments not be repetitive with any comments previously made.**

**GOLDMAN ATTORNEYS PLLC**

*Attorney and Counselors at Law*

---

Very truly yours,

GOLDMAN ATTORNEYS PLLC



Paul J. Goldman

# **EXHIBIT B**

To accommodate the proposed MVHS IHC, the proposed Project will involve the acquisition of properties and modifications to existing public/private utility infrastructure. Descriptions of the Project elements are provided below.

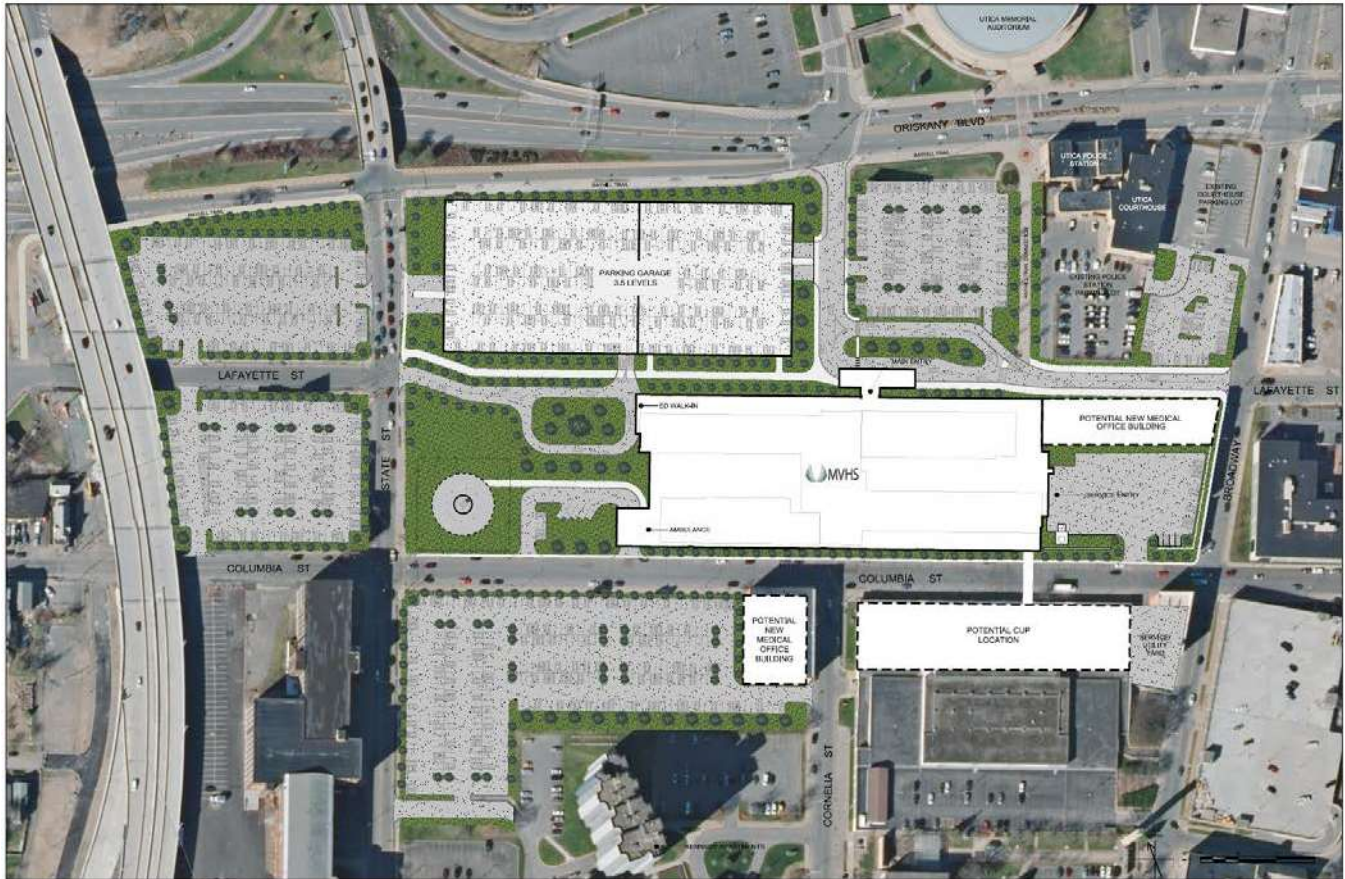

Figure 3. Integrated Health Campus (IHC)

## Facilities

### *Hospital Building*

The proposed 670,000± square foot (sf) hospital building will be constructed on parcels located west of Broadway and will extend through Cornelia Street onto parcels located east of State Street. The hospital building consists of a two-story podium and a seven-story bed tower.

Most services currently provided at the St. Luke's and SEMC campuses will be transitioned to the MVHS IHC including 373± inpatient beds (see below). MVHS plans to facilitate the adaptive reuse of the vacated space at the existing facilities (see Section 8 of the DEIS).

### *Central Utility Plant (CUP)*

From a facilities perspective, the consolidation of two aging facilities (100 and 60 years) will provide an opportunity for a more energy-efficient environment, with a state-of-the-art IHC that meets and exceeds current day best practices and building codes and promotes energy and water conservation and other sustainable measures that will reduce the overall amount of resources used by MVHS.







# **EXHIBIT C**

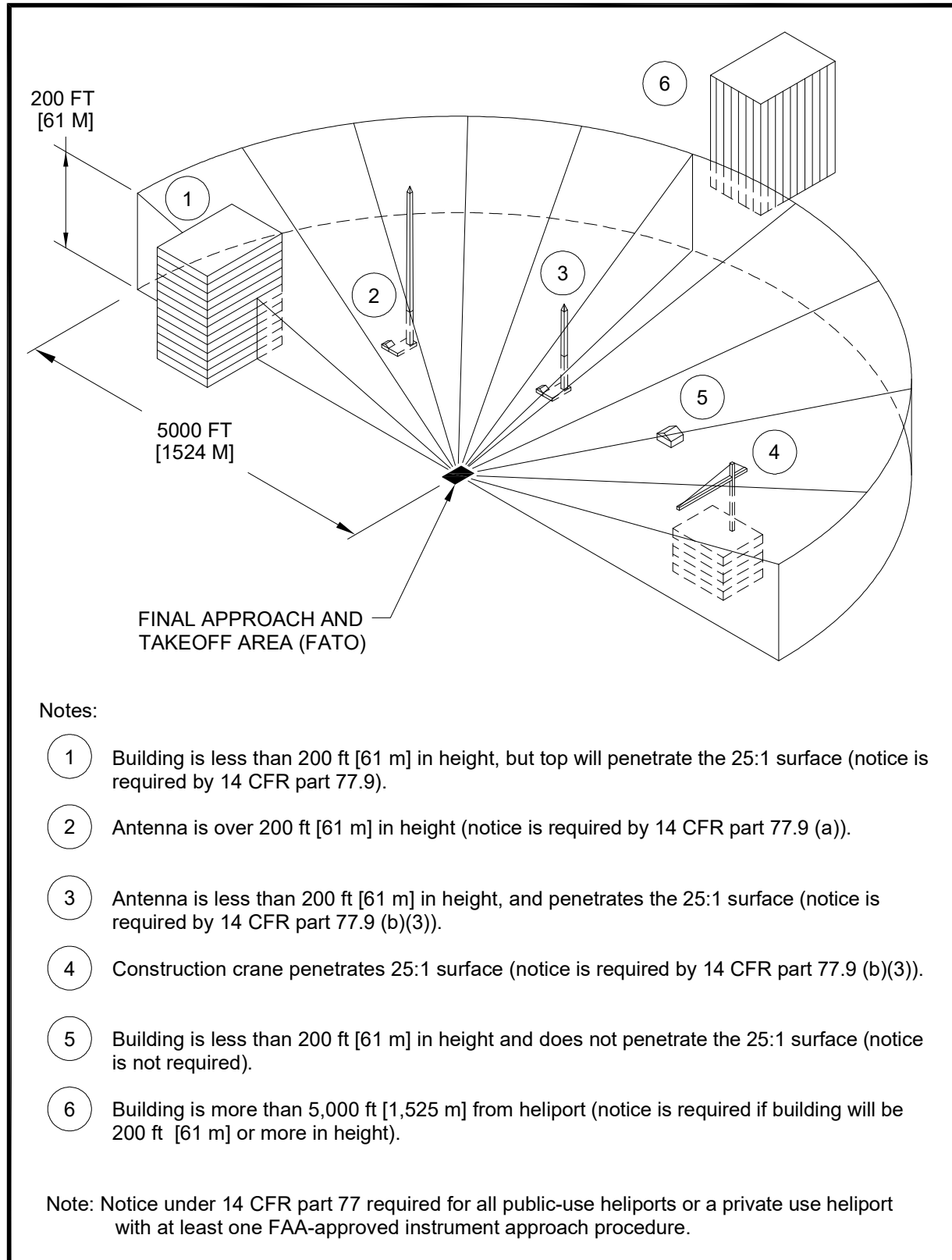

**Figure 1–4. Offsite Development Requiring Notice to the FAA**

**203. Prior permission required (PPR) facilities.** The standards in this AC are recommended for all heliports. As PPR heliports are never eligible for federal financial assistance, do not interpret any recommendation in this AC that is not required by federal law or regulation as mandatory for PPR heliports. Recommendations for PPR heliports are provided in recognition of the unique nature of facilities where the operator ensures pilots are thoroughly familiar with the heliport, its procedures, and any facility limitations.

**204. Access by individuals with disabilities.** Various laws require heliports operated by public entities and those receiving federal financial assistance to meet accessibility requirements. See paragraph 114.

**205. Heliport site selection.**

**a. Long term planning.** The FAA encourages public agencies and others planning to develop a general aviation heliport to consider the possible future need for instrument operations and expansion.

**b. Property requirements.** The property needed for a general aviation heliport depends upon the volume and types of users, size of helicopters, and the scope of amenities provided. Property needs for helicopter operators and for passenger amenities frequently exceed those for “airside” purposes.

**c. Turbulence.** Air flowing around and over buildings, stands of trees, terrain irregularities, etc. can create turbulence on ground-level and roof-top heliports that may affect helicopter operations. Where the FATO is located near the edge and top of a building or structure, or within the influence of turbulent wakes from other buildings or structures, assess the turbulence and airflow characteristics in the vicinity of, and across the surface of the FATO to determine if an air-gap between the roof, roof parapet or supporting structure, and/or some other turbulence mitigating design measure is necessary. FAA Technical Report FAA/RD-84/25, Evaluating Wind Flow around Buildings on Heliport Placement, addresses the wind’s effect on helicopter operations. Take the following actions in selecting a site to minimize the effects of turbulence.

**(1) Ground-level heliports.** Features such buildings, trees, and other large objects can cause air turbulence and affect helicopter operations from sites immediately adjacent to them. Therefore, locate the landing and takeoff area away from such objects in order to minimize air turbulence in the vicinity of the FATO and the approach/departure paths.

**(2) Elevated heliports.** Establishing a 6 foot (1.8 m) or more air gap on all sides above the level of the roof will generally minimize the turbulent effect of air flowing over the roof edge. Keep air gaps free at all times of objects that would obstruct the airflow. If it is not practical to include an air gap or some other turbulence mitigating design measure where there is turbulence, operational limitations may be necessary under certain wind conditions. See paragraph 101.

**d. Electromagnetic effects.** Nearby electromagnetic devices, such as a large ventilator motor, elevator motor or other devices that consume large amounts of electricity may cause temporary aberrations in the helicopter magnetic compass and interfere with other onboard navigational equipment.

**206. Basic layout.** A basic heliport consists of a TLOF contained within a FATO. A safety area surrounds the FATO. Table 2-1 shows how the standards for safety area width vary as a function of heliport markings. The relationship of the TLOF to the FATO and the safety area is shown in Figure 2–2. A FATO contains only one TLOF. Provide appropriate approach/departure airspace to allow safe approaches to and departures from landing sites. To the extent feasible, align the preferred approach/departure path with the predominant winds. See paragraph 210.

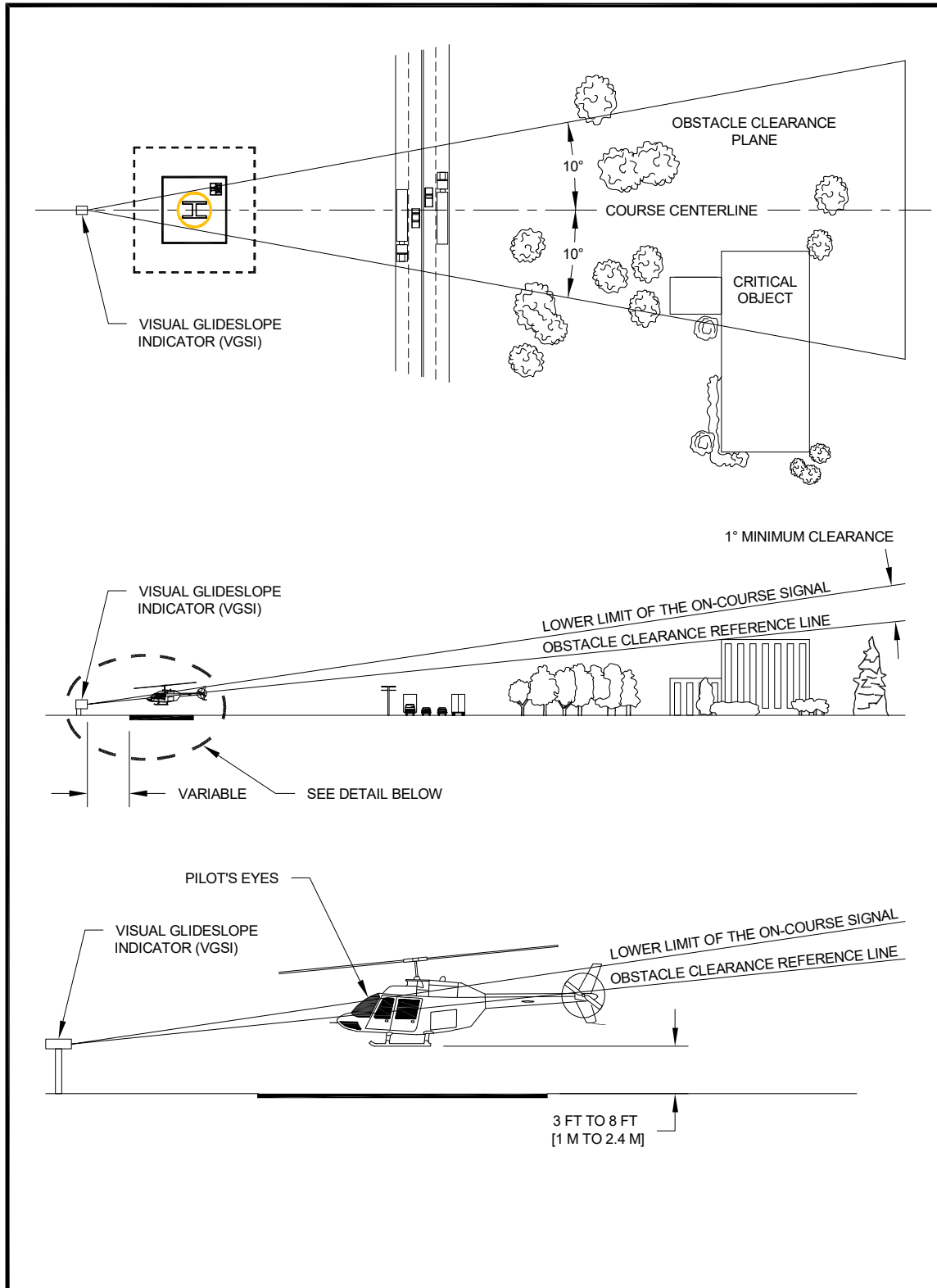
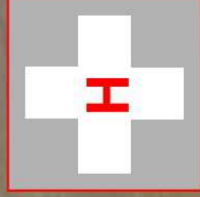

Figure 2-35. Visual Glideslope Indicator Siting and Clearance Criteria: General Aviation

# Planning for Growth

## Maximized Approach / Departure Path Fan

Large unobstructed areas create a much safer environment providing pilots multiple options



# Planning for Growth

## Reduced Approach / Departure Path Fan

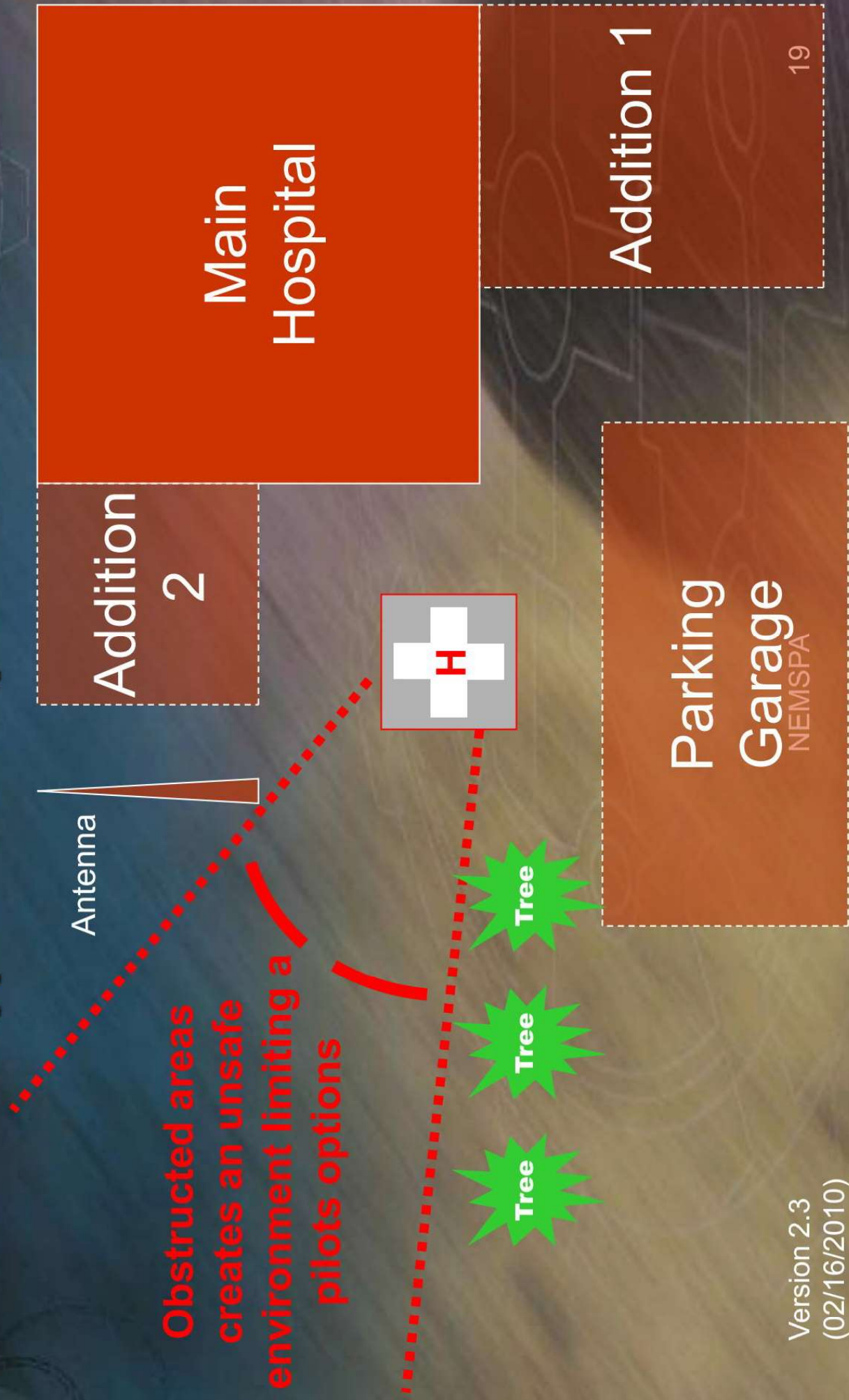



# Heliport Location

## • VENTILATION SYSTEMS

- Insure that you identify the location of all heating, ventilation and air conditioning (HVAC) systems prior to construction. Avoid locating a heliport near these. Exhaust fumes from a helicopter's engines can cause serious problems for a hospital and their staff if ingested into the hospital's ventilation system.
- Pay particular attention to which way the prevailing winds will carry any exhaust fumes from the proposed heliport site.



NEMSPA



# Heliport Location

Best  
Practices

- **Exhaust Fumes**

- **Rotor-Wash;** a column of accelerated downward moving air, that all helicopters produce at slow airspeeds during the approach and departure phase of flight can carry helicopter exhaust fumes several hundred feet below a rooftop heliport. This coupled with the influence that the architecture of a building may have on the air flow patterns must be closely scrutinized and studied when evaluating the potential impact a heliport may have on any hospital or any surrounding buildings and there fresh air intake system.

# **EXHIBIT D**

**OPINION** *This piece expresses the views of its author(s), separate from those of this publication.*

## Essay: City obligated to serve the interests of Utica taxpayers in hospital project

**Robert Palmieri** Guest essayist

Published 12:11 p.m. ET March 22, 2022

Since the inception of the downtown medical campus project, the City of Utica has been a steadfast partner.

The city dedicated substantive resources in support of the project; including over \$7 million of sewer/infrastructure improvements, over \$5 million in the reprogramming of its secured grant funding, conveyance of city-owned property to Mohawk Valley Health System (MVHS) and reoccurring loss of property taxes.

However, over the past several months, there have been several claims about the project that must be addressed.

A recent article claiming the County needed to bond for a larger parking garage because the city “rescinded” on a parking spot agreement for Kennedy Garage (Kennedy) is misleading. First and foremost, my obligation is to serve the interests of Utica taxpayers. Kennedy is a deteriorating garage which needs at least \$13 million in repairs. To put this in perspective, a 1% property tax increase yields approximately \$300,000 in revenue. This figure equates to a 43% tax increase for city residents.

As the city is experiencing transformational redevelopment, a private developer made a \$1.5 million offer to purchase Kennedy, which the city’s Urban Renewal Agency (URA) and Common Council approved. The \$13 million of repairs, coupled with the \$1.5 million purchase offer, yields a nearly \$15 million benefit to Utica taxpayers.

**Development:** Wynn Hospital parking garage to cost Oneida County an extra \$10 million

**Development:** Kennedy parking garage the latest approved Utica project for Bowers Development

Kennedy is an important piece in the development of the new downtown hospital, and the developers have repeatedly tried to meet with MVHS and the County to discuss the hospital’s parking needs. The developers have publicly stated their willingness to construct additional levels of parking onto Kennedy to accommodate the hospital. Unfortunately, MVHS and the County have refused to meet with the developer.

Furthermore, MVHS plans on leasing parking spaces in the city-owned Washington Street garage (Washington), which is across the street from Kennedy. The city’s plan is to utilize resources it will save from selling Kennedy and use it to fully repair Washington. If the city did not sell Kennedy; it would be an unfair burden to Utica taxpayers to invest over \$13 million to repair Kennedy and invest the necessary resources to repair Washington.

How much financial burden should Utica taxpayers incur for what will be a regional asset? Furthermore, why should Utica net a \$15 million loss because MVHS and the County refuse to answer the phone? Government should be efficient and strive to reduce its size, scope and costs as much as possible. It would have been fiscally irresponsible to not sell Kennedy, and my Administration, along with the Common Council, acted in the interest of Utica taxpayers.

Another misunderstood aspect of the medical campus project is the use of eminent domain of 411 Columbia Street for the construction of a medical office building. In speaking with senior MVHS officials last year, I encouraged them to secure all properties within the medical office building footprint through private transactions; by making purchase offers that reflected the value of its overall development plans.

Unfortunately, this did not transpire and a private developer purchased 411 Columbia Street to construct a medical office building with a group of local physicians. The Oneida County Industrial Development Agency is now considering taking the property (that is scheduled to be privately developed into a medical office building) through eminent domain, so a different private entity can construct its own medical office building.

It is an improper overreach of government power to take property from one private developer and give it to another for the same end use. Why should taxpayers bear the cost of eminent domain when the developer who already owns the property plans on constructing a medical office building on the same site?

**Development:** Public hearing held for Wynn Hospital eminent domain issue in Utica. What's next

Some have tried to compare the city's decision to pursue eminent domain of the former Northland Building to this case; however, the facts and circumstances are completely different. The city owned (through tax foreclosure) 80% of the Northland Building. By not fully owning the building, the city could not sell it and was forced to spend a significant amount of money to maintain it. In order to successfully market the building for economic development, the city had to take full ownership.

Should the city have continued to maintain a property it could never sell into perpetuity? How is that fiscally responsible or generate economic development? By pursuing eminent domain, URA was able to market the entire building and everyone had a fair opportunity to bid on it.

In light of the facts, the city's position on eminent domain is clear and consistent.

As for the broader medical campus project, there are ample opportunities that can benefit everyone if the respective parties are willing to communicate and work together. The city has been willing to work with all parties for the betterment of our community. It is my hope other project stakeholders will do the same.

*Robert Palmieri is the Mayor of Utica.*



March 30, 2022

Oneida County Industrial Development Agency  
Attn: Chairman  
584 Phoenix Drive  
Rome, New York 13441

**RE: Additional Comments Related to Eminent Domain  
411 Columbia Street, City of Utica, New York**

Dear Chairman:

Post review of some of the submitted public documentation related to this matter, I'd like to specifically point out the following:

- **Letter from Michael Kelberman (Central Utica Building) dated March 1, 2022:** In Mr. Kelberman's letter, he states that, "At the Public Hearing, CUB made clear that its MOB project is real and ready to go." However, at the conclusion of the letter (Financing Section), he states that "CUB cannot solicit and evaluate funding commitments until it knows that it has a project to finance – which will require the acquisition of the O'Brien Parcel." Based on the premise that his project is "ready to go" and he has hired multiple consultants / contractors, one can only assume that his last statement in the Financing Section is blatantly false and another fake argument to help CUB and OCIDA in their mission to take the property by eminent domain.
- **Letter from Charles Cronin dated February 28, 2022:** The inclusion of Mr. Cronin's letter should alarm the OCIDA. In our possession, we have an email from Mr. Bruce Smith (CUB's attorney) to members of CUB, which discusses the sale of the property to a real estate investment trust (REIT) upon completion. Since Mr. Cronin's firm helps facilitate the sale of completed development projects to REITs, it would bode the question, has anyone on the OCIDA researched if CUB's intention is to sell the MOB immediately upon completion? OCIDA and the County Executive will look pretty foolish to the entire community if CUB sells the property, immediately after they take it by eminent domain action.

We will continue to outright reject OCIDA's proposed use of eminent domain to take the property located at 411 Columbia Street, including using every possible legal means available.

Sincerely,

Bryan Bowers  
Managing Member  
Utica Med Building, LLC  
Bowers Development, LLC

**From:** [Jennifer Waters](#)  
**To:** [Laura Cohen](#)  
**Subject:** Fwd: Eminent domain 411 Colombia St.  
**Date:** Tuesday, March 29, 2022 6:41:04 PM

---

- Jennifer Waters via iPhone

---

**From:** Lily Werenczak <lilybrown0788@gmail.com>  
**Sent:** Tuesday, March 29, 2022 6:23:36 PM  
**To:** Shawna Papale <spapale@mvedge.org>; Info <info@mvedge.org>  
**Subject:** Eminent domain 411 Colombia St.

To whom it concerns, I'm writing this to express that I do not support the OCIDA to pursue 411 Columbia St. via eminent domain proceedings. The opportunity for MVHS to obtain this property fairly has come and gone. The promise of no burdens to the tax payers of Oneida County and Utica is a promise that did not hold water from the beginning. The morality of the proceedings of this project thus far have been questionable and moving ahead with eminent domain on such a property is all the same. It's immoral, unethical, and an overreach, especially utilizing taxpayer funds. A little competition at MVHS may in fact drive overinflated prices down, and that's nothing more than a GREAT thing. The current state of affairs is already a monopoly situation that will drive costs higher for our area. I absolutely disagree with eminent domain proceedings by OCIDA to attempt to acquire 411 Columbia St.

Lily M. Werenczak  
(315) 534-8097

CAUTION: This email originated from outside of the organization. Do not click links or open attachments unless you recognize the sender and know the content is safe.

**From:** [Shawna Papale](#)  
**To:** [Paul Goldman](#); [Jennifer Waters](#); [Laura Cohen](#); [Tim Fitzgerald](#); [Mark Kaucher](#)  
**Subject:** Fwd: No eminent domain  
**Date:** Tuesday, March 29, 2022 9:40:30 PM

---

Shawna Papale  
Sent from my iPhone

Begin forwarded message:

**From:** Richard Widdicombe <[richard.widdicombe@gmail.com](mailto:richard.widdicombe@gmail.com)>  
**Date:** March 29, 2022 at 9:39:10 PM EDT  
**To:** Shawna Papale <[spapale@mvedge.org](mailto:spapale@mvedge.org)>  
**Subject:** No eminent domain

Shawna

There should be no eminent domain regarding the medical office building.

Oneida County tax payers have suffered enough

[Richard.Widdicombe@gmail.com](mailto:Richard.Widdicombe@gmail.com)

Sent from Richard's iPhone  
315-749-8528

CAUTION: This email originated from outside of the organization. Do not click links or open attachments unless you recognize the sender and know the content is safe.



**From:** [Shawna Papale](#)  
**To:** [Paul Goldman](#); [Laura Cohen](#); [Jennifer Waters](#); [Tim Fitzgerald](#); [Mark Kaucher](#)  
**Subject:** Fwd: Eminent domain of 411 Columbia Street  
**Date:** Wednesday, March 30, 2022 12:45:27 PM

---

Shawna Papale  
Sent from my iPhone

Begin forwarded message:

**From:** Robert Lott <orwhat2014@gmail.com>  
**Date:** March 30, 2022 at 12:42:41 PM EDT  
**To:** Info <info@mvedge.org>  
**Subject:** Eminent domain of 411 Columbia Street

Strongly against eminent domain government coercion theft of property at 411 Columbia Street for the new Hospital Boondoggle. This whole process has been crammed down the throats of citizens at taxpayer expense. The taxpayer expense should have been at the expense of the medical industry and not the public. Typical government action of putting the cart before the horse. What's next that they haven't already conspired to do that hasn't been yet exposed. It's only obvious that the cost over-runs will continue because the government is ruining the economy. What about the federal bailout of New York and all the covid money that was supposed to benefit the medical industry. All these hospitals should have all the resources necessary to take care of the citizens.

Robert A.Lott  
8044 Wood Road  
Holland Patent, NY 13354

CAUTION: This email originated from outside of the organization. Do not click links or open attachments unless you recognize the sender and know the content is safe.

**From:** [Shawna Papale](#)  
**To:** [Paul Goldman](#); [Laura Cohen](#); [Jennifer Waters](#); [Tim Fitzgerald](#); [Mark Kaucher](#)  
**Subject:** Fwd: Eminent Domain for new hospital  
**Date:** Tuesday, March 29, 2022 7:57:03 PM

---

Shawna Papale  
Sent from my iPhone

Begin forwarded message:

**From:** rrobtombud <rrobtombud@aol.com>  
**Date:** March 29, 2022 at 7:52:47 PM EDT  
**To:** Shawna Papale <spapale@mvedge.org>  
**Subject: Eminent Domain for new hospital**

Dear Shawna,  
I saw on FB that Brett Truet was urging folks to write about the eminent domain and that the public comment period ends tomorrow.  
I want to say that I whole heartedly encourage the use of eminent domain for the new hospital and associated projects!  
(I know he wanted us to say the opposite- too bad!)  
I LOVE the new hospital and look forward to the rest of the corresponding construction projects.  
Keep on going!  
Robert Sullivan  
Utica

[Sent from the all new AOL app for iOS](#)

CAUTION: This email originated from outside of the organization. Do not click links or open attachments unless you recognize the sender and know the content is safe.



**Brett Truett** ▶ #NoHospitalDowntown

March 29 at 5:38 PM · 🌐



Please take a minute and send a quick email, see below...

Simply state you don't support eminent domain, especially when MVHS has hurt our tax base, and now wants to support rich doctors from paying costs they can VERY EASILY afford!!

Oppose the OCIDA (aka Oneida County) in their eminent domain action to seize 411 Columbia Street. Let's not allow Oneida County to use our tax dollars to fund a rich group of cardiologists!

You must email Shawna Papale (hey use both addresses!) no later than March 30th, that's tomorrow!

papale@mvedge.org

info@mvedge.org

This is YOUR public comment period and it ends on March 30th, tomorrow!!

Please know, OCIDA is planning a public meeting to discuss this on April 7th. The more emails they receive in opposition, the better!

These cardiologists might be fantastic doctors, but why make residents of a poor city/area make them richer?

Plus allowing your government to use eminent domain to take property from one private developer, only to give it to another private developer, is FLAT OUT WRONG!!

Shawna Papale is anxiously waiting to hear from you!

papale@mvedge.org

info@mvedge.org

THANKS!!!

[Utica](#) [#ny](#) [#eminentdomain](#) [#wynn](#) [#hospital](#)

📌 Topics [#eminentdomain](#)

👍 6

4 Comments 5 Shares

# #NoHospitalDowntown

Topics #eminentdomain

6

4 Comments 5 Shares

 Like

 Comment

 Share

Top comments

Write a public comment...

**Della Cummings**

Those rich Cardiologist will not last long here when they see Darlene runs things like a three ring circus 🤡!! I had an opportunity to speak to nurses recently. They are not happy with a lot of things but can't say anything for fear of dismissal. It's terrible!!

Like Reply Share 1d

**John Calhoun**

I do not support eminent domain. Not in the least. It is nothing but wholesale legalized thievery incubated in the fever dream imaginations of crooks, hooligans, swindlers and numbskulls who wear worn out Robert Hall suits. OCIDA, in their lunatic zeal... [See more](#)

Like Reply Share 1d 

**Jack Tobin**

Bernie Romano Clark?

Like Reply Share 1d

**Della Cummings**

I sent an Email

Like Reply Share 1d

Write a comment...